

Thermo IEC

OPERATION MANUAL

OMFA078A
Revision 0

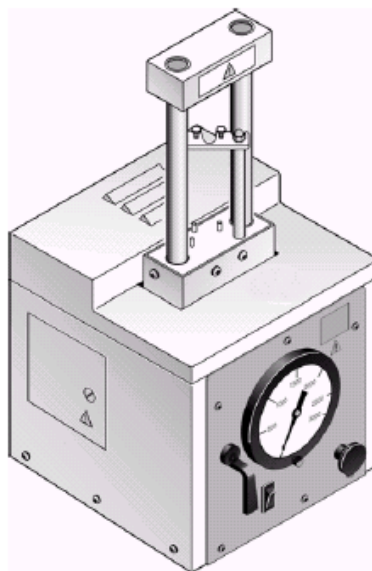

FRENCH® Press

Laboratory Press

Cat. No. FA-078A 120 VAC, 60 Hz

Cat. No. FA-078A-E 240 VAC, 50 Hz

Laboratory Press with Standard Pressure Cell

Cat. No. FA-080A 120 VAC, 60 Hz

Cat. No. FA-080A-E 240 VAC, 50 Hz

Laboratory Press with Mini Pressure Cell

Cat. No. FA-081A 120 VAC, 60 Hz

Cat. No. FA-081A-E 240 VAC, 50 Hz

NOTE

This operator's manual contains information, instructions and specifications for the FRENCH Press and the 20K and 40K FRENCH Pressure Cell that were believed accurate at the time this manual was written. However, as part of Thermo IEC's on-going program of product development, the specifications and operating instructions may be modified or changed from time to time. Thermo IEC reserves the right to change such operating instructions and specifications. Under no circumstances shall Thermo IEC be obligated to notify purchasers of any future changes in either this or any other instructions or specifications relating to Thermo IEC products, nor shall Thermo IEC be liable in any way for its failure to notify purchasers of such changes.

GENERAL SAFETY NOTES USED IN THIS MANUAL



This symbol alerts you to important information about using the instrument. Be sure to read and follow the associated instructions carefully.



This symbol alerts you to potential electrical hazards. Be sure that only qualified persons perform the related procedures.



This symbol alerts you to a crushing pinch point, which can cause personal injury.

WARNING

Only Thermo IEC's Pressure Cells should be used with the FRENCH Press. Thermo IEC Pressure Cells are designed for, and must only be used for, biological cell disruption. Use of the FRENCH Pressure Cells and Press for other uses may create hazardous conditions resulting in severe personal injury, death or property damage.

NOTE: The contact of the piston and the closure plug at high pressure can damage the piston, closure plug, cell body, or all three. Damage caused by piston/closure plug contact at high pressure is not covered by the product warranty.

PRECAUTION: During the assembly and fill process, do not allow the piston to pick-up granules (e.g., sand, glass, dirt, etc.). A contaminated piston will irreversibly damage the inside of the cell.

WARNING: FRENCH Press and FRENCH Pressure Cells are to be used only with samples of plant or animal cells. DO NOT put inappropriate materials (e.g., sand, glass, dirt, etc.) in the cell as this could result in an explosion, causing bodily injury.

WARRANTY

Thermo IEC wants you ("Customer") to be satisfied with the quality of your Thermo IEC FRENCH Press and related accessories (the "Products"). Thermo IEC warrants that the Products will operate substantially in conformance with our published specifications, when subjected to normal, proper and intended usage by properly trained personnel, for a period of ninety (90) days from the date of shipment from Thermo IEC (the "Warranty Period"). Thermo IEC agrees during the Warranty Period, provided it is promptly notified in writing upon the discovery of any defect and further provided that all costs of returning the defective Product to Thermo IEC are pre-paid by Customer, to repair or replace, at Thermo IEC's option, defective Products so as to cause the same to operate in substantial conformance with said specifications. Replacement parts may be new or refurbished, at the election of the Thermo IEC. All replaced parts shall become the property of Thermo IEC. Lubricants, o-rings, nylon balls and other expendable items are expressly excluded from the warranty. Thermo IEC's sole liability with respect to equipment, materials, parts or software furnished to Thermo IEC by third party suppliers shall be limited to the assignment by Thermo IEC to Customer of any such third party supplier's warranty, to the extent the same is assignable. In no event shall Thermo IEC have any obligation to make repairs, replacements or corrections required, in whole or in part, as the result of (i) normal wear and tear, (ii) accident, disaster or event of force majeure, (iii) misuse, fault or negligence of or by Customer, (iv) use of the Products in a manner for which they were not designed, (v) causes external to the Products such as, but not limited to, power failure or electrical power surges, (vi) improper storage of the Products or (vii) use of the Products in combination with equipment or software not supplied by Thermo IEC. If Thermo IEC determines that Products for which Customer has requested warranty services are not covered by the warranty hereunder, Customer shall pay or reimburse Thermo IEC for all costs of investigating and responding to such request at Thermo IEC's then prevailing time and material rates. If Thermo IEC provides repair services or replacement parts that are not covered by the warranty, Customer shall pay Thermo IEC therefore at Thermo IEC's then prevailing time and material rates. ANY INSTALLATION, MAINTENANCE, REPAIR, SERVICE, RELOCATION OR ALTERATION TO OR OF, OR OTHER TAMPERING WITH, THE PRODUCTS PERFORMED BY ANY PERSON OR ENTITY OTHER THAN THERMO IEC WITHOUT THERMO IEC'S PRIOR WRITTEN APPROVAL, OR ANY USE OF REPLACEMENT PARTS NOT SUPPLIED BY THERMO IEC, SHALL IMMEDIATELY VOID AND CANCEL ALL WARRANTIES WITH RESPECT TO THE AFFECTED PRODUCTS.

THE OBLIGATION CREATED BY THIS WARRANTY TO REPAIR OR REPLACE A DEFECTIVE PRODUCT SHALL BE THE SOLE REMEDY OF CUSTOMER IN THE EVENT OF A DEFECTIVE PRODUCT. EXCEPT AS EXPRESSLY PROVIDED IN THIS WARRANTY, THERMO IEC DISCLAIMS ALL WARRANTIES, WHETHER EXPRESS OR IMPLIED, ORAL OR WRITTEN, WITH RESPECT TO THE PRODUCT, INCLUDING WITHOUT LIMITATION ALL IMPLIED WARRANTIES OF MERCHANTABILITY OR FITNESS FOR ANY PARTICULAR PURPOSE. THERMO IEC DOES NOT WARRANT THAT THE PRODUCT IS ERROR-FREE OR WILL ACCOMPLISH ANY PARTICULAR RESULT.

NOTE: ALL CELL PARTS RETURNED TO THERMO IEC MUST BE AUTOCLAVED.

CONDITION OF RETURNED EQUIPMENT

Before returning equipment to Thermo IEC, you must contact Thermo IEC's or your dealer's service department and receive a return goods authorization (RGA). All returned units must be decontaminated, free of radioactivity, and free of hazardous and infectious materials. The RGA paperwork includes a certificate for you to sign indicating that you have performed these steps. Thermo IEC will not accept the shipment unless this signed certificate accompanies it. You must prepay transportation to the service depot.

IMPORTANT NOTE

If you receive any damaged items, forward an immediate request to the delivering carrier to perform an inspection and prepare a concealed damage report.

Do not dispose of any containers or packing material until the contents have been verified. Report to Thermo IEC the nature and extent of any damage to the instrument. Give the instrument's serial and catalog number. Action will be initiated to repair or replace damaged parts or instructions issued for the return of the instrument.

The responsibility of Thermo IEC ends with delivery to the first carrier. All claims for loss, damage or non-delivery must be made against the delivering carrier within ten (10) days of receipt of shipment.

TABLE OF CONTENTS

INTRODUCTION.....	1
A. WHY THE FRENCH PRESSURE CELL WORKS	1
B. THE FRENCH PRESSURE CELLS AND THEIR RAPID-FILL KITS	1
C. THE FRENCH PRESSURE CELL PRESS	3
D. PRINCIPLES OF OPERATION	4
II. THE FRENCH PRESSURE CELL PRESS.....	8
A. DESCRIPTION	8
B. ASSEMBLY.....	10
C. INSTALLATION	10
D. OPERATION.....	11
III. THE 40K MANUAL-FILL CELL.....	14
A. UNPACKING.....	14
B. ASSEMBLY.....	15
C. INSTALLATION	17
D. OPERATION.....	18
IV. THE 40K RAPID-FILL KIT.....	20
A. UNPACKING.....	20
B. ASSEMBLY.....	20
C. INSTALLATION	22
D. OPERATION.....	23
V. THE FRENCH PRESSURE MINI-CELL	25
A. UNPACKING.....	25
B. ASSEMBLY.....	26
C. INSTALLATION	27
D. OPERATION.....	27
VI. MAINTENANCE.....	29
A. THE FRENCH PRESSURE CELL PRESS.....	29
B. THE FRENCH PRESSURE CELLS.....	32
C. THE RAPID FILL KIT	35
VII. SAFEGUARDS	38
A. THE PRESS.....	38
B. THE CELLS	38
VIII. SPECIFICATIONS.....	40

INTRODUCTION

A. WHY THE FRENCH PRESSURE CELL WORKS

Internal FRENCH Pressure Cell pressure increases as the pressure developed by the Laboratory Press increases. The intracellular pressure increases as well. As the sample is dispensed through the sample outlet tube, the external pressure on the cells' walls drops rapidly toward atmospheric pressure. This pressure differential causes the cell wall membrane to burst, releasing the intra-cellular contents. The now-free cellular artifacts can be collected and separated as required.

Note that as the sample is dispensed from the FRENCH Pressure Cell, the internal pressure begins to drop. In order to ensure best disruption of cell walls, it is important to release the sample slowly (approximately 15 drops/minute rate). Slow release allows for a much slower decrease in the FRENCH Pressure Cell's internal pressure. At a slow sample release rate, the operator can better maintain the FRENCH Pressure Cell's internal pressure at the desired operating pressure.

It is also important that the FRENCH Pressure Cell piston NOT be allowed to bottom-out against the closure plug at the bottom of the cell when operating at high pressure. This may damage the piston, closure plug, and possibly the FRENCH Pressure Cell itself. Laboratory Press pressure should be reduced prior to the piston making contact with the closure plug; several millimeters distance protects the FRENCH Pressure Cell from damage and still allows for dispensing with minimum sample waste.

WARNING: ONLY THERMO IEC'S PRESSURE CELLS SHOULD BE USED WITH THE FRENCH PRESS. THERMO IEC'S PRESSURE CELLS ARE DESIGNED FOR, AND MUST ONLY BE USED FOR, BIOLOGICAL CELL DISRUPTION. USE OF THE FRENCH PRESSURE CELLS AND PRESS FOR OTHER USES MAY CREATE HAZARDOUS CONDITIONS RESULTING IN SEVERE PERSONAL INJURY, DEATH, OR PROPERTY DAMAGE.

B. THE FRENCH PRESSURE CELLS AND THEIR RAPID-FILL KITS

The FRENCH Pressure Cell is a dispersion unit for disintegrating chloroplast material, blood cells, unicellular organisms, homogenates of animal tissue, and other biological particles. Use of the pressure cell allows destruction of the cellular walls of a sample while leaving the cell nucleus undisturbed. FRENCH Pressure Cells are available in manual-fill and rapid-fill configurations.

Manual-Fill 40K Cell (FA-032)
Maximum Working Pressure = 40,000 psi
Cell Capacity = 35 ml

A loading stand is provided for filling the cell.
See Figures 1 and 2.

Manual-Fill Mini-Cell (FA-003)
Maximum Working Pressure = 20,000 psi
Maximum Compressive Force on piston = 2,200 lbs
Cell Capacity = 3.7 ml
See Figure 4. (Rapid-Fill Kit is not available.)

Rapid-Fill Kit (FA-021) for the FA-031 40K cell
See Figure 3.

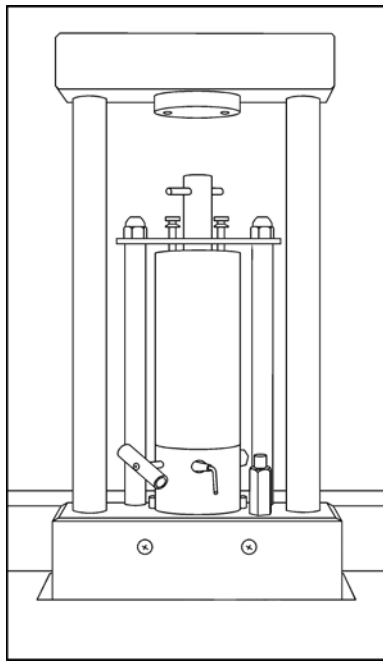

Figure 1
The 40K and 20K Manual-Fill Cell

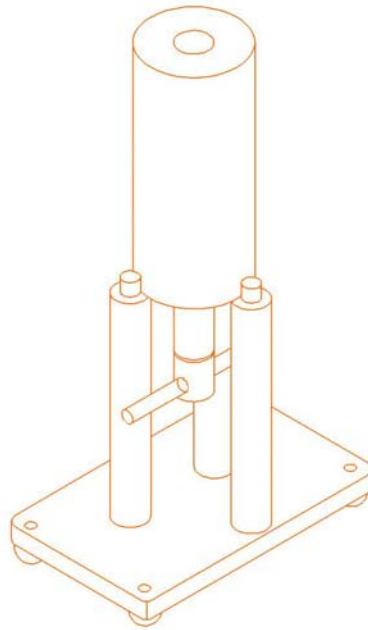

Figure 2
The 20K Cell in filling position

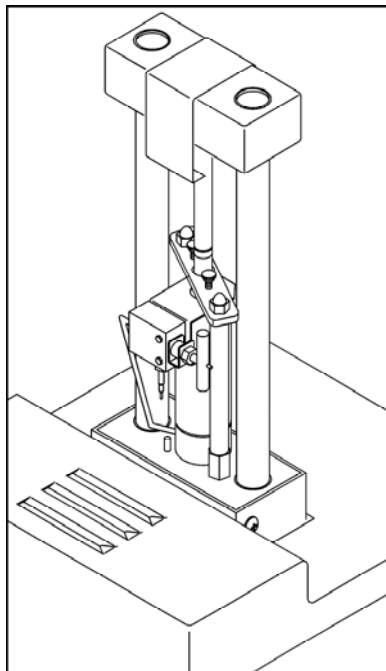

Figure 3
The 40K and discontinued 20K Cell with Rapid
Fill Kit

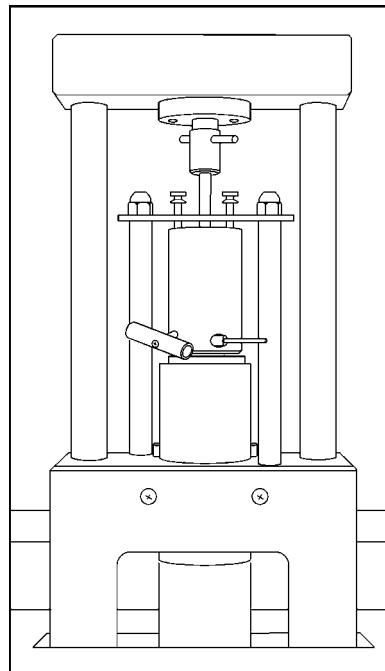

Figure 4
The Mini-Cell

C. THE FRENCH PRESSURE CELL PRESS

The FRENCH Pressure Cell Press is a hydraulic press which uses control valves and a motor-driven pump to vary hydraulic pressure generated by the press (see Figure 5).

The Press offers the advantages of dual-range, single-control pressure selection and fully-regulated working pressure through the entire operating stroke. These special features differentiate the motor-driven FRENCH Pressure Cell Press from manual presses.

The Press is designed for use with the FRENCH Pressure Cells manufactured by Thermo IEC to produce a selected pounds-per-square inch (psi) value inside a FRENCH Pressure Cell. It can accommodate both 1-in and 3/8-in diameter piston FRENCH Pressure Cells.

When the FRENCH Press and Pressure Cell are used, the following table shows the approximate factor difference between the press gauge pressure (psig) and the cell internal pressure at MED and HIGH range settings.

FRENCH Pressure Cell Piston Diameter	Internal Cell Pressure	
	MED RANGE (Gauge pressure x Factor)	HIGH RANGE (Gauge pressure x Factor)
1" (40K Cell)	psig x 3.1	psig x 16.0
3/8" (Mini-cell)	psig x 21.7	psig x 113.8 (Do NOT use the HIGH Range with the Mini-Cell.)

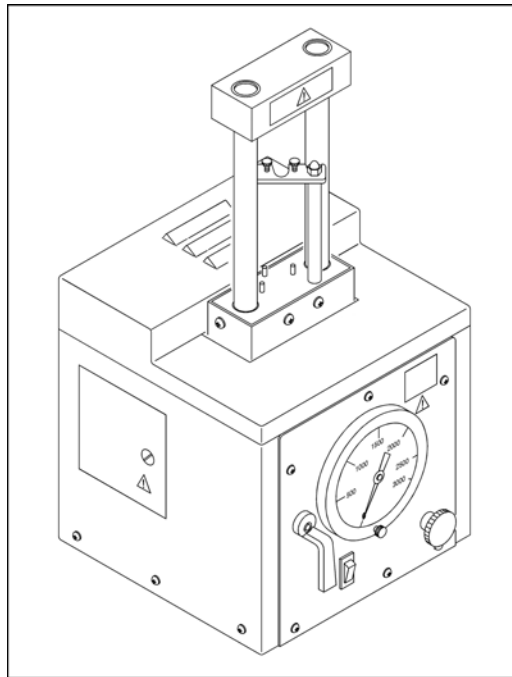

Figure 5
The FRENCH Pressure Cell Press

D. PRINCIPLES OF OPERATION

1. 40K Cell

In the following discussion, it is assumed that the FRENCH 40K Pressure Cell (1-in piston) is mounted properly in the cell holder, and the cell has been filled with a sample and cleared of air bubbles.

Before pressurizing the FRENCH Pressure Cell, determine the gauge pressure required to produce a known working pressure inside the cell. Note the pressure gauge on the FRENCH Pressure Cell pump indicates pressure on a hydraulic cylinder piston inside the press. The gauge pressure is not the actual working pressure in the FRENCH Pressure Cell. The pressure produced in the cell is proportional to the ratio of the areas (sq in) of the hydraulic cylinder piston in the press and the piston in the FRENCH Pressure Cell, as indicated by the following equation.

$$P_c = \frac{(Phcp)(Ahcp)}{Afc_p}$$

where:

- P_c = working pressure in the FRENCH Pressure Cell (lbs per sq in)
- $Phcp$ = pressure on the hydraulic cylinder piston
- $Ahcp$ = area (πr^2) of hydraulic cylinder piston
- Afc_p = area (πr^2) of FRENCH pressure cell piston

In the following example, assume that the pressure gauge reading ($Phcp$) is 1,250 psi with the RATIO SELECTOR lever set at HIGH. This pressure is applied to a hydraulic cylinder that has a diameter of 4 in ($Ahcp=12.56$ sq in), and a FRENCH Pressure Cell with a 1-in diameter ($Afc_p=0.785$ sq in). The working pressure in the FRENCH Pressure Cell is:

$$P_c = (1250) \frac{12.56}{0.785} = 20,000 \text{ psi}$$

When the RATIO SELECTOR lever is set to MED, hydraulic pressure is applied to both sides of the 4-in piston. The shaft that connects the piston to the press platen has a 1.75-in diameter; therefore, the effective area on top of the piston is reduced from 12.56 sq in to 10.16 sq in. Since equal pressure is applied to both the top of the piston (10.16 sq in) and the bottom of the piston (12.56 sq in), then the gauge pressure multiplied by 2.40 (12.56 sq in minus 10.16 sq in) equals compressive force in psi. Again, with the equation and values shown above but substituting 2.40 for $Ahcp$, the working pressure inside the FRENCH Pressure Cell would be 3,822 psi.

The calculations described on this page do not consider the weight of the platen or cell, or friction. The actual working pressure inside the FRENCH Pressure Cell would be somewhat lower than the calculated value.

For your convenience, the relationship between the gauge pressure and cell pressure is shown graphically in greater detail in Figures 6 and 7.

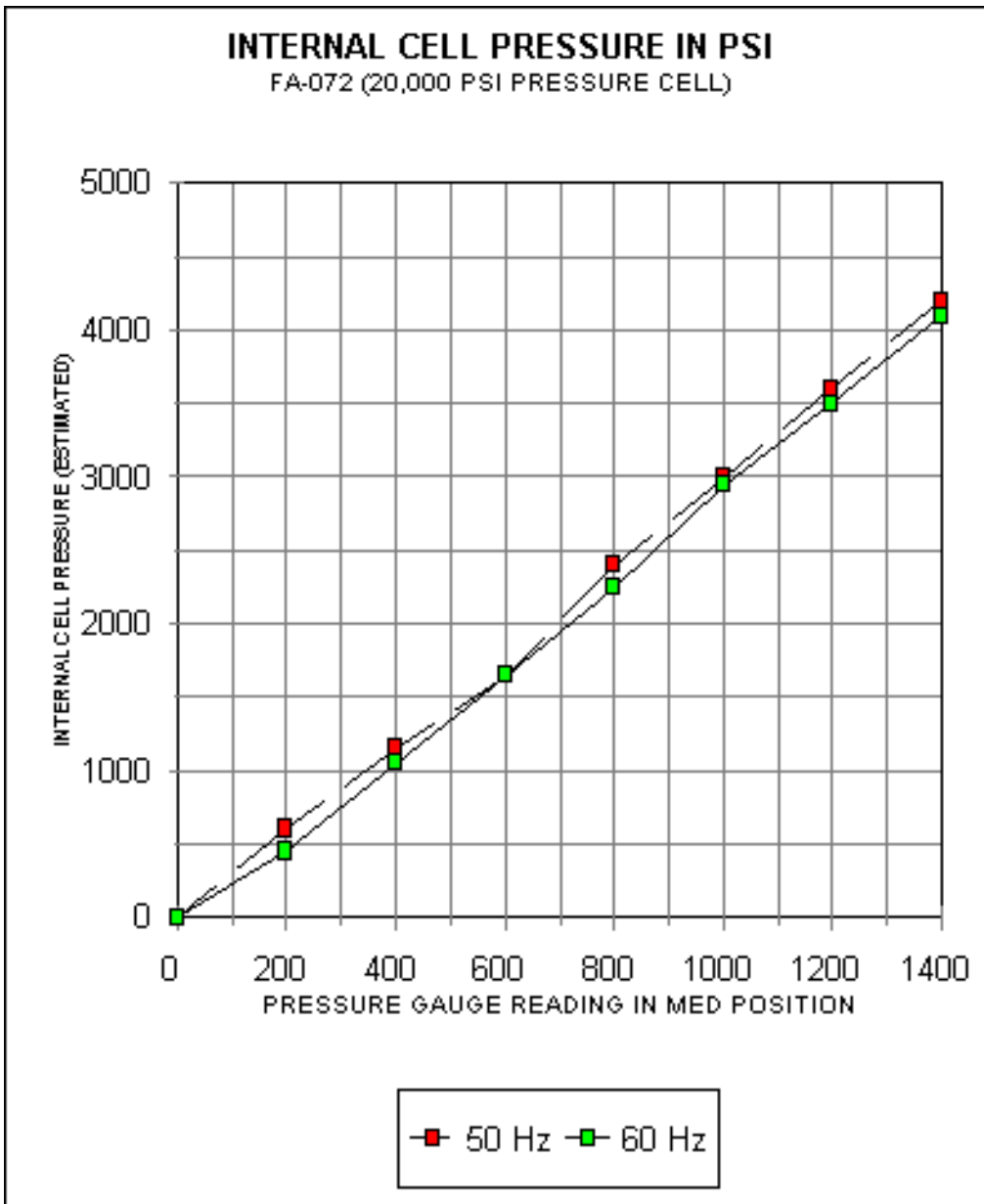

Figure 6
Internal Cell Pressure in psi, FA-032 (40,000 psi pressure cell)

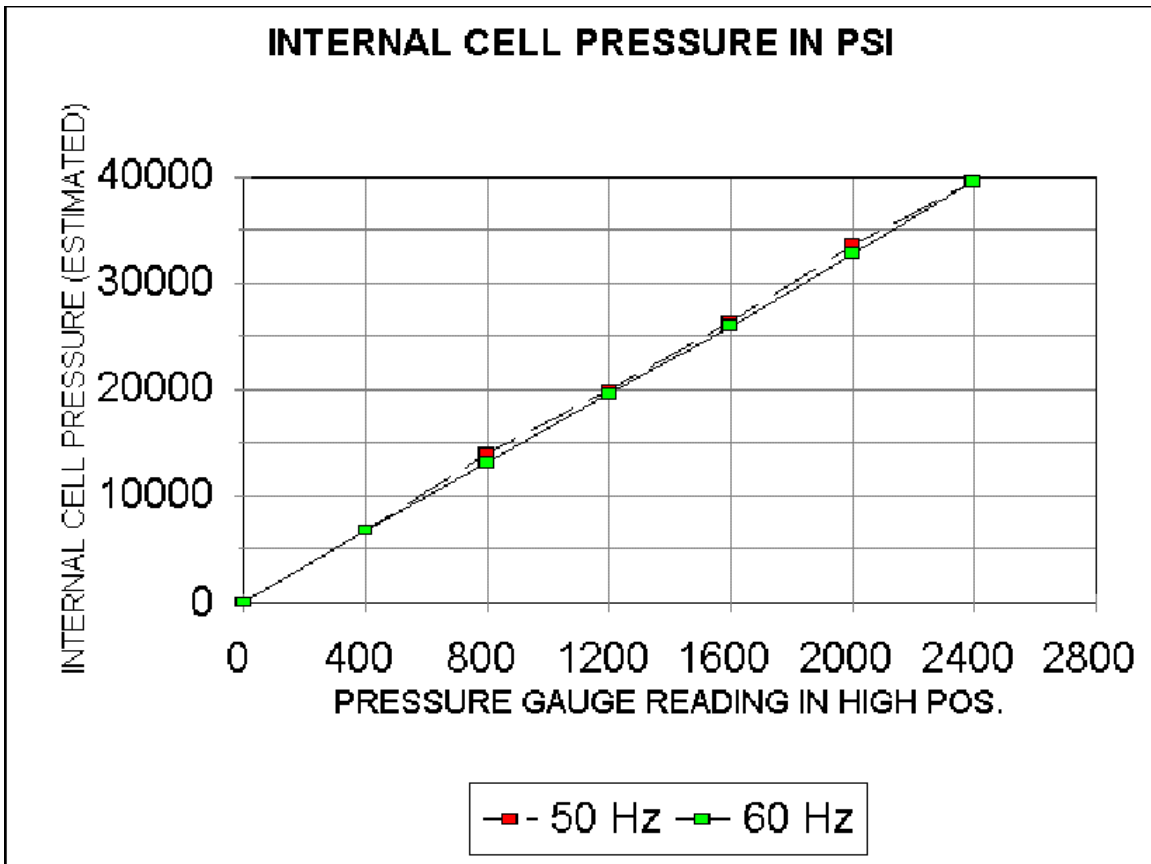

Figure 7
Internal Cell Pressure in psi, FA-032 (40,000 psi pressure cell)

2. 20K Mini-Cell specifications

In the following discussion, it is assumed that the FRENCH 20K Pressure Mini-Cell is mounted properly in the cell holder, and the cell has been filled with a sample and cleared of air bubbles.

- Do not exceed 20,000 psi pressure in the cell or damage occurs. This is a reading of 900 lbs on the gauge of the FRENCH Pressure Cell Press in MED ratio position.

When using the FRENCH Pressure Cell Press, refer to the graph (Figure 8) or to the table located on the front of the press to determine the desired gauge pressure setting necessary to achieve the required pressure in the cell.



WARNING: USE MED PRESSURE ONLY. THE MAXIMUM FORCE ON THE PISTON IS 2200 LBS (A READING OF 900 LBS ON THE FRENCH PRESS WITH THE PRESS IN MED POSITION). A SPACER (FA-010) IS REQUIRED FOR USE WITH THE FRENCH PRESSURE CELL PRESS. THE SPACER'S ALIGNING PINS CENTER THE CELL DIRECTLY ABOVE THE ACTUATING CYLINDER OF THE PRESS.

The cell clamp on the press secures the cell body to the lower platen. If no locking mechanism is available on the press that is being used take extreme care that the pressure is not released on the press while there is still hydraulic pressure in the cell. This can cause the cell body to ride up off the cell closure plug and either blow out the o-ring seal or bend that section of the closure plug that fits into the cell body.

If a manufacturer's press other than Thermo IEC is used, please note the gauge reading may indicate the pressure on the hydraulic ram inside the press. The working pressure inside the cell may be calculated using the following equation:

$$P_c = P_r \cdot \frac{\pi r^2}{0.1105}$$

where: P_c = working pressure inside the cell
 P_r = pressure on the hydraulic piston
 r = radius of the hydraulic piston
 0.1105 = the surface area of the mini-cell piston

Again, if another manufacturer's press is used, it is imperative that the platens be parallel and the cell be centered to prevent any side force on the piston. Forces other than a straight line through the cell could cause the piston to bend and the cell could be thrown from the press causing injury to the operator.

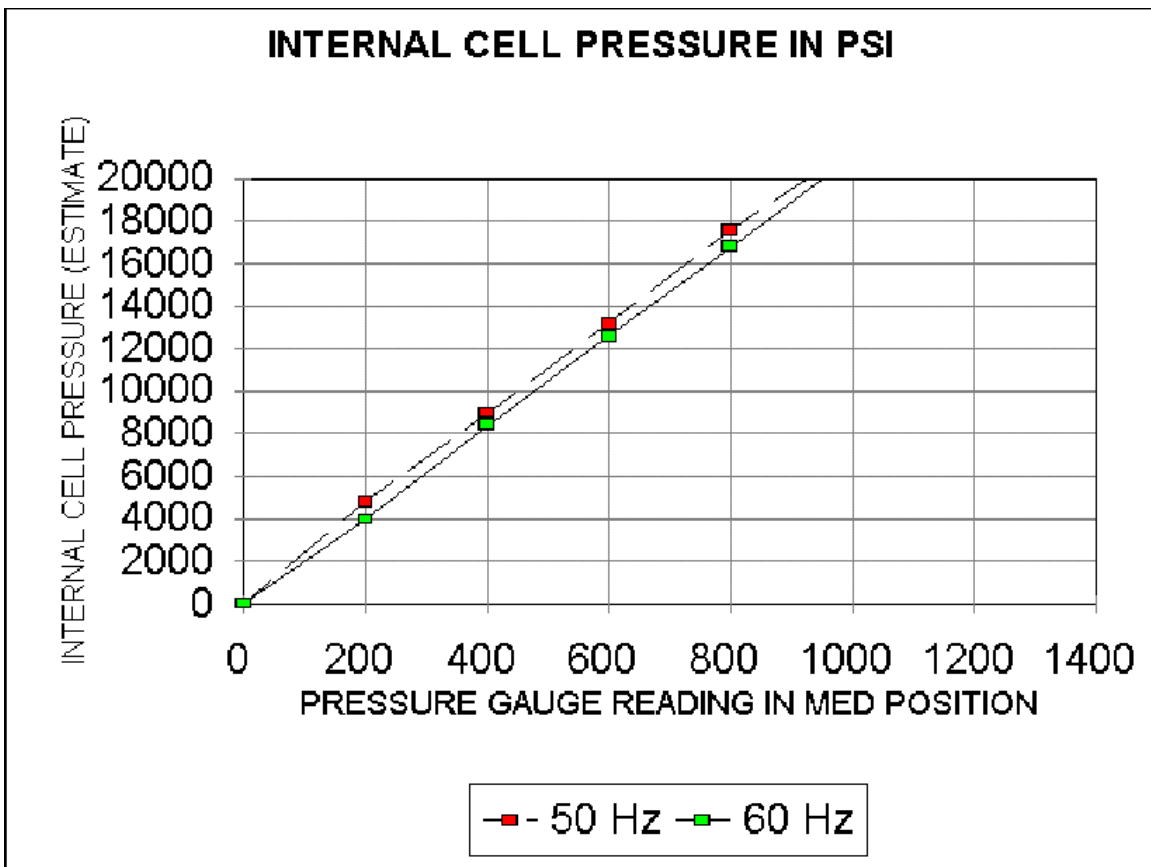

Figure 8
 Internal Cell Pressure in psi, FA-003 (Miniature Pressure Cell)

II. THE FRENCH PRESSURE CELL PRESS

A. DESCRIPTION

- | | | |
|-----|--|--|
| 1. | Side Panel Access Door | Opens to gain access to hydraulic fluid reservoir inside the press. |
| 2. | Ratio Selector Valve
A-5024 | MED or HIGH position is used in conjunction with PRESSURE INCREASE CONTROL to control pressure against lower platen (item 7). DOWN position permits lower platen to descend for pressure cell installation or removal. |
| 3. | PUMP Switch

E-0632 | Controls application of AC power to pump motor inside unit.
110V 10 AMP circuit breaker switch.
220V 6 AMP circuit breaker switch. |
| 4. | PRESSURE INCREASE control
A-5023 | Used in conjunction with RATIO SELECTOR control lever to regulate amount of pressure applied to lower platen (item 7). Clockwise rotation increases pressure, while counterclockwise rotation decreases pressure. |
| 5. | Pressure gauge, 0-3000 psi
A-5722 | Indicates pressure value at RATIO SELECTOR valve. The actual pressure value applied to lower platen depends upon the position of RATIO SELECTOR lever (HIGH, MED or DOWN). |
| 6. | Lower platen
PC-305 | Moves up or down to permit cell installation and subsequent pressurization to selected psi value. Three alignment pins on lower platen are used to position lower section of cell body in press. |
| 7. | Cell clamp
Support Rods (2 required)
PC-204
PC-418 Extensions | Provides support for the cell clamp. Remove rods, install rod extensions, replace rods for use with the 40K Cell. |
| 8. | Aligning Pins (3 required)
PC-303 | Centers the cell in the press. |
| 9. | Cell Clamp with thumb screws
PC-190 | Locks top of pressure cell in position to ensure proper cell alignment during pressurization. |
| 10. | Upper Platen
PC-306 | Provides a mechanical stop for the top of the pressure cell piston. Used also in conjunction with the spacer and piston retainer (not supplied) for positioning and housing these components when the rapid-fill pressure cells are used in the press. |
| 11. | Line cord
120V 335001-785
220V 335447-695
240V 335401-754 | Inputs AC power to the unit.
U.S. Plug
Continental Europe Plug
U.K. Plug |

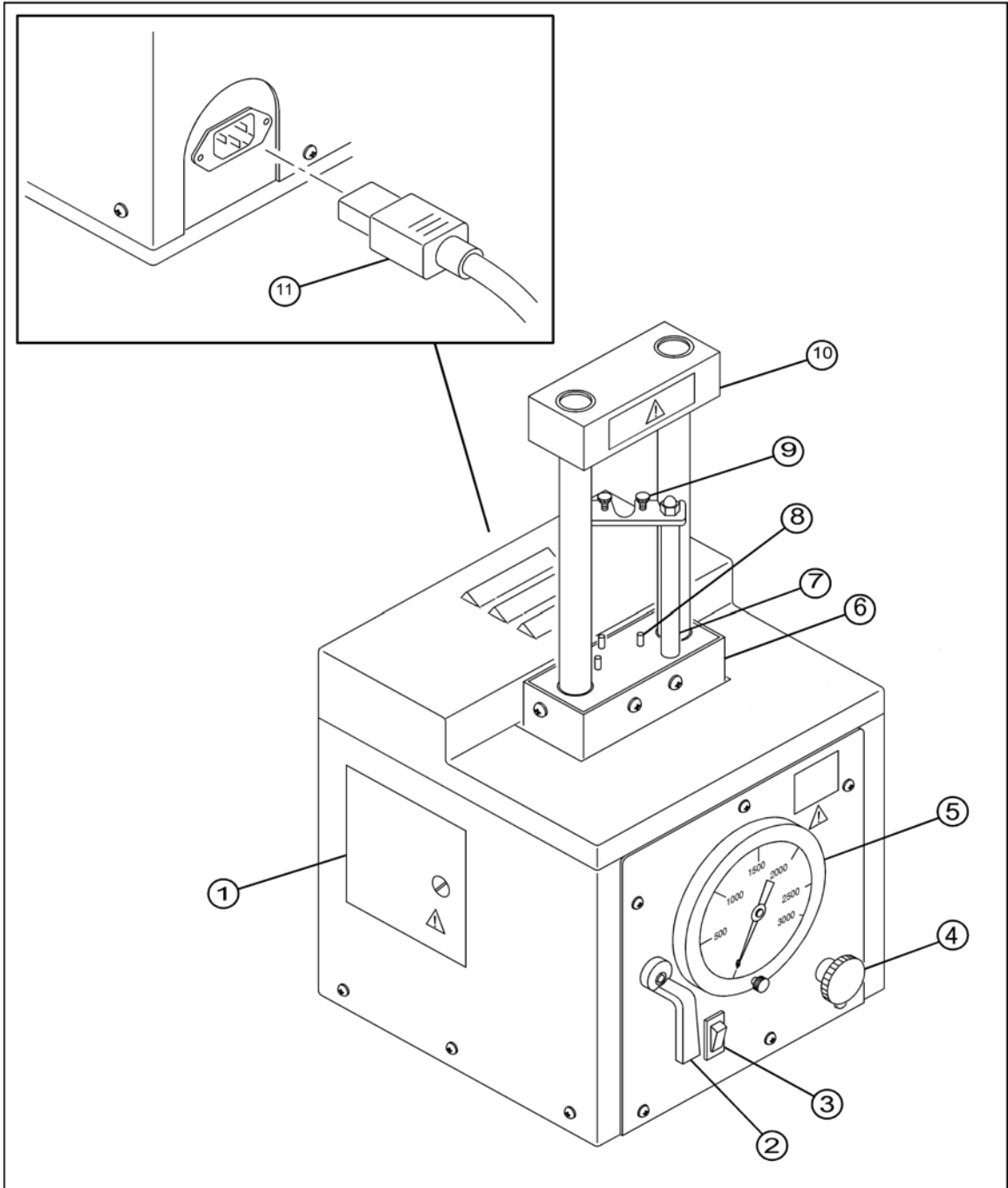

Figure 9
Controls and indicators of the FRENCH Pressure Cell Press

B. ASSEMBLY

The FRENCH Pressure Cell Press is completely assembled when shipped.

C. INSTALLATION

The three-prong power plug supplied grounds the press and polarizes the connection. Prior to connecting the FRENCH Pressure Cell Press to an AC source, ensure that the following requirements are met:

- a. Install only on a level surface capable of supporting the 240-lb press.
 - b. Verify that the 60 Hz power outlet can provide 15 amperes, 120V \pm 10% AC service; or when operating from 50 Hz, the power outlet must be capable of supplying 10 amperes at 220 or 240V \pm 10% AC.
 - c. Use only a three-hole, grounded power outlet.
 - d. Verify that the ground conductor is continuous to the main power panel which should be grounded directly to a metal water pipe or other earth ground.
 - e. Check the power outlet polarity and have the wiring changed, if required, to ensure proper polarity.
 - f. Ensure that no voltage gradient exists between the ground and neutral conductors.
1. Unpack and verify the contents with the parts list in this section.
 2. Position the press at a convenient location near a source of AC Power.
 3. Locate the access door on the left-hand side of the press; open the panel door.
 4. Remove the tape from the oil reservoir cap. The press is shipped with 450 SSU, Hydro 147, Viscosity –100. For refill, use a high-grade industrial oil such as Mobil DTE 26 or Shell Tellus 33.

PRECAUTION: For operation in ambient temperatures above 20°C (68°F), the hydraulic fluid supplied with the press (viscosity of 250-300 saybolt seconds universal (SSU) at 38°C (100°F) is satisfactory. If operation in colder temperatures is anticipated, the use of a lower viscosity hydraulic fluid, such as Mobil DTE 24 or Shell Tellus 25 (not supplied), will be necessary for viscosity of 150 SSU.

5. Check the fluid level in the reservoir using the dipstick indicator on the reservoir cap. Ensure that a sufficient amount of hydraulic fluid is in the reservoir (fluid level above mark on dipstick – see Figure 10).



WARNING: IF YOU OPERATE THE PRESS WITHOUT OIL, YOU WILL IRREVERSIBLY DAMAGE THE HYDRAULIC PUMP.

6. Replace the cap on the reservoir. Wipe any fluid spills from the exterior of the press cabinet. Close the access panel door.
7. Set PUMP switch on the front panel of the press to OFF. Connect the FRENCH Pressure Cell Press line cord to the power connector on the rear panel.

CAUTION: To eliminate the possibility of damage to the press pump motor, ensure that the AC line voltage and operating frequency is correct for the particular model of the FRENCH Pressure Cell Press. Refer to the model numbers.



WARNING: THE POWER OUTLET MUST BE GROUNDED PROPERLY AND POLARIZED. IMPROPER GROUNDING COULD RESULT IN ELECTRIC SHOCK.

8. Plug the line cord into the AC power outlet.
9. The FRENCH Pressure Cell Press is now ready for operation. Perform the procedures directed in OPERATION to verify operation of the unit.

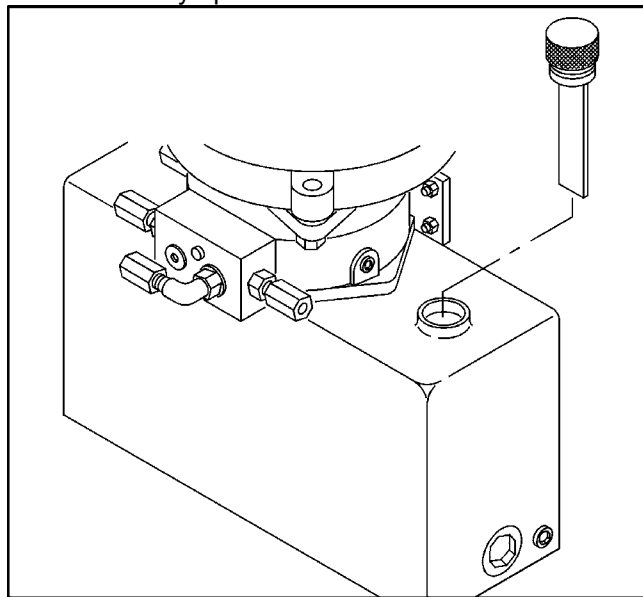

Figure 10
Hydraulic Fluid Reservoir
Access through side panel
access door

D. OPERATION

The following procedure assumes that the FRENCH Pressure Cell Press has been installed using the instruction given in INSTALLATION. It is also assumed that the FRENCH Pressure Cell is installed in the press as described in installation sections of this manual.

1. Set PUMP switch to OFF. Unplug the line cord.



CAUTION: Check the hydraulic fluid reservoir for the proper level before operating the press.

2. Open the side door and remove the reservoir cap. Check the level of hydraulic fluid in the reservoir and add hydraulic fluid of proper viscosity, if necessary. Replace the reservoir cap and close the side panel door (see Figure 10).

- Using the appropriate graph in Figures 6-8 or the table located on the front of the press, determine the gauge pressure required to produce a specific value of working pressure in the cell.



CAUTION: Do not operate the cell above its pressure rating.

- Plug in the line cord. Turn PRESSURE INCREASE control fully counterclockwise and set RATIO SELECTOR to DOWN.
- Set PUMP switch to ON and turn PRESSURE INCREASE clockwise until the gauge indicates the pressure value selected in step 3.

PRECAUTION: Be patient. It will take a few moments for the pump to fill and pressurize the internal hydraulics of the press.

- Set RATIO SELECTOR control lever to either MED or HIGH, the lever position again being determined by the pressure value selected in step 3.
- Check the cell alignment in the press as the lower platen rises. Ensure that the cell piston squarely strikes under the upper platen. If the pressure cell needs to be realigned, go to step 8.



WARNING: **ENSURE THAT THE T-HANDLE ON THE PRESSURE CELL PISTON IS ALIGNED PERPENDICULAR TO THE CELL CLAMP THUMBSCREWS. FAILURE TO PROPERLY ALIGN THE PISTON CAN CAUSE THE PISTON HANDLE AND THUMB SCREWS TO MEET, BENDING THE HANDLE AND POSSIBLY CAUSING THE THUMBSCREWS TO BREAK AND BECOME AIRBORNE. IF THE PRESSURE CELL NEEDS TO BE REALIGNED, GO TO STEP 8. IF NOT, PROCEED TO THE NEXT STEP. FAILURE TO FOLLOW THIS PROCEDURE WILL VOID THE WARRANTY.**

- Lower the platen by placing the three-position control lever to DOWN. Realign the cell in the press. See detailed mounting instructions in the pressure cell's INSTALLATION section if necessary.
- Recheck the psi reading on the pressure gauge to ensure that it indicates the predetermined pressure value. Open the flow valve on the cell slightly so liquid flows from the sample outlet tube at a rate of approximately 15 drops per minute. This is the maximum recommended flow rate.

NOTE: *The flow valve is extremely sensitive. To achieve the desired flow rate, gently finger tap the valve handle.*

SPECIAL PRECAUTION: In some applications, the FRENCH Pressure Cell and the suspension of biological material are cooled to sub-zero temperatures causing the formation of ice crystals. Ice crystals may remain unbroken even at high pressures, and when the flow valve is opened to release the pressure, the out-flow of the suspension may be blocked by these crystals. Sometimes, an uneven flow of the suspension is due to the presence of ice crystals in the flow stream. This may cause a sudden pressure drop. In such a situation you need to repeat this procedure.

In general, to get an even breakage, ensure:

- that you do not close the flow valve too tightly when filling the cell with the suspension,
- that you open the flow valve gently and cautiously so that the flow rate does not exceed approximately 15 drops per minute. The pressure tends to drop rather quickly toward the end of the run, you may want to close the flow valve slightly by turning it clockwise before opening it again.

Also, at the end of the run the flow stream may contain air bubbles causing the suspension to squirt into the collection tube. The sample may spill out and be lost. Be careful to position the sample outlet tube at a distance above the sample.

10. After the sample has been processed, lower the platen by placing the RATIO SELECTOR control lever to DOWN.

There will be some sample loss due to material left in the valve ports and drip tube. Do not try to squeeze out the last drop sample. You will damage the piston, closure plug and cell body.

11. Unless you are doing other tests, when the platen reaches its lowest position, reduce the system pressure to zero by turning the PRESSURE INCREASE control fully counterclockwise. Then set the pump switch to OFF.

NOTE: *For certain combinations of pressure and temperature, it is possible for the temperatures of the hydraulic fluid to increase to a point where its viscosity is lowered and the press is unable to maintain sufficient pressure for the period of time. Turning off the pump motor corrects this condition by allowing the hydraulic fluid to cool down and regain its viscosity. If the press blows a fuse, please verify that the pressure increase control is fully counterclockwise (zero pressure) before you turn the press back on.*

12. Remove the cell from the press when all the processing is complete. Clean and store the Pressure Cell using the instructions in the MAINTENANCE section.

13. Check the exterior of the press. Wipe any hydraulic fluid or sample spills from the press surface. See the MAINTENANCE section for specific cleaning procedures.

III. THE 40K MANUAL-FILL CELL

A. UNPACKING

Unpack the 40K cell. Check off the parts from the list below. If the equipment is received in damaged condition, forward an immediate request to the delivering carrier to perform an inspection and prepare a concealed-damage report. Do not destroy the container or packing material until the contents have been verified.

Concurrently, report to Thermo IEC the nature and extent of the damage incurred. Give the instrument's serial and part numbers, so that action may be initiated to repair or replace damaged parts or instructions issued for the return of the instrument. Do not return the damaged goods to Thermo IEC without first securing proper authorization from the company.

The responsibility of Thermo IEC ends with the delivery to the first carrier; all claims for loss, damage, or non-delivery must be made against the delivering carrier within ten days of the receipt of the shipment.

PACKING LIST FOR THE 40K CELL (FA-031)

DESCRIPTION	QUANTITY	PART NUMBER
Snap Ring Pliers	1	W-0106
Sample Outlet Tube	1	PC-113
Cell Body	1	PC-400
Closure Plug Assembly	1	PC-436
Piston Assembly	1	PC-172
Flow Valve Assembly	1	PC-435
-O-ring	Pkg of 10	FA-931
-Back-up ring	Pkg of 10	FA-932
Base with feet	1	PC-124
Post with H-0106 screw	3	PC-116
Envelope with		
-screw	1	H-0107
-washer	1	H-0177
Certification sheet	1	Y-0010
Operator's Manual	1	OMFA078A

B. ASSEMBLY

The following instructions are to install the 40K cell.

Use the exploded diagrams in Figures 11 and 12 to reference the parts of the cell. Please take careful note of the precautions as they can prevent future damage to the cell.

Only the PC-435 o-ring style flow valve assembly can be used to 40,000 psi

PRECAUTION: For the 40K, the valve should be finger tight. Excessive pressure to tighten the valve may distort the valve seat and cause leaking.

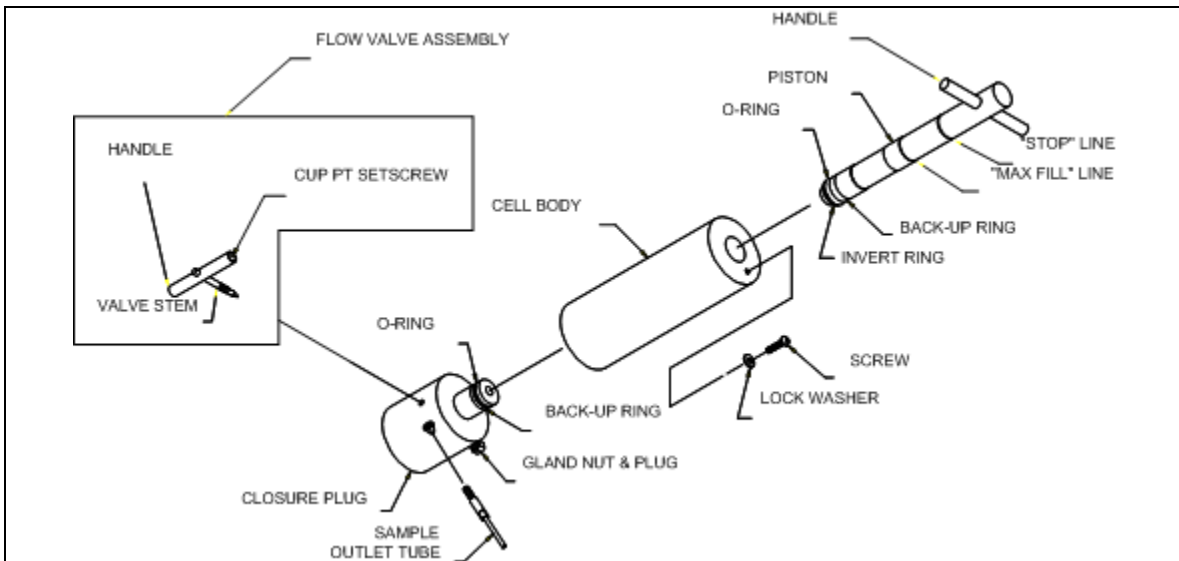

Figure 11
Exploded diagram of the 40K Manual-fill assembly

1. Verify the contents of the package with the parts list.

PRECAUTION: It is imperative to protect the piston from foreign matter at all times. Collected granules (e.g., sand, glass, dirt, etc.) will irreversibly damage the cell.

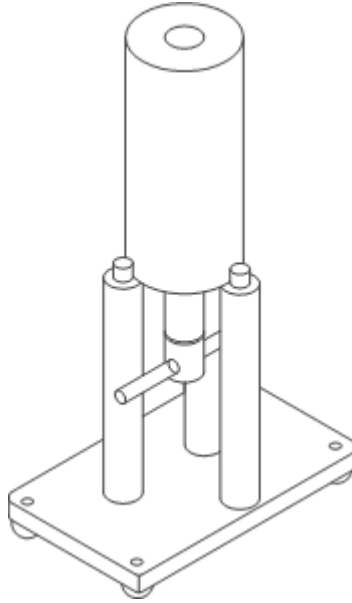

Figure 13
The 40K cell in filling position

2. Assemble the Cell Table Stand (see Figure 13).
3. Connect the Sample Outlet Tube to the closure plug.

NOTE: The tube may be bent to accommodate sample flow. Note that excessive bending may break the tube.

4. Simultaneously push and rotate the piston into the opening at the top of the cell. There may be some resistance to pushing in the piston.
5. Simultaneously push and rotate the closure plug into the opening at the bottom of the cell. Again, there may be some initial resistance to pushing in the plug.
6. Place the retaining screw and lockwasher in the small hole at the top of the cell body. Note the screw and lockwasher serve a function only when the Rapid-Fill configuration is used.
7. Connect the flow valve assembly to the closure plug.

PISTON FILL AND INSERTION LIMIT

The piston is marked to note the maximum it may be filled ("MAX FILL"), and to note the furthest it may be driven into the cell ("STOP").

Do not overfill the cell with material so that the piston cannot be installed to the "MAX FILL" mark.

NOTE: *The contact of the piston and the closure plug at high pressure can damage the piston, closure plug, cell body, or all three. Damage caused by piston/closure plug contact at high pressure is not covered by the instrument warranty.*

C. INSTALLATION

1. Unscrew and remove the cell clamp support rods from the lower platen on the press and install the two support rod extensions (PC-418) (from the FRENCH Press unit [FA-078A]). Replace the support rods by attaching them to the rod extensions (see Figure 14).
2. Place the cell on the lower platen between the aligning pins. Secure in place with the cell clamp. See Figure 14 for a description of the aligning pins and press cell clamp. Ensure that the piston handle is approximately perpendicular to the cell clamp so the T-handle cannot make contact with the cell clamp thumb screws.

D. OPERATION

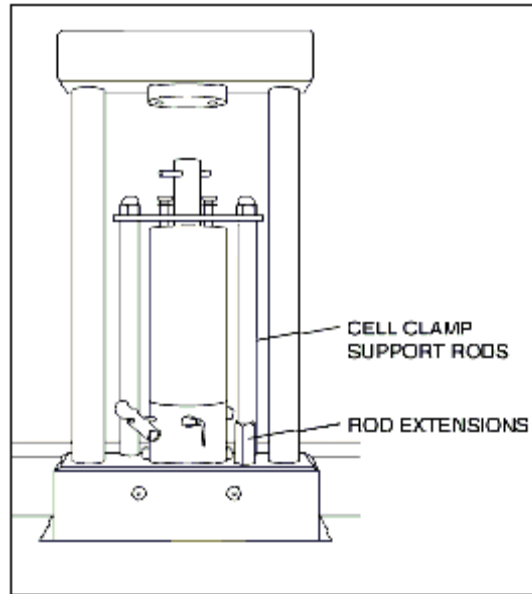

Figure 14
Rod extensions for the 40K Cell

1. Position the piston for the amount of sample you want to process. Do not, however, withdraw the piston further than the top MAX FILL. If you do, you could cause the piston and cell body to misalign and damage each other.

PRECAUTION: During the assembly and fill process, do not allow the piston to pick up granules (e.g., sand, glass, dirt, etc.). A contaminated piston will irreversibly damage the inside of the cell.

2. Set the cell on the filling stand and remove the closure plug (see Figure 13).
3. Fill the cell with the sample to a level that will cause a small amount of it to be forced through the sample outlet tube when the closure plug is installed.
4. Keep the flow valve open, insert the closure plug and push down until firmly seated on the body. This action forces out all the air from the cylinder and drains excess sample through the sample outlet tube.
5. Close the flow valve while the cell is still in the filling stand.



WARNING: DO NOT OVERTORQUE OR FORCIBLY TIGHTEN THE VALVE. OVERTIGHTENING MAY DAMAGE THE VALVE SEAT AND CAUSE LEAKING.

6. Hold the closure plug tightly against the body, invert the cell and place it in the press centering it carefully on the press platen.

PRECAUTION: The aligning pins, on the lower platen of the FRENCH Pressure Cell press, center the cell directly above the pressure actuating cylinder. Forces other than in a straight line through the cell cause scoring of the piston and possible damage to the inner wall of the cell body. Be sure the cell clamp of the laboratory press is properly and securely fastened to ensure that the cell cannot escape the press if improperly positioned or overpressurized.

7. Pressurize the cell to the desired working pressure. Ensure that the following maximum working pressure is not exceeded.



WARNING: **DO NOT OVERPRESSURIZE. BEFORE APPLYING PRESSURE TO THE CELL, DETERMINE THE GAUGE PRESSURE REQUIRED TO PRODUCE THE DESIRED PRESSURE IN THE CELL. IF THE MAXIMUM WORKING PRESSURE OF THE CELL IS EXCEEDED, THE SEALS AND/OR CELL ITSELF COULD RUPTURE CAUSING INJURY TO THE OPERATOR (SEE FIGURES 6 & 7).**

<u>PART NUMBER</u>	<u>MAXIMUM SAFE WORKING PRESSURE</u>	<u>MAXIMUM SAFE GAUGE READING IN "HIGH" RANGE</u>
FA-032 (40K)	40,000 psi	2,520 psi

NOTE: *The maximum working pressure is NOT related to the PRESSURE TESTED valve stamped on the cell body. The PRESSURE TESTED valve indicates the cell was proof-tested at the indicated value. The cell should never be pressurized above the maximum working pressure indicated above.*

8. After the desired pressure is built up in the cell, carefully open the flow valve so liquid flows from the sample outlet tube at approximately 15 drops per minute. During passage of the material through the valve, maintain pressure on the sample.

NOTE: *The flow valve is extremely sensitive. To get the desired flow rate, gently finger tap the valve handle. Also, the sample outlet tube may be bent to accommodate sample flow.*

PRECAUTION: There will be some sample loss due to material left in the valve ports and sample outlet tube. Do not try to squeeze out the last drop of sample. You will damage the piston, closure plug, and cell body.

IV. THE 40K RAPID-FILL KIT

A. UNPACKING

Unpack the rapid-fill kit. Check of the parts from the list.

If the equipment is received in damaged condition, forward in immediate request to the delivering carrier to perform an inspection and prepare a concealed-damage report. Do not destroy the container or packing material until the contents have been verified.

Concurrently, report to Thermo IEC the nature and extent of the damage incurred. Give the instrument's serial and part numbers, so that action may be initiated to repair or replace damaged parts or instructions issued for the return of the instrument. Do not return the damaged goods to Thermo IEC without first securing proper authorization from the company.

The responsibility of Thermo IEC ends with the delivery to the first carrier; all claims for loss, damage, or non-delivery must be made against the delivering carrier within ten days of the receipt of the shipment.

PACKING LIST FOR THE RAPID-FILL KIT (FA-021)

<u>Description</u>	<u>Quantity</u>	<u>Part No.</u>
Valve Mounting Bracket Assembly		
-valve mounting bracket	1	PC-404
-1/4-20 x 2 SS Hex Head Screw	2	H-0404
-retaining plate	1	PC-412
Liquid Inlet Connector Assembly		
-pickup tube	1	PC-408
-gland nut and sleeve	1	A-3338
Tube		
-tube (valve to closure plug)	1	PC-424
Silicone Rubber Tube 1/16"	3 ft	A-4172
Piston Retaining Bracket	1	PC-420
Liquid Inlet Valve	1	A-5022
Operator's Manual	1	OMFA0 78A

B. ASSEMBLY

This rapid-fill kit converts to a manual-fill (FA-032) pressure cell into a rapid-fill pressure cell. Use the exploded diagram to reference the parts (see Figure 15).

1. Assemble the valve mounting bracket onto the cell body. Secure the mounting bracket to the cell using the hole closest to the liquid inlet valve. Use the retaining screw and lockwasher already supplied with the manual-fill cell.

2. Loosely install the liquid inlet valve onto the valve mounting bracket using the two 1/2-20 hex head screws, lockwashers and the retaining plate. The valve needs to be loose to properly fit the tubing into the liquid inlet valve.
3. Install the closure plug in the bottom of the cell body.
4. Remove the high pressure plug (gland nut/plug) from the rear of the closure plug. Save it for use with the manual-fill configuration.
5. Assemble and install the tube between the liquid inlet valve connection furthest from the valve handle (backside) and the connection in the back of the closure plug. The shorter leg of the tubing installs in the liquid inlet valve. You may have to twist the cell body relative to the closure plug, and also raise or lower the liquid inlet valve to start the gland nut and sleeve into the closure plug or liquid inlet valve.

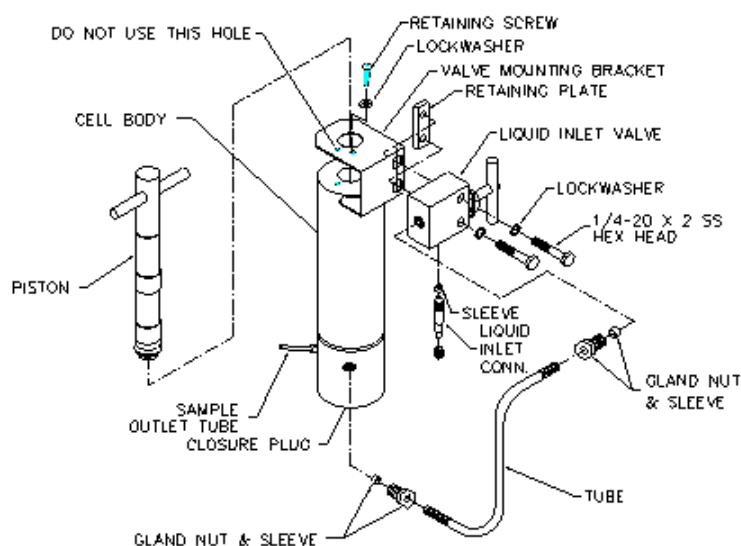

Figure 15

NOTE: *The sleeves on both ends of the connecting tube should be screwed on (left-hand thread) until approximately one thread is exposed. When the nut is tightened into the high pressure connection (25-30 ft.lbs./33.9-40.7nm), the end of the tube is forced into the seat, affecting the seal.*

6. After the tube assembly has been aligned and tightened, tighten the two 1/4-20 hex screws to secure the liquid inlet valve to the valve mounting bracket.
7. Install the liquid inlet connector assembly observing the conditions noted in step 6. Note the gland nut and sleeve is already installed in the valve. Remove them, assemble the liquid inlet connector and replace the assembly.
8. Install the remaining parts of the cell: piston, flow valve, sample outlet tube. See Figure 15 for a more detailed description of the manual-fill assembly.

C. INSTALLATION

1. Remove the cell clamp support rods from the lower platen on the press and install the two support rod extensions. Replace the support rods by attaching them to the rod extensions.
2. Place the cell on the lower platen between the aligning pins. Secure in place with the press cell clamp. See Figure 14 for a detailed description of the aligning pins and press cell clamp.
3. Open the flow valve on the cell.
4. Raise the piston of the cell into contact with the hardened spacer.
5. Slide the piston retaining bracket over the upper platen and piston T-handle. Turn the piston to lock the T-handle underneath the retaining bracket so that the handle cannot make contact with the cell clamp knurled screws during operation (see Figure 16).

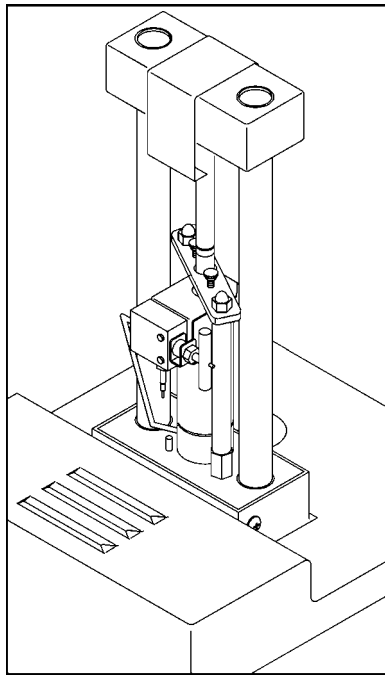

Figure 16
Assembling the piston retaining bracket.



WARNING: FAILURE TO PROPERLY ALIGN THE PISTON CAN CAUSE THE PISTON HANDLE AND THUMB SCREWS TO MEET, BENDING THE HANDLE AND POSSIBLY CAUSING THE THUMB SCREWS TO BREAK AND BECOME AIRBORNE. IF THE PRESSURE CELL NEEDS TO BE REALIGNED, GO TO STEP 2; IF NOT, GO TO NEXT STEP.
FAILURE TO FOLLOW THIS PROCEDURE WILL VOID THE WARRANTY.

D. OPERATION

1. Install the rapid-fill pressure cell in the press. See the 40K cell installation section in this chapter. Be sure the cell clamp on the laboratory press is properly fastened to ensure that the cell cannot escape the press if improperly positioned or over-pressurized.
2. Lower the platen by placing the three-position control lever to DOWN. Realign the cell in the press. See detailed mounting instructions in the pressure cell's INSTALLATION section if necessary.
3. Open both the flow valve on the cell and the liquid inlet valve.
4. Set RATIO SELECTOR valve on the press to DOWN. Set PUMP switch to ON and adjust PRESSURE INCREASE valve until the gauge indicates approximately 500 psi when the lower platen is at its lower limit. Set PUMP switch to OFF.
5. Connect a piece of tubing (1/8", 3/16" or 1/4" inside diameter) to the liquid inlet connection and immerse the free end in the sample.
6. Set RATIO SELECTOR valve to MED. Set PUMP switch to ON.
7. When the cell reaches its upper limit, close the flow valve on the cell and set RATIO SELECTOR valve to DOWN.



WARNING: DO NOT OVERTORQUE OR FORCIBLY TIGHTEN THE VALVE SHUT.

8. After approximately 10 ml of sample have been drawn into the cell, set PUMP switch to OFF.
9. To dispel air from the cell, close the liquid inlet valve, open the flow valve, and set RATIO SELECTOR to MED.
10. Place a flask under the sample outlet tube and set PUMP switch to ON.
11. When the cell reaches its upper limit, set PUMP switch to OFF.
12. Close the flow valve and open the liquid inlet valve. Air has now been dispelled from the cell.
13. Set the RATIO SELECTOR valve to DOWN. Set PUMP switch to ON.
14. After the cell has reached its lower limit, close the liquid inlet valve. The cell is now full of sample.
15. Dispelling of air is only necessary for initial charging of the cell.



WARNING: DO NOT OVERPRESSURIZE. BEFORE APPLYING PRESSURE TO THE CELL, DETERMINE THE GAUGE PRESSURE REQUIRED TO PRODUCE THE DESIRED PRESSURE IN THE CELL. IF THE MAXIMUM WORKING PRESSURE OF THE CELL IS EXCEEDED, THE SEALS AND/OR THE CELL ITSELF COULD RUPTURE CAUSING INJURY TO THE OPERATOR (SEE FIGURES 8 & 9).

16. Turn PRESSURE INCREASE valve until the gauge indicates the required hydraulic pressure to produce the desired working pressure in the cell. This pressure setting is determined from the table on the front of the press or from the appropriate graph.

For example, 20,000 psi in the cell requires an approximate hydraulic gauge pressure of 1,260 psi with the RATIO SELECTOR valve set to HIGH.

Be sure the following maximum working pressures are not exceeded as indicated in the table below.

<u>WORKING PRESSURE</u>	<u>MAXIMUM FORCE ON PISTON</u>	<u>MAXIMUM GAUGE READING "HIGH" RANGE</u>
20,000 psi	15,708 lbs	1,260 psi
40,000 psi	31,416 lbs	2,520 psi

Note the working pressure is NOT related to the PRESSURE TESTED value stamped on the cell body. The PRESSURE TESTED value indicates the cell was proof-tested at the indicated value. The cell should never be pressurized above the maximum working pressure indicated above.

17. Set RATIO SELECTOR valve to either MED or HIGH as required.
18. After the desired pressure is attained in the cell, carefully open the flow valve on the cell so that the liquid flows from the sample outlet tube at the rate of approximately 15 drops per minute.

NOTE: *The flow valve is extremely sensitive. To get the desired flow rate, gently finger tap the valve handle. The sample outlet tube may be bent to accommodate sample flow.*

19. When all liquid has been discharged from the cell, close the flow valve and open the liquid inlet valve.

PRECAUTION: Release cell pressure before you release pressure on the press. There will be some sample loss due to material left in the valve ports and drip tube. Do not try to squeeze out the last drop of sample. You will damage the piston, closure plug, and cell body.

WARNING: **FOLLOW THE VALVE DISASSEMBLY INSTRUCTIONS (PG. 43) CAREFULLY. THE VALVE STEM CAN BE DAMAGED WHEN THE PACKING NUT IS REMOVED. DAMAGE TO THE VALVE DURING DISASSEMBLY IS NOT COVERED UNDER WARRANTY.**

V. THE FRENCH PRESSURE MINI-CELL

A. UNPACKING

Unpack the FRENCH Pressure Mini-Cell. Check the parts from the list below. If the equipment is received in damaged condition, forward an immediate request to the delivering carrier to perform an inspection and prepare a concealed-damage report. Do not destroy the container or packing material until the contents have been verified.

Concurrently, report to Thermo IEC the nature and extent of the damage incurred. Give the instrument's serial and part numbers, so that action may be initiated to repair or replace damaged parts or instructions issued for the return of the instrument. Do not return the damaged goods to Thermo IEC without first securing proper authorization from the company.

The responsibility of Thermo IEC ends with the delivery to the first carrier; all claims for loss, damage, or non-delivery must be made against the delivering carrier within ten days of the receipt of the shipment.

PACKING LIST FOR THE MINI-CELL

<u>DESCRIPTION</u>	<u>QUANTITY</u>	<u>PART NO.</u>
Mini-Cell Body	1	PC-180
Flow Valve Assembly with Handle	1	PC-110
Piston Assembly	1	PC-182
Outlet Tube Assembly	1	PC-113
Closure Plug Assembly	1	PC-183
Back-up ring	10 in pkg	FA-935
O-ring	10 in pkg	FA-936
Certification sheet	1	Y-0010
Operator's Manual	1	OMFA078A

NOTE: *There is no Rapid-Fill Kit available for the Mini-Cell.*

B. ASSEMBLY

The following instructions are to assemble the min-cell. Use the exploded diagram (Figure 17) to reference the parts. Please take careful note of the precautions as they can prevent future damage to the cell.

1. Verify the contents of the package with the parts list.

PRECAUTION: It is imperative to protect the piston from foreign matter at all times. Collected granules (e.g., glass, sand, dirt, etc.) will irreversibly damage the inside of the cell.

2. Connect the Sample Outlet Tube to the cell.

NOTE: *The tube may be bent to accommodate sample flow. Beware that excessive bending may break the tube.*

3. Simultaneously push and rotate the piston into the opening at the top of the cell. There may be some resistance to pushing in the piston.
4. Simultaneously push and rotate the closure plug into the opening at the bottom of the cell. Again, there may be some initial resistance to pushing in the plug.
5. Connect the flow valve assembly to the cell.

PRECAUTION: It is imperative to protect the piston from foreign matter at all times. Collected granules (e.g., glass, sand, dirt, etc.) will irreversibly damage the inside of the cell.

PRECAUTION: The valve should be finger tight. Turn the valve until you feel a slight resistance, then turn it an extra 1/8 turn. Excessive pressure to tighten the valve can distort the shape of the nylon ball and may lead to leaking problems

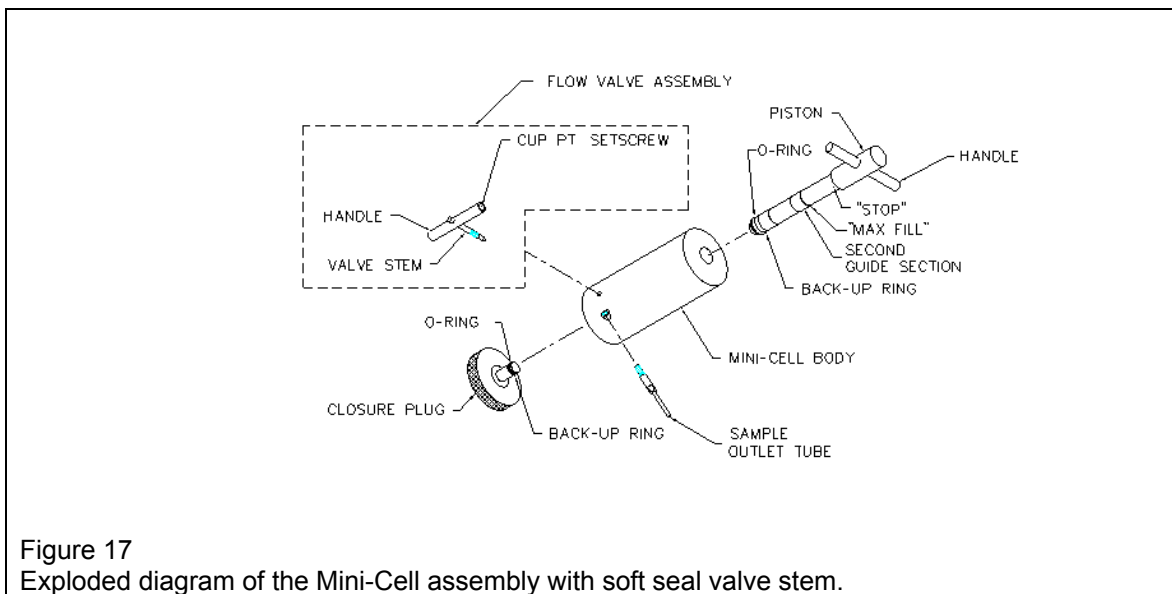

Figure 17
Exploded diagram of the Mini-Cell assembly with soft seal valve stem.

C. INSTALLATION

1. Place the mini-cell spacer between the aligning pins on the press platen.

PRECAUTION: It is imperative to protect the piston from foreign matter at all times. Collected granules (e.g., sand, glass, dirt, etc.) will irreversibly damage the inside of the cell.

2. Place the assembled mini-cell on the spacer using the pins on the spacer as a guide.
3. Secure the cell in place with the press cell clamp. See Figure 9 for a detailed description of the aligning pins and the press cell clamp. Be sure that the cell clamp on the laboratory press is properly fastened to ensure the cell cannot escape the press if improperly positioned or over-pressurized.



WARNING: **ALSO ENSURE THAT THE T-HANDLE ON THE PRESSURE CELL PISTON IS ALIGNED PERPENDICULAR TO THE CELL CLAMP THUMB SCREWS. FAILURE TO PROPERLY ALIGN THE PISTON CAN CAUSE THE PISTON HANDLE AND THUMB SCREWS TO MEET, BENDING THE HANDLE AND POSSIBLY CAUSING THE THUMB SCREWS TO BREAK AND BECOME AIRBORNE. IF THE PRESSURE CELL NEEDS TO BE REALIGNED, GO TO NEXT STEP. FAILURE TO FOLLOW THIS PROCEDURE WILL VOID THE WARRANTY.**

4. Lower the platen by placing the three-position control lever to DOWN. Realign the cell in the press. See detailed mounting instructions in the pressure cell's INSTALLATION section if necessary.

D. OPERATION

1. Invert the cell (closure plug up).
2. Remove the closure plug and withdraw the piston sufficiently to hold the sample. Do not position the piston past the maximum fill line.

PRECAUTION: During the assembly and fill process, do not allow the piston to pick-up granules (e.g., sand, glass, dirt, etc.). A contaminated piston will irreversibly damage the inside of the cell.

3. Pour the sample into the cell. The level of the sample should just cover the pressure flow valve hole. The level can be adjusted by repositioning the piston.
4. Keeping the piston from moving, open the flow valve and insert the closure plug, pushing it firmly against the cylinder bottom. This forces all of the air from the cylinder.
5. Close the flow valve while the cell is still in the filling position.



WARNING: **DO NOT OVERTORQUE OR FORCIBLY TIGHTEN THE VALVE. OVERTIGHTENING MAY DAMAGE THE VALVE SEAT AND CAUSE LEAKING.**

6. Holding the closure plug tightly against the cell body, invert the cell to its normal position and place in a press, carefully centering it on the press platen.



WARNING: THE AREA OF THE CELL PISTON IS 0.11 OF AN INCH; THEREFORE, ONLY 2,200 LBS OF COMPRESSIVE FORCE ON THE PISTON CREATES 20,000 PSI (MAXIMUM WORKING PRESSURE) IN THE CELL. THIS IS A READING OF 900 LBS ON THE GAUGE WITH THE PRESS IN MED POSITION. REFER TO THE GRAPH (FIGURE 10) FOR GAUGE READING WHEN USED WITH THE FRENCH PRESSURE PRESS.



WARNING: ALSO ENSURE THAT THE T-HANDLE ON THE PRESSURE CELL PISTON IS ALIGNED PERPENDICULAR TO THE CELL CLAMP THUMB SCREWS. FAILURE TO PROPERLY ALIGN THE PISTON CAN CAUSE THE PISTON HANDLE AND THUMB SCREWS TO MEET, BENDING THE HANDLE AND POSSIBLY CAUSING THE THUMB SCREWS TO BREAK AND BECOME AIRBORNE. IF THE PRESSURE CELL NEEDS TO BE REALIGNED, GO TO STEP 7; IF NOT, PROCEED TO THE NEXT STEP. FAILURE TO FOLLOW THIS PROCEDURE WILL VOID THE WARRANTY.

7. Lower the platen by placing the three-position control lever to DOWN. Realign the cell in the press. See detailed mounting instructions in the pressure cell's INSTALLATION section if necessary.
8. After the desired pressure is reached in the cell, open the flow valve slightly so the liquid flows from the sample outlet tube at the rate of approximately 15 drops per minute.

NOTE: *The flow valve is extremely sensitive. To get the proper flow rate, gently tap the valve. The sample outlet tube may be bent as desired to accommodate sample flow. However, the tube may break if consistently bent in different directions.*

9. The piston is marked to note the maximum it may be filled ("MAX FILL"), and to note the furthest it may be driven into the cell ("STOP").



WARNING: DO NOT OVERFILL THE CELL WITH MATERIAL SO THE PISTON CANNOT BE INSTALLED TO THE "MAX FILL" MARK.

NOTE: *The contact of the piston and the closure plug at high pressure can damage the piston, closure plug, cell body, or all three. Damage caused by piston/closure plug contact at high pressure is not covered by the instrument warranty.*

10. The liquid may be diluted and centrifuged to specifications.
11. After the required volume of liquid is obtained, and before releasing hydraulic press pressure, release pressure in the cell. Remove the cell from the press. There will be some sample loss due to the material left in the valve ports and drip tube. Do not try to squeeze out the last drop of sample. You will damage the piston, closure plug, or cell body.

NOTE: *The cell is rated at a maximum working pressure of 20,000 psi – DO NOT EXCEED!*

VI. MAINTENANCE

A. THE FRENCH PRESSURE CELL PRESS

This section contains fuse replacement, cleaning procedures and instructions for checking the hydraulic fluid level in the pump reservoir.

Operator maintenance is limited to these procedures. If your pump should require servicing, contact a Thermo IEC representative.

REPLACING THE FUSE

1. Set the PUMP switch to OFF. Unplug the line cord.
2. Unscrew the cap of the FUSE holder and remove the fuse.
3. Check for continuity across the fuse. If open, replace the fuse.
4. Screw on the FUSE holder cap. Restore the power to the unit.

CLEANING THE PRESS

1. Set the PUMP switch to OFF.
2. Wipe all sample or hydraulic fluid spills from the surface of the press.
3. Using a damp cloth, wipe clean the exterior of the unit. Use detergent solution, if necessary, but do NOT use a solvent.
4. If required, the face of the pressure gauge may be cleaned with a commercial glass cleaner.

CHECKING THE HYDRAULIC FLUID LEVEL

1. Open the side panel access door.
2. Remove the cap from the hydraulic fluid reservoir and check the fluid level on the dipstick. Add hydraulic fluid of proper viscosity to the reservoir, if necessary.
3. Replace the cap on the reservoir, then close the side panel access door. Wipe any hydraulic fluid spills from the exterior of the unit.

DRAINING/REPLACING HYDRAULIC FLUID

The hydraulic fluid used in the FRENCH Press must be of an appropriate viscosity for the temperature environment. If the press is to be used at the temperatures below 20°C, the standard hydraulic fluid shipped within the press should be changed to one of lower viscosity. To change the fluid, a hex-nut drain plug in the bottom corner of the hydraulic fluid reservoir is provided. Access to the drain plug is through a cut-away area beneath the left rear corner of the press assembly.

Temperature	Hydraulic Fluid
Above 20°C	Mobile DTE 26 Shell Tellus 33 HCP 32
Below 20°C	Mobile DTE 24 Shell Tellus 25 or 32 HCP 68

DRAINING PROCEDURE

1. Place the left side of the press slightly off the edge of the table to enable access to the reservoir drain plug through the cut-out area in the bottom left rear corner of the press base.
2. Place a drain pan beneath the reservoir drain plug.
3. Loosen and remove the hex-nut drain plug from the lower corner of the reservoir.
4. Allow the hydraulic fluid to drain.
5. Clean the drain plug, wrap with Teflon tape, replace, and tighten
6. Refill the reservoir.
7. To purge air from the hydraulic system, bring a cell up to pressure and then remove the pressure. Repeat this cycle two or three times.
8. Recheck the fluid level in the reservoir; add fluid as required to maintain the proper level as indicated on the reservoir dipstick.

REPLACEMENT PARTS FOR THE PRESS

The differences between the FA-078A, FA-078A-E1 and FA-078A-E2 FRENCH Pressure Cell Presses are the operating voltage and frequency. Be sure to specify the appropriate part number when ordering a replacement or fuse.

<u>DESCRIPTION</u>	<u>PART NO.</u>
Gauge, 0-3000 psi	A-5772
Oil, 1 gallon, 450 SSU, Viscosity –100	FA-930 (not for export)
Pressure Regulator (pressure increase valve)	A-5023
Pressure Pad (mount on upper platen)	PC-200
Selector Valve	A-5024
Fuse, 10 amp, 250V, Medium Time Lag (BUSSMANN ABC-10)	FA-927 (pkg of 10)
Fuse, 6 amp, 250V, Medium Time Lag (BUSSMANN ABC-6)	FA-928
Motor/pump/reservoir (115/230-240 VAC) for FA-078A	A-1029
Alignment Pins (for platen)	PC-303 (3 required)
Cell Clamp with two thumb screws	PC-190
Thumb Screws	PC-206
Cell Clamp Support Rods	PC-204
Support Rod Extensions	PC-418 (used with 20K and 40K cell bodies)
Line Cord (for use with 120V Lab Press)	335001-785
Line Cord (for use with 220V Lab Press)	335447-695
Line Cord (for use with 240V Lab Press)	335401-754
Spare Parts Kit 1 gallon hydraulic fluid (450SSU) (USA only) 10 fuses 3 alignment pins 2 thumb screws	FA-926
Operator's Manual	OMFA078A

B. THE FRENCH PRESSURE CELLS

DO NOT STORE THE PRESSURE CELLS ASSEMBLED.

Clean and dry the pressure cells thoroughly after each use. Components can be autoclaved if required. All metal parts are made of 400-series stainless steel (specially heat-treated) and are susceptible to surface corrosion if not properly cleaned and dried.

A light coating of mineral oil should be applied to all surfaces to prevent corrosion during periods of non-use. Coat internal surfaces with a light film of petroleum jelly before each use.

FLOW VALVES

The o-ring style flow valve assembly (PC-435) for up to 40,000 psi uses an o-ring valve stem. Excessive closing force will distort the valve seat in the closure plug and score the valve stem.

The flow valve stem (PC-161) for up to 20,000 psi uses a soft-sealed design, therefore do not over torque or forcibly tighten the valve shut. A little force can affect a good seal. If the seal is over tightened, the nylon ball may extrude into the valve seat. However, a small amount of extrusion does not affect the sealing ability of the valve.

When you cannot control the valve stem seal or the flow, replace the nylon ball as follows.

1. If the ball is still tight in the stem and cannot be removed with pliers, heat the ball over an open flame until the ball starts to melt; flip the old ball out.
2. After the stem has cooled, remove all traces of the old ball from the hole in the stem and press a new ball into place. Use a resilient surface to prevent distortion of the ball when pressing into the stem.
3. If the nylon ball becomes lodged in the valve seat due to excessive extrusion, leave the valve stem screwed loosely and pressurize the cell to dislodge the ball.

NOTE: Using the Cell/Press to create pressure for removing a stuck nylon ball is dangerous and must be performed carefully. The ball, once freed, will become a projectile and personal injury may result!

O-RINGS, RETAINING RINGS

Change the o-ring when the cell leaks or there is o-ring material in the sample. Cut off the old o-ring and stretch on the replacement.

When changing the retaining ring on the cell, use the retaining ring pliers. Other pliers or cutters will irreversibly damage the piston.

NOTE: *WHEN YOU REPLACE THE O-RING AND RETAINING RING, BE CAREFUL NOT TO DAMAGE THE PISTON TIP.*

REPLACEMENT PARTS FOR THE 40K CELL

<u>DESCRIPTION</u>	<u>QUANTITY</u>	<u>PART NO.</u>
Spare Parts Kit	1	FA-929
-retaining ring	10	
-o-ring	50	
-back-up ring	50	
-flow valve assembly	1	
-sample outlet tube	2	
-packing back-up ring	2	
-retaining ring pliers	1	
-gland nut	1	
-high pressure plug	1	
Piston Back-Up Rings	pkg of 5	FA-933
Piston O-Ring	1 pkg of 10	FA-931
Back-Up Rings	1 pkg of 10	FA-932
Retaining Ring	1 pkg of 5	FA-934
Snap Ring Pliers	1	W-0106
Piston Assembly	1	PC-172
-o-ring		
-back-up ring		
-retainer ring		
Closure Plug Assembly	1	PC-436
-o-ring		
-back-up ring		
-gland nut		
-high pressure plug		
Flow Valve Assembly	1	PC-435
Gland Nut with High Pressure Plug	1	PC-164
Sample Outlet Tube	1	PC-113
O-ring valve stem	1	PC-441
Cell Filling Stand	1	PC-122
Operator's Manual	1	OMFA078A

REPLACEMENT PARTS FOR THE MINI-CELL

<u>DESCRIPTION</u>	<u>QUANTITY</u>	<u>PART NO.</u>
Spare Parts Kit	1	FA-921
-o-rings	50	
-back-up rings	50	
-nylon balls	300	
-sample outlet tube	2	
-flow valve assembly	1	
Nylon Balls	pkg of 100	FA-924
	pkg of 1000	FA-925
O-rings	10	FA-936
Back-up rings	10	FA-935
Flow Valve Assembly with Handle	1	PC-161
Piston Assembly	1	PC-182
-o-ring		
-back-up ring		
Closure Plug Assembly	1	PC-183
-o-ring		
-back-up ring		
Sample Outlet Tube	1	PC-113
Cell Body	1	PC-180
Soft Seal Valve Stem	1	PC-126
Operator's Manual	1	OMFA078A

C. THE RAPID FILL KIT

DISASSEMBLING AND CLEANING THE RAPID-FILL KIT

1. Disconnect all tubing and remove the flow valve assembly from the Rapid-Fill Kit.

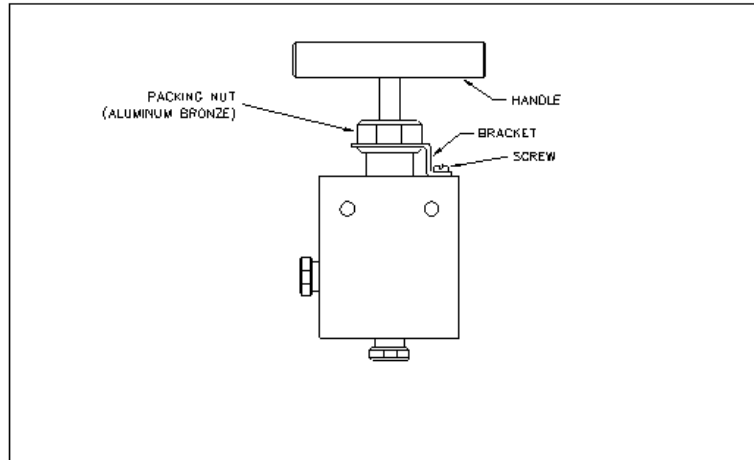

Figure 18

2. Remove screw from the bracket that encircles the large nut at the base of the flow valve handle (see figure 18).
3. Move the bracket so that it no longer encircles the nut.

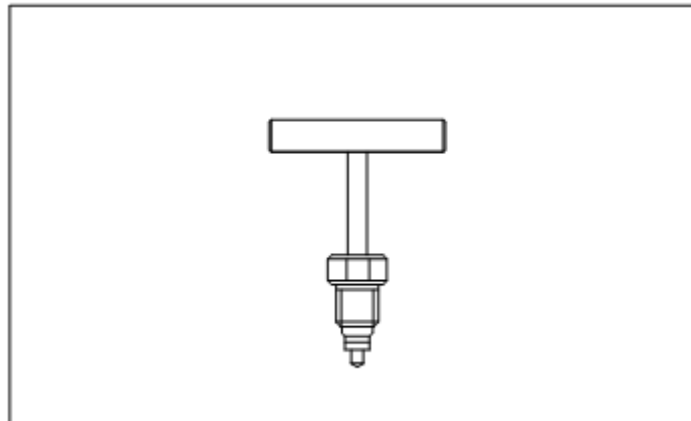

Figure 19

4. Place the valve body in a vise, or otherwise secure the assembly so it cannot move freely.
5. Rotate the handle counterclockwise until the valve is completely open (see Figure 20).
6. Very carefully, use a wrench to loose the nut about $\frac{1}{2}$ turn.
7. Again, very carefully, slowly rotate the handle and the large nut by hand.

NOTE: *KEEP THE HANDLE AND NUT STRAIGHT AND STEADY! The stem is a brittle, hardened metal, and will break easily.*

8. When the threads of the large nut are clear, firmly but gently pull the handle and stem straight out.

NOTE: ***DO NOT WIGGLE THE HANDLE ASSEMBLY IF THE ASSEMBLY IS TOO TIGHT TO REMOVE EASILY!** This is designed to handle high pressures without leakage, and therefore, has very tight tolerances. The stem is a brittle, hardened metal, and will break easily.*

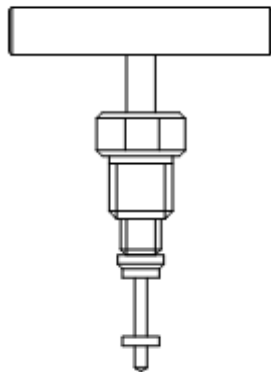

Figure 20

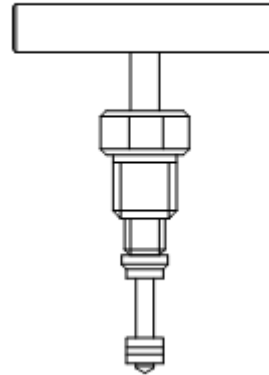

Figure 21

NOTE: *There are two types of valve assembly designs – one with the two followers and the packing ring (as illustrated in the accompanying tag)(Figures 22 & 23); and another with just one follower (Figures 20 & 21). The valve assembly with just one follower has a narrower stem, which can be more easily broken during disassembly. Therefore, it is important that you open the valve completely before unscrewing the large nut, and pulling the handle out straight after unscrewing the large nut. **THE FLOW VALVE WARRANTY IS VOIDED IF THE STEM IS BROKEN DURING DISASSEMBLY.***

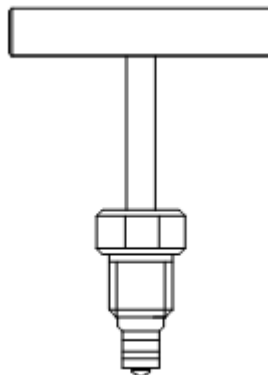

Figure 22

REASSEMBLING THE RAPID-FILL KIT

1. Ensure that the handle is turned completely counterclockwise.
2. Holding the handle and the large nut, gently insert the stem into the body of the valve (see Figures 19-23). (Make sure that the bracket is in place).
3. Manually rotate the handle and the large nut clockwise until the nut is hand-tight.

NOTE: *KEEP THE HANDLE AND NUT STRAIGHT AND STEADY! The stem is a brittle, hardened metal, and will break easily.*

4. Very carefully, use a wrench to tighten the nut until it is firmly secured (about a half-turn or so).
5. Position the bracket so it encircles the large nut (see Figure 19).
6. Secure the bracket to the valve body by tightening the bracket screw (see Figure 19).
7. Rotate the handle clockwise to close the valve.
8. Remove the assembly from the vise and install on the Rapid-Fill Kit.

REPLACEMENT PARTS OFR THE RAPID-FILL KIT

<u>DESCRIPTION</u>	<u>QUANTITY</u>	<u>PART NO.</u>
1/8 Plastic Tubing	1	330000-861
Piston retaining bracket	1	PC-414
Gland nut and sleeve	1	A-3338
Liquid inlet valve with handle	1	A-5022
Tube from valve to closure plug	1	PC-424
Pick-up tube	1	PC-408
Valve Mounting Bracket	1	PC-404
Retaining Plate	1	PC-412
Piston retaining bracket	1	PC-420

VII. SAFEGUARDS

A. THE PRESS



WARNING: THE POWER OUTLET MUST BE GROUNDED PROPERLY AND POLARIZED. IMPROPER GROUNDING COULD RESULT IN ELECTRIC SHOCK.

1. To eliminate the possibility of damage to the press pump motor, ensure that the AC line voltage and operating frequency is correct for the particular model of the press pump being used.
2. Do not operate the press until the hydraulic fluid reservoir is checked for the proper level.
3. For operation in ambient temperatures above 20°C (68°F), the hydraulic fluid supplied with the press (viscosity of 250-300 saybolt seconds universal [SSU] at 38°C [100°F]) is satisfactory. If operation in colder temperatures is anticipated, the use of a lower viscosity hydraulic fluid, such as Mobil DTE 24 or Shell Tellus 25 (not supplied), will be necessary for viscosity of 150 SSU.

To refill the press, use a high-grade industrial oil such as Mobil DTE 26 or Shell Tellus 33. The press is shipped with Mobil DTE 26.

4. For certain combinations of pressure and temperature, it is possible for the temperatures of the hydraulic fluid to increase to a point where its viscosity is lowered and the press will be unable to maintain sufficient pressure for the desired period of time. Turning off the pump motor will correct this condition by allowing the hydraulic fluid to cool down and regain its viscosity.

WARNING: ONLY THERMO IEC'S PRESSURE CELLS SHOULD BE USED WITH THE FRENCH PRESS. THERMO IEC PRESSURE CELLS ARE DESIGNED FOR, AND MUST ONLY BE USED FOR, BIOLOGICAL CELL DISRUPTION. USE THE FRENCH PRESSURE CELLS AND PRESS FOR OTHER USES MAY CREATE HAZARDOUS CONDITIONS RESULTING IN SEVERE PERSONAL INJURY, DEATH, OR PROPERTY DAMAGE.

5. The aligning pins on the lower platen of the press center the cell directly above the pressure actuating cylinder. Forces other than in a straight line through the cell cause scoring of the piston and possible damage to the inner wall of the cell body.

B. THE CELLS

WARNING: ONLY THERMO IEC'S PRESSURE CELLS SHOULD BE USED WITH THE FRENCH PRESS. THERMO IEC PRESSURE CELLS ARE DESIGNED FOR, AND MUST ONLY BE USED FOR, BIOLOGICAL CELL DISRUPTION. USE THE FRENCH PRESSURE CELLS AND PRESS FOR OTHER USES MAY CREATE HAZARDOUS CONDITIONS RESULTING IN SEVERE PERSONAL INJURY, DEATH, OR PROPERTY DAMAGE.

NOTE: *The contact of the piston and the closure plug at high pressure can damage the piston, closure plug, cell body, or all three. Damage caused by piston/closure plug contact at high pressure is not covered by the product warranty.*

PRECAUTION: **During the assembly and fill process, do not allow the piston to pick-up granules (e.g., sand, glass, dirt, etc.). A contaminated piston will irreversibly damage the inside of the cell.**

WARNING: **FRENCH Press and FFRENCH Pressure Cells are to be used only with samples of plant or animal cells. DO NOT put inappropriate materials (e.g., sand, glass, dirt, etc.) in the cell as this could result in an explosion, causing bodily injury.**

1. For your convenience, the sample outlet tube may be bent as desired to accommodate sample flow.
2. The flow valve should be finger tight. Turn the valve until you feel a slight resistance then turn it an extra 1/8 turn. Excessive pressure to tighten the valve can distort the shape of the nylon ball and may lead to leaking problems.
3. The sleeves on both ends of the connecting tube should be screwed on (left-hand thread) until approximately one thread is exposed. When the nut is tightened into the high pressure connection, the conical end of the tube is forced into the seat, affecting the seal.
4. Do not overpressurize the cells. Before applying pressure to the cell, determine the gauge pressure required to produce the desired pressure in the cell. If the maximum working pressure is exceeded, the seals and/or cell itself could rupture causing injury to the operator.

<u>PART NUMBER</u>	<u>MAXIMUM WORKING PRESSURE</u>	<u>MAXIMUM FORCE PRESSURE</u>	<u>MAXIMUM GAUGE READING "HIGH" RANGE</u>
FA-032 (40K)	40,000 psi	31,416 lbs	2,520 psi
FA-003 (MIN)	20,000 psi	2,200 lbs	900 psi (MED range only)

DO NOT OPERATE THE CELLS ABOVE THEIR PRESSURE RATINGS. OPERATE FA-003 (Mini-Cell) IN MED RANGE ONLY.

5. The flow valves on the cells are extremely sensitive. To achieve the 15 drops/min flow rate, gently finger tap the valve handle.

VIII. SPECIFICATIONS

A. THE PRESS

Height: 34.5 in (87.6 cm)
Weight: 240 lbs (109 kg)
(shipping): 320 lbs. (145 kg)
Dimensions: 18.25 in x 18.25 in
(46.4 m x 46.4 m)
Power requirements (FA-078A): 120V \pm 10%, 60Hz
(FA-078A-E1): 220V \pm 10%, 50Hz
(FA-078A-E2): 240V \pm 10%, 50Hz

B. THE 40K CELL

Diameter: 3" OD (7.6 cm)
Closed Height: 11.38 in (28.9 cm)
Open Height: 14.0 in (35.6 cm)
Sample Capacity: 35 ml
40K Maximum Working Pressure: 40,000 psi
Minimum volume, first run: 1.0 ml
Minimum volume, additional runs: 0.5 ml
Maximum volume: 40 ml

C. THE MINI-CELL

Diameter: 2.38 in (6.0 cm)
Closed Height: 6.13 in (15.6 cm)
Open Height: approx. 8.12 in to 8.25 in
(approx. 20.6 cm to 21 cm)
Sample Capacity: 3.7 ml
Maximum Working Pressure: 20,000 psi
Maximum Compressive Force On Piston: 2200 lbs (999 kg). A reading of 900 lbs on the
FRENCH Press at MED range.
Minimum volume, first run: 0.37 ml
Minimum volume, additional runs: 0.3 ml
Maximum volume: 3.7 ml