



New Brunswick™ I24/24R Benchtop Incubator Shaker

Operating manual

Copyright © 2014 Eppendorf AG, Germany. No part of this publication may be reproduced without the prior permission of the copyright owner.

Eppendorf® and the Eppendorf logo are registered trademarks of Eppendorf AG, Germany.

New Brunswick™ is a trademark of Eppendorf AG, Germany.

Trademarks are not marked in all cases with ™ or ® in this manual.

Table of contents

1	Operating instructions	5
1.1	Using this manual	5
1.2	Danger symbols and danger levels	5
1.2.1	Hazard icons	5
1.2.2	Degrees of danger	5
1.3	Symbols used	6
2	Safety	7
2.1	Warnings for intended use	7
2.1.1	Warning	7
2.1.2	Caution	7
3	Product description	9
3.1	Overview	9
3.2	Control panel	10
3.3	Keypad	11
3.4	User interface keys	11
3.5	LED Display	12
3.6	Status indicators	12
3.7	Function indicators	13
3.8	Optional features	13
3.9	Refrigeration schematic	14
4	Installation	15
4.1	Inspection of boxes	15
4.2	Packing list verification	15
4.3	Unpacking of equipment	15
4.4	Out of box concerns	15
4.5	Physical location	16
4.6	Environment	16
4.7	Electrical requirements	16
4.8	Space requirements	16
4.9	Installation of platform	18
4.9.1	Directions	19
4.10	Flask clamp installation	19
4.10.1	To install these double girdle clamps:	19
4.11	Electrical connections	21
5	Operation	23
5.1	Electrical connection	23
5.2	Starting the shaker	23
5.3	Continuous (untimed) run	24
5.3.1	Directions	24
5.4	Checking setpoints	24
5.5	Timed functions	25
5.5.1	To set the timer	25
5.6	Alarm functions	25
5.6.1	Directions	25

Table of contents

New Brunswick™ I24/24R Benchtop Incubator Shaker
English (EN)

5.7	Temperature setpoint	26
5.8	Temperature offset calibration	26
5.9	Power failure	27
5.10	Speed calibration	27
6	Troubleshooting	29
6.1	Troubleshooting	29
7	Maintenance	33
7.1	Routine maintenance	33
7.2	Cleaning external & internal surfaces	33
7.3	Biohazard decontamination	34
8	Technical data	35
8.1	Specifications	35
9	Ordering information	37
9.1	Accessories	37
9.2	Platforms	37
9.3	Flask clamps for Universal Platforms	38
9.4	Replacement clamp hardware kits	38
9.5	Test tube racks & other accessories	39
9.6	Remote alarm option	39
10	Transport, storage and disposal	41
10.1	Disposal	41
	Index	42





1 Operating instructions

1.1 Using this manual

- ▶ Carefully read this operating manual before using the device for the first time.
- ▶ Also observe the operating manual enclosed with the accessories.
- ▶ The operating manual should be considered as part of the product and stored in a location that is easily accessible.
- ▶ When passing the device on to third parties, be sure to include this operating manual.
- ▶ If this manual is lost, please request another one. The latest version can be found on our website www.eppendorf.com (international) or www.eppendorfnna.com (North America).

1.2 Danger symbols and danger levels

1.2.1 Hazard icons

	Electric shock		Crushing
	Biohazard		Hazard point
	Heavy loads		

1.2.2 Degrees of danger

The following danger levels are used in safety messages throughout this manual.

DANGER	<i>Will</i> lead to severe injuries or death.
WARNING	<i>May</i> lead to severe injuries or death.
CAUTION	May lead to light to moderate injuries.
NOTICE	May lead to material damage.

Operating instructions

New Brunswick™ I24/24R Benchtop Incubator Shaker
English (EN)

1.3 Symbols used

Example	Meaning
▶	You are requested to perform an action.
1. 2.	Perform these actions in the sequence described.
•	List.
	References useful information.

2 Safety

2.1 Warnings for intended use

2.1.1 Warning



WARNING!

- ▶ Do not attempt to lift the I24/24R by yourself.
- ▶ Always ask for assistance or use a lifter or other suitable equipment when raising or handling the unit.



WARNING! Heavy!

- ▶ It is preferable to lift the I24/24R from the sides of the unit, but if you lift it from the front and back, be sure to use the finger holes in the back lip (toward the bottom of the unit).
- ▶ If these finger holes are not used, the back lip can pinch fingers and hands.



WARNING!

- ▶ When cleaning the unit, always turn off the shaker and disconnect the power cord from the power supply.



WARNING!

- ▶ Personnel involved in the cleanup of any spill should wear gloves, safety glasses, and a laboratory coat or gown during the cleanup process.
 - ▶ Respiratory protection should be considered for spills where aerosolization is suspected.
-

2.1.2 Caution



CAUTION!

- ▶ This equipment must be operated as described in this manual. If operational guidelines are not followed, equipment damage and personal injury can occur.
- ▶ Please read the entire User's Guide before attempting to use this unit.
- ▶ Do not use this equipment in a hazardous atmosphere or with hazardous materials for which the equipment was not designed.
- ▶ Eppendorf, Inc. is not responsible for any damage to this equipment that may result from the use of an accessory not manufactured by Eppendorf.



CAUTION!

- ▶ A grounded electrical outlet is necessary for the safe operation of this instrument.
-

Safety

New Brunswick™ I24/24R Benchtop Incubator Shaker
English (EN)

3 Product description

3.1 Overview

The I24/24R Benchtop Incubator Shakers use a triple eccentric counter-balanced drive mechanism. They provide horizontal plane rotary motion in a 1.9 cm (¾ in) or 2.5 cm (1 in) diameter circular orbit. A Proportional/Integral (PI) microprocessor controls the speed and temperature over the entire range.

The incubated and refrigerated 24R operates from 15 °C below ambient (with a minimum setpoint of 4 °C) to 60 °C, and the incubated I24 from 5 °C above ambient to 60 °C. Both these ranges depend on relative humidity and other ambient factors. Ambient temperature is measured one meter from the front of the unit.

Erlenmeyer flasks, 2.8 L Fernbach flasks, and a wide variety of tubes and plates can be accommodated using the shaker accessories (see *Accessories on p. 37*).

The I24/24R may be operated in the following ways:

- **Continuously:** at a set speed and temperature, until user intervention.
- **In a timed mode:** run at a set speed, time and temperature for a period of up to 99.9 hours, after which the shaker automatically shuts off, while the temperature is maintained at its setpoint.

For safe operation, the I24/24R shakers are designed with a safety switch that automatically stops the shaker mechanism when the lid is opened.

Both the I24 and the 24R are equipped with visual and audible alarms that alert the user to the following conditions:

- The end of a timed run
- Deviations from speed setpoint (5 minutes after hood is closed)
- Deviations from temperature setpoint (5 minutes after hood is closed)
- Power failure
- Lid (hood) open

To accommodate customer needs, a wide variety of platforms can be used with the I24/24R:

- Universal platforms are the most flexible, providing hole patterns for flask clamps, test tube racks and other accessories.
- Dedicated platforms are supplied with flask clamps attached; they are designed solely and expressly for this purpose.
- Test tube racks, microplate holders, and test tube rack holders are also available (a universal platform is needed for all test tube racks and holders).

For further information on these accessories, (see *Accessories on p. 37*).

Product description

New Brunswick™ I24/24R Benchtop Incubator Shaker
English (EN)

**CAUTION!**

- ▶ This equipment must be operated as described in this manual. If operational guidelines are not followed, equipment damage and personal injury can occur.
- ▶ Please read the entire User's Guide before attempting to use this unit.
- ▶ Do not use this equipment in a hazardous atmosphere or with hazardous materials for which the equipment was not designed.
- ▶ Eppendorf, Inc. is not responsible for any damage to this equipment that may result from the use of an accessory not manufactured by Eppendorf.

3.2 Control panel

The front panel (see figure below) of the I24/24R shakers provides easy access to the control panel, which consists of the keypad, display and indicator lights. The **ON/OFF** switch is conveniently located on the right side of the unit, as you face the controls.

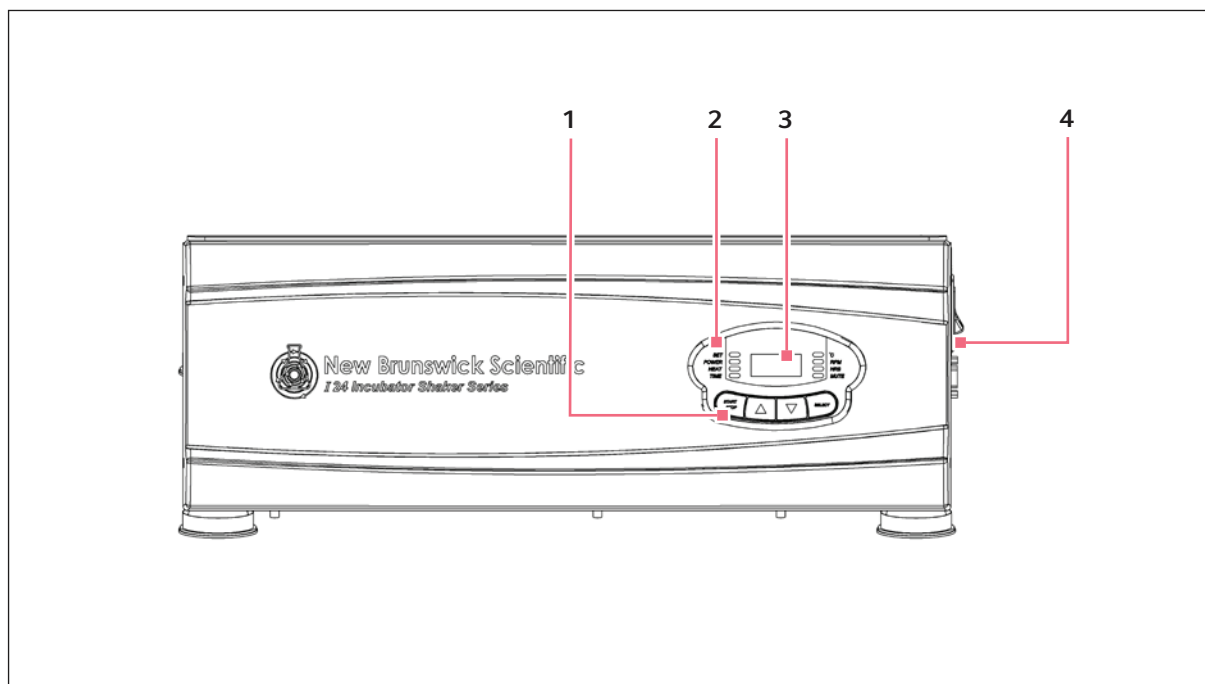

Fig. 3-1: Control panel

1 Keypad

2 Indicators

3 LED display

4 ON/OFF switch

3.3 Keypad

The keypad (see Fig. 3-2 on p. 11) is the operator’s command center for the shaker. In one convenient location are grouped the user interface keys, the LED display, the status indicator lights and the function indicator lights.

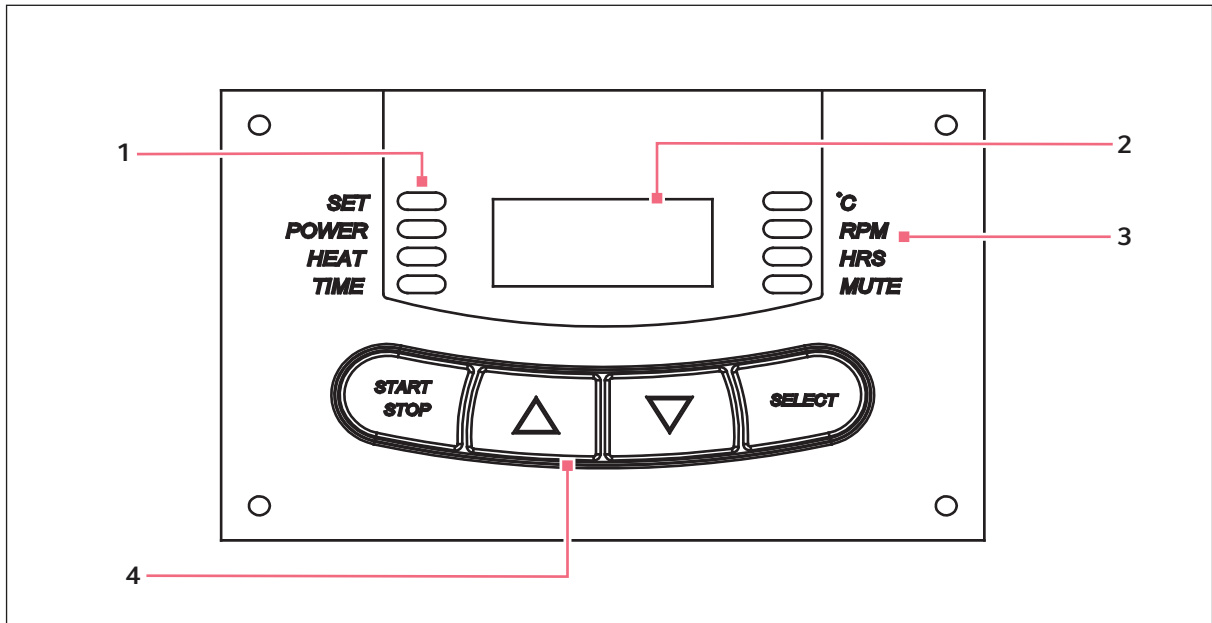

Fig. 3-2: Keypad

1 Status indicators

3 Function indicators

2 LED display

4 User interface keys

3.4 User interface keys

START/STOP	This key is used to start or stop the shaker. It will also activate or stop the timer when a timed run is desired.
SELECT	This key is used to change the displayed parameter.
▲ (UP), ▼ (DOWN)	These keys are used to adjust the setpoint of a displayed parameter up or down. They also allow the user to enter the SET MODE for setpoint changes.

Product description

New Brunswick™ I24/24R Benchtop Incubator Shaker
English (EN)

3.5 LED Display

The digital display on the control panel is a three-digit **LED DISPLAY**. During normal shaker operation, the display will indicate:

- Shaker status (On/Off)
- Shaking speed
- Chamber temperature
- Setpoints
- Hours remaining (in a timed run)
- Lid open (“LID”)

3.6 Status indicators

Four status indicator lights are located to the left of the **LED DISPLAY**. They are:

SET	Indicates that the shaker is in the SET MODE , when setpoints are being displayed and can be altered. This is activated by the SELECT key or by pressing the ▲ (UP) or ▼(DOWN) arrow.
POWER	Illuminates and blinks during power up or if power is interrupted during a run. Press the SELECT key and change to another function to turn off this indicator.
HEAT	Illuminates to indicate that the heater is on.
TIME	Indicates that the timer is in operation. The shaker can be programmed to run for a preset time from 0.1 – 99.9 hours. The timer can be disengaged without stopping an ongoing run.

3.7 Function indicators

Four function indicator lights are located to the right of the **LED DISPLAY**. They indicate the current parameter(s) being displayed:

°C	Interior chamber temperature. Can be set from 4 °C – 60 °C, when in SET MODE , using the ▲ (UP) or ▼ (DOWN) arrow key. It indexes at 0.1 °C increments unless the key is pressed for 4 seconds, after which it indexes more rapidly.
RPM	Revolutions per minute. When in SET MODE , use the ▲ (UP) or ▼ (DOWN) arrow key to change the speed. It indexes at 1 RPM increments unless the key is pressed for 4 seconds, after which it indexes more rapidly.
HRS	Time remaining in a timed run. Can be set from 0.1 – 99.9 hours, in 0.1 increments or, if the ▲ (UP) or ▼ (DOWN) arrow key is pressed for 4 seconds, the time indexes more rapidly. The countdown begins when the START/STOP key is pressed. If the START/STOP key is pressed, the shaking stops (but temperature is maintained) and the timer pauses until the START/STOP key is pressed again. When a timed run ends, the HRS indicator will blink. Press the SELECT key and change to another function to turn off this indicator.
MUTE	This feature is controlled by the SELECT key. When activated, the audible alarm is muted, and remains so until is is reactivated. If MUTE is activated when the shaker is turned off using the ON/OFF switch, it will remain engaged when the machine is powered up again. To activate (or deactivate) the MUTE function, press the SELECT key until the MUTE indicator illuminates; press the ▲ or ▼ KEY to display ON or OFF , as desired; then press SELECT .

3.8 Optional features

A remote alarm option is available for factory installation (see *Remote alarm option on p. 39*).

Product description

New Brunswick™ I24/24R Benchtop Incubator Shaker
English (EN)

3.9 Refrigeration schematic

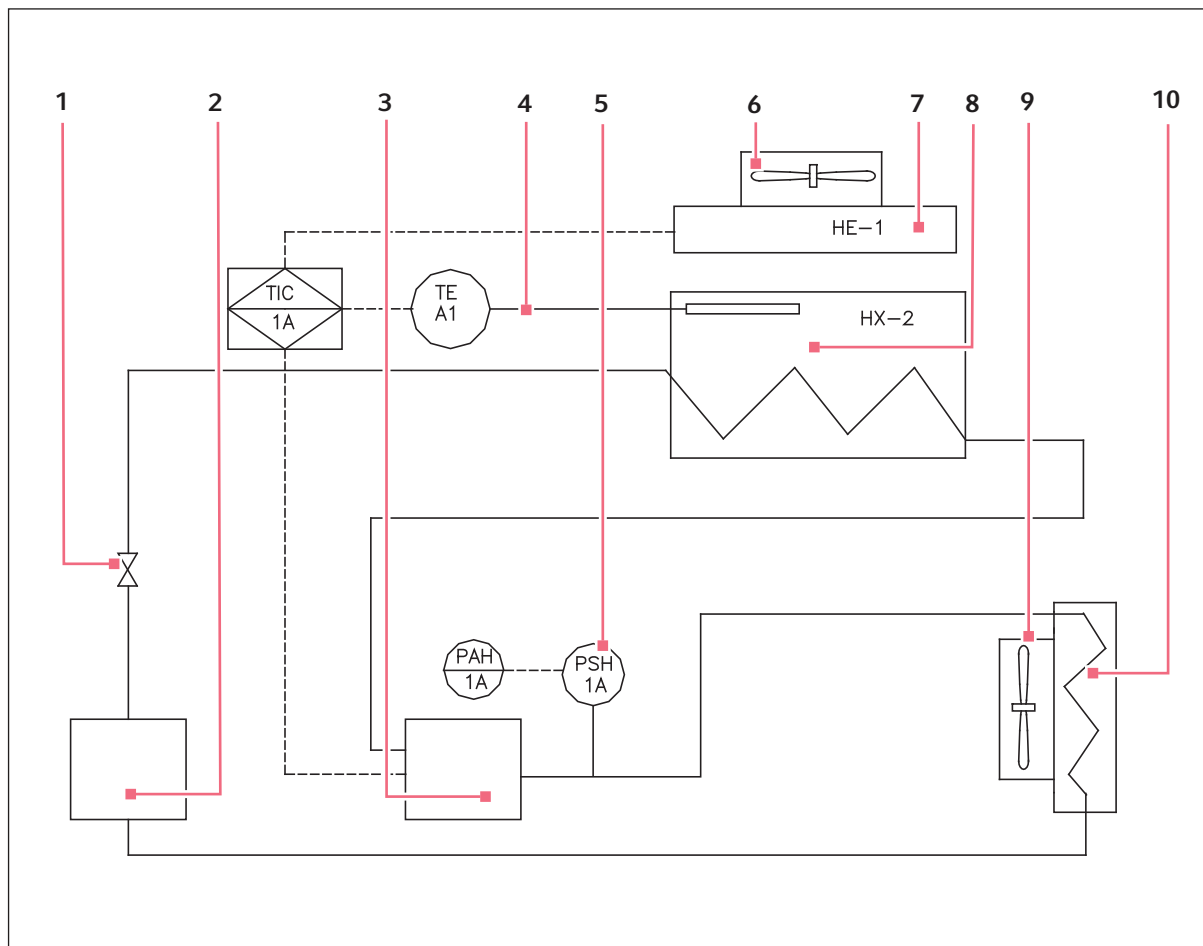

Fig. 3-3: Refrigeration schematic

- | | |
|-----------------------|----------------|
| 1 Flow control device | 6 Evap. fan(s) |
| 2 Filter dryer | 7 Heater |
| 3 Comp. | 8 Evaporator |
| 4 Temp control probe | 9 Cond. fan(s) |
| 5 Pressure switch | 10 Condenser |

4 Installation

4.1 Inspection of boxes

After you receive your order from Eppendorf, inspect the boxes carefully for any damage that may have occurred during shipping. Report any damage immediately to the carrier and to your local Eppendorf Customer Service Department.

4.2 Packing list verification

Verify against your Eppendorf packing list that you have received all of the correct materials.

4.3 Unpacking of equipment



WARNING!

- ▶ Do not attempt to lift the I24/24R by yourself. Always ask for assistance or use a lifter or other suitable equipment when raising or handling the unit.



WARNING! Heavy!

- ▶ It is preferable to lift the I24/24R from the sides of the unit, but if you lift it from the front and back, be sure to use the finger holes in the back lip (toward the bottom of the unit). If these finger holes are not used, the back lip can pinch fingers and hands.

Upon unpacking the unit, inspect it carefully for any damage that may have occurred during transit. Report any apparent damage to the carrier and to your sales representative. Save the crate and packing materials.



Use of the I24/24R Shakers requires a platform, which is a separate item (see *Platforms* on p. 37).

4.4 Out of box concerns

If any part of your order was damaged during shipping, is missing pieces, or fails to operate properly, please contact your sales representative.

Installation

New Brunswick™ I24/24R Benchtop Incubator Shaker
English (EN)

4.5 Physical location

**WARNING!**

- ▶ Do not attempt to lift the I24/24R by yourself. Always ask for assistance or use a lifter or other suitable equipment when raising or handling the unit.

**WARNING! Heavy!**

- ▶ It is preferable to lift the I24/24R from the sides of the unit, but if you lift it from the front and back, be sure to use the finger holes in the back lip (toward the bottom of the unit). If these finger holes are not used, the back lip can pinch fingers and hands.
-

The surface where you place the I24/24R should be smooth, level and sturdy, and must be able to accommodate 200 pounds.

4.6 Environment

The shaker is designed to operate optimally in the following ambient conditions:

- 10 ° – 35 °C
- 20 – 80 % Relative Humidity (non-condensing)

4.7 Electrical requirements

The I24/24R runs on 120 Volts, 60 Hz, 1500 VA maximum. Voltage variations must not exceed ± 10 %.

4.8 Space requirements

It is essential that the shaker be situated in an area where there is sufficient space for the unit and its service lines (see Fig. 4-1 on p. 17).

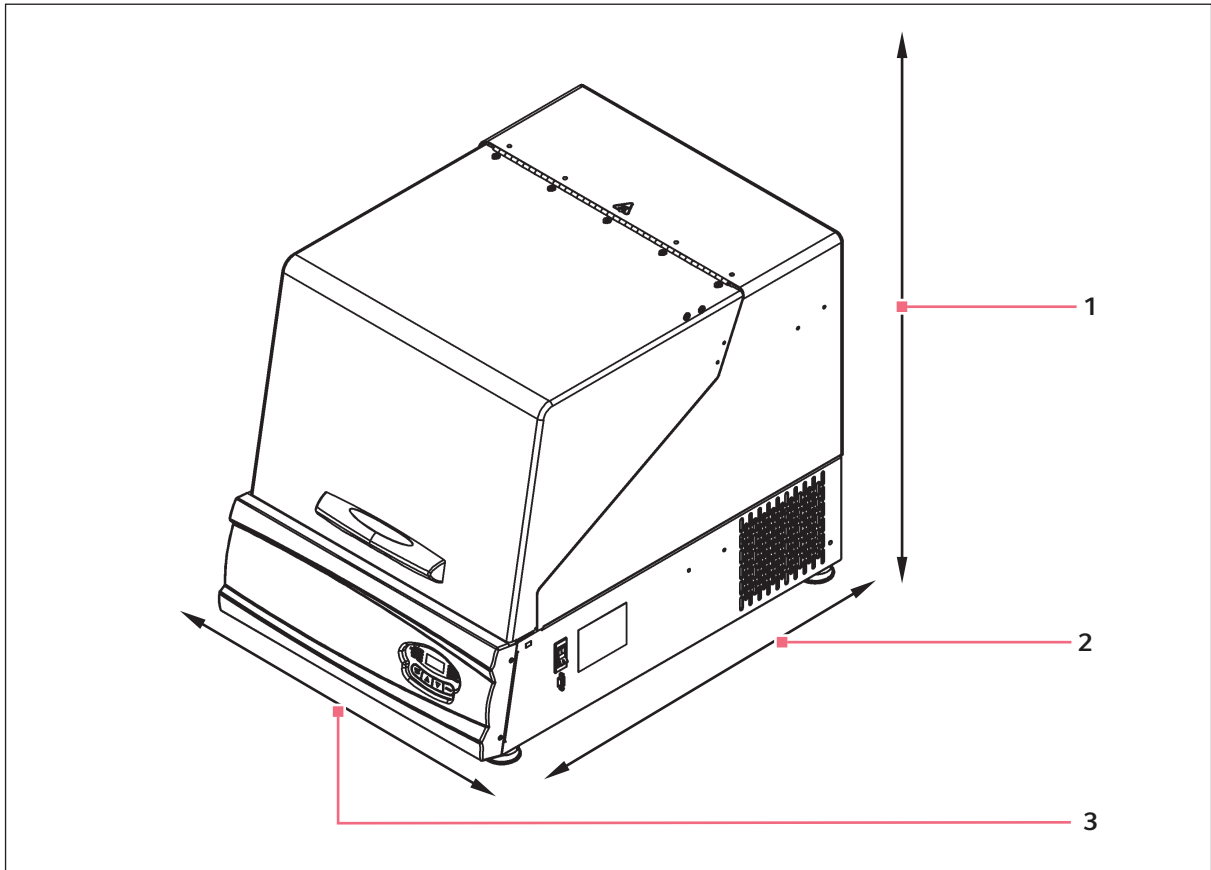

Fig. 4-1: Space requirements

- 1 Allow 42 in of height to provide clearance for opening the lid
- 2 Allow 33 in of depth to provide clearance
- 3 Allow 27 in of width to provide clearance

The dimensions of the I24/24R are:

Width	22 in	55.8 cm
Depth	30 in	76.2 cm
Height	24 1/16 in	61.1 cm
Height with lid open	40 1/2 in	101.9 cm



Be sure to allow at least three inches (7.6 cm) around shaker for ventilation, access to power cord (rear panel), and access to power switch and RS-232 port (right side).

Installation

New Brunswick™ I24/24R Benchtop Incubator Shaker
English (EN)

The effective surface area required for operation is:

Width	24 in	61 cm
Depth	30 in	76.2 cm

4.9 Installation of platform



There are two small plastic straps that hold the bearing housing in place for shipping. The straps must be removed from the unit.

Prior to use, a platform must be installed on the unit. The unit is shipped with four Allen head **PLATFORM SCREWS** installed in the **UPPER BEARING HOUSING**. These screws must be removed and set aside for use before a platform can be installed:

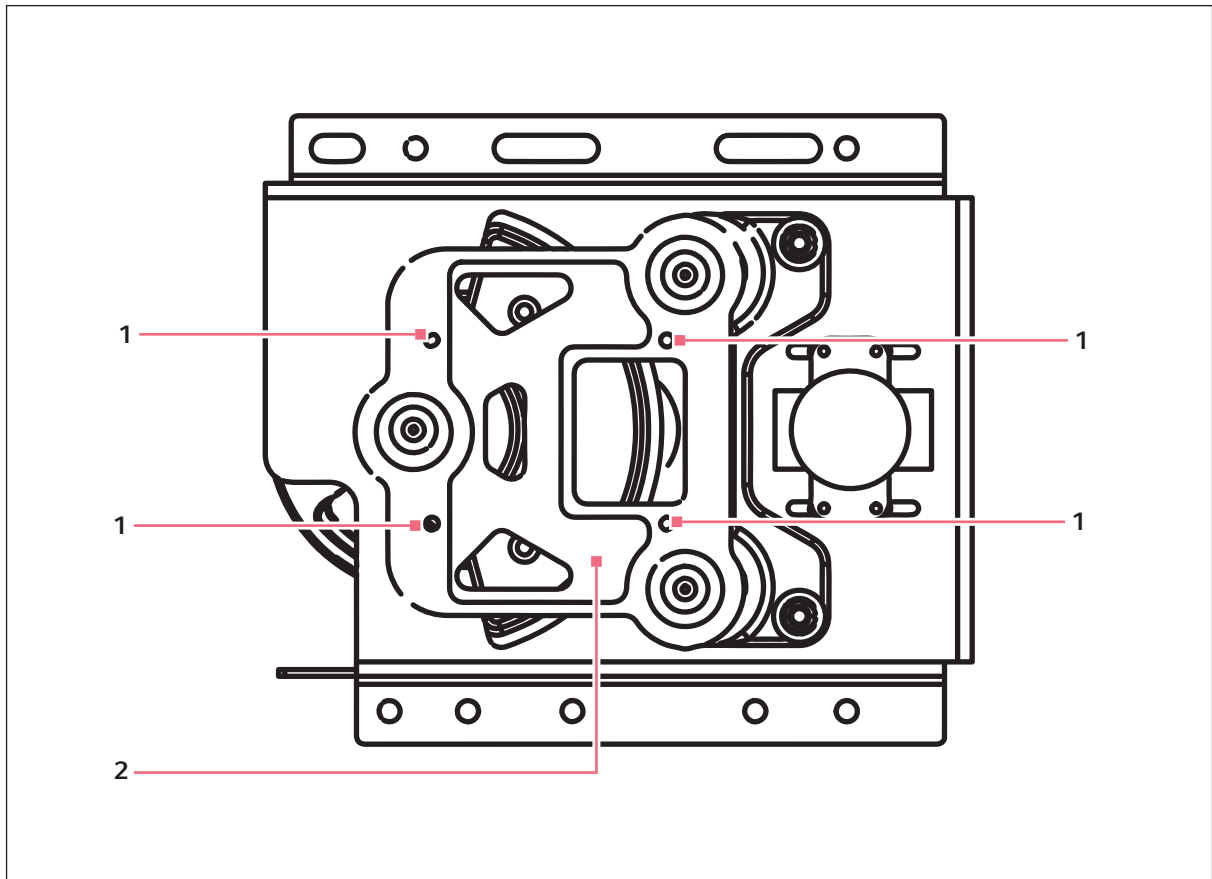

Fig. 4-2: Platform screw locations

1 Platform screw

2 Upper bearing housing

4.9.1 Directions

1. Using the 5/32-in hex wrench provided, remove the four Allen head platform screws from the subplatform. Set them aside.
2. Place the selected **PLATFORM** on the subplatform. Align the mounting holes of the platform with the platform screw locations in the subplatform.
3. Insert the four Allen head platform screws previously removed and set aside. Tighten them with the 5/32-in hex wrench provided to secure the platform.

4.10 Flask clamp installation

Flask clamps purchased for use with universal platforms require installation (see *Platforms on p. 37*). Clamps are installed by securing the base of the clamp to the platform with the correct type and number of screws. All clamps are shipped complete with hardware.



The I24/24R platforms require 10 – 24 x 5/16-inch screws, which are the smaller Phillips head screws supplied, to fasten flask clamps.

Clamps for 2 and 2.8 L flasks are shipped with an additional girdle to keep the flasks in place. The girdle is an assembly of springs and sections of rubber tubing. One girdle is already in place on the clamp, the other is packed separately.

4.10.1 To install these double girdle clamps:

1. Place the clamp on the platform, aligning its mounting holes with holes on the platform. Secure the clamp in place using the flat Phillips head screws provided (#S2116-3051, 10-24 x 5/16-inch). *Use the following two figures to help you identify the proper screws, as three different types of screws are shipped with the clamps.*
2. With the first girdle in place, as delivered, on the upper part of the clamp body (see Fig. 4-3 on p. 20), insert an empty flask into the clamp.
3. After making sure the sections of tubing are located between the clamp legs, roll the first girdle down the legs of the clamp as far as it can go. The tubing sections will rest against the platform, and the springs will be under the clamp base.
4. Place the second girdle around the upper portion of clamp body (just as the first girdle was initially). Make sure that its spring sections rest against the clamp legs, while its rubber tubing sections sit against the flask, in between the clamp legs.

Installation

New Brunswick™ I24/24R Benchtop Incubator Shaker
English (EN)

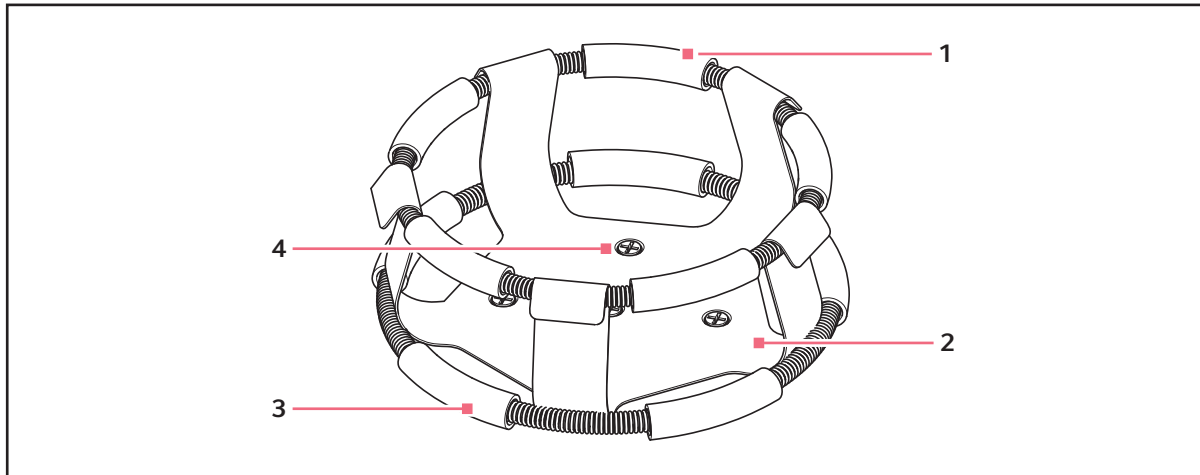

Fig. 4-3: Double girdle clamp installation

1 Upper girdle with girdle tubes

3 Lower girdle with girdle tubes

2 Clamp body (legs and base)

4 Clamp mounting holes (5)



Fig. 4-4: Clamp fastener



The upper girdle secures the flask within the clamp, and the bottom girdle keeps the flask from spinning.

Flask clamps are used on a variety of shaker platforms. Flat head screws of different lengths and thread pitch are used to secure the clamp. With reference to the figure above, select the appropriate screws and set the others aside.



One-liter and larger flask clamps are fastened with 5 screws.

4.11 Electrical connections



CAUTION!

- ▶ A grounded electrical outlet is necessary for the safe operation of this instrument.
-

Before making electrical connections, be sure to check the following:

1. If you have not already done so, check that the voltage and frequency of your unit are compatible with your electric supply.
2. Remove the caution label from the rear of the unit.
3. Set the circuit breaker on the right side of the unit to the OFF position.
4. **ONLY THEN:** Plug the power cord into a grounded electrical outlet.

Installation

New Brunswick™ I24/24R Benchtop Incubator Shaker
English (EN)

5 Operation

5.1 Electrical connection

Before making electrical connections, verify that the power source voltage matches the voltage on the **ELECTRICAL SPECIFICATION PLATE** and that the **ON/OFF SWITCH** is on the **OFF** position. The **ELECTRICAL SPECIFICATION PLATE** is located on the rear panel of the unit near the **POWER CONNECTOR**. Connect the **POWER CORD** to the **POWER CONNECTOR** (Universal Voltage Input Module) on the rear panel, then connect the other end to a suitable, grounded receptacle.

5.2 Starting the shaker

To initially start the shaker, close the lid and turn the **ON/OFF SWITCH** on the right side panel of shaker to the **ON** position. During start-up, the LED display will indicate the model of your shaker. When the shaker begins to operate, the **LED DISPLAY** will track the speed as it accelerates to the last entered setpoint. The shaking action may be started or stopped by pressing the **START/STOP KEY** on the **KEYPAD**.

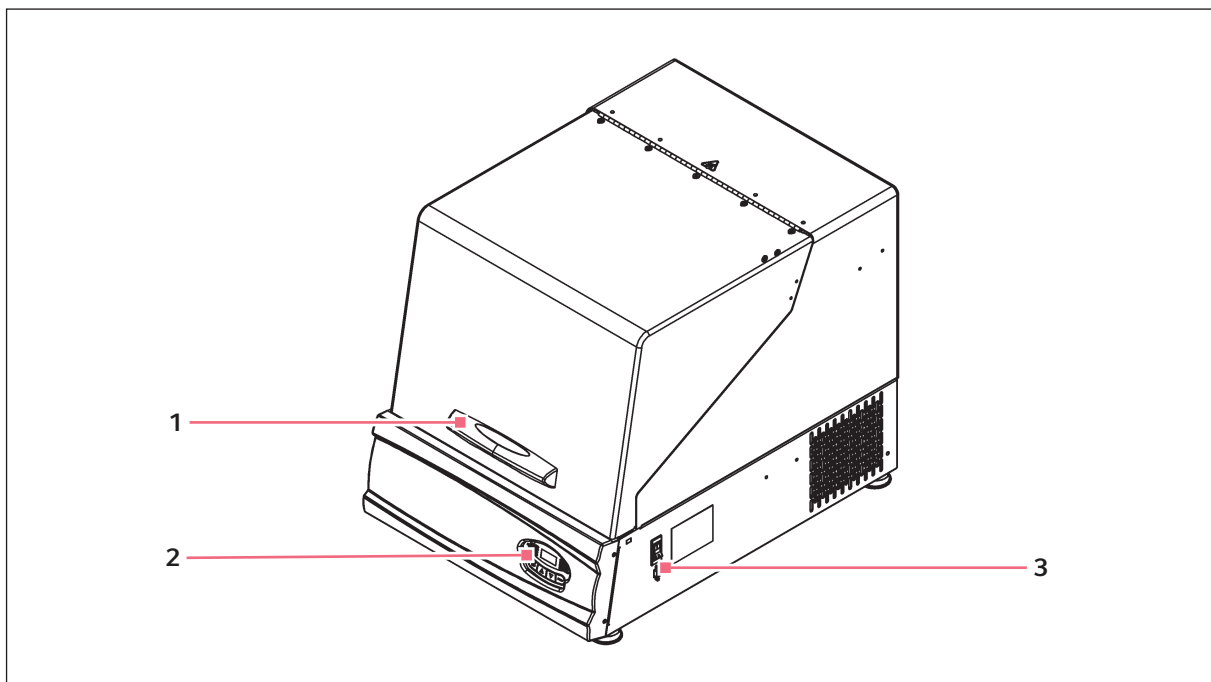

Fig. 5-1: ON/OFF Switch location

1 Lid handle

3 ON/OFF Switch

2 Keypad



The shaker will not operate if the lid is open.

Operation

New Brunswick™ I24/24R Benchtop Incubator Shaker
English (EN)

5.3 Continuous (untimed) run

5.3.1 Directions

1. Press SELECT until the RPM INDICATOR is illuminated.
2. If the display indicates that the shaker is OFF, press the START/STOP KEY.
3. Press either ▲ (UP) or ▼ (DOWN) KEY to enter SET MODE (the SET INDICATOR will illuminate).
4. Set the speed by using the ▲ or ▼ KEY until the desired setpoint is displayed. Continued pressure on the ▲ or ▼ KEY will cause the setting to change more rapidly.



The setpoint may be changed during a run without stopping the shaker by following steps 2 – 4 above. During speed changes, a visual alarm (flashing RPM INDICATOR) will flash and an audible alarm will sound until the speed returns to within 5 rpm of the setpoint.

5.4 Checking setpoints

To check any setpoint:

1. Press the SELECT key until the desired indicator is lit.
2. Press either ▲ or ▼ to enter the SET mode and display the current setpoint.



Holding the ▲ or ▼ key for more than 0.5 second causes the setpoint to change. Should this occur, resetting will be necessary.

5.5 Timed functions

The shaker may be programmed to automatically stop after a preset time period of 0.1 – 99.9 hours. There must be power to the shaker in order to set the timer, although a timed run can be initiated while the unit is either stopped or operating.

5.5.1 To set the timer

1. Press the **SELECT KEY** until the **HRS INDICATOR** is illuminated.
2. Press either **▲** or **▼ KEY** to enter the **SET MODE** and set the desired run time, between 0.1 – 99.9 hours.



If the shaker is stopped, skip to Step 5 below. If the shaker is already running:

3. Press the **START/STOP KEY**. The shaker will stop and the display will read **OFF**.
4. Press the **START/STOP KEY** again; the **TIME INDICATOR** will light and the shaker will start the timed run.



If the shaker is stopped:

5. Press the **START/STOP KEY**. The shaker will start in untimed mode.
6. Press the **START/STOP KEY** again. The shaker will stop and the display will read **OFF**.
7. Press the **START/STOP KEY** a third time; the **TIME INDICATOR** will light and the shaker will start the timed run.

To disable the visual alarm (flashing **TIME INDICATOR**), press the **SELECT KEY** and change to any other function.

To cancel the timer without stopping the shaker:

Repeat steps 1 and 2 above, then immediately press the **START/STOP KEY**. The **TIME INDICATOR** will cease to flash and the display will read **OFF**.

5.6 Alarm functions

The I24/24R shakers have an audible alarm that is activated at predetermined times, as explained in (see *Overview on p. 9*). It can be deactivated by using the **MUTE** function:

5.6.1 Directions

1. Press the **SELECT** key until the **MUTE** indicator illuminates.
2. Press the **▲** or **▼ KEY** to display **ON**, then press the **SELECT KEY**.



To reactivate the audible alarm:

3. Press the **SELECT** key until the **MUTE** indicator illuminates.
4. Press the **▲** or **▼ KEY** to display **OFF**, then press the **SELECT KEY**.

Operation

New Brunswick™ I24/24R Benchtop Incubator Shaker
English (EN)

5.7 Temperature setpoint

Press the **SELECT KEY** until the function **°C INDICATOR** illuminates. The temperature can be set from 5 °C above ambient temperature to 60 °C (non-refrigerated units) or from 4 °C – 60 °C (refrigerated units). Increasing or decreasing the setpoint is accomplished with the **▲** or **▼ KEY**.

During operation, if the temperature of the chamber is more than 1.0 °C higher or lower than the temperature setpoint, an alarm is triggered. This alarm consists of a flashing **°C INDICATOR** and audible beep. The alarm will automatically deactivate as the unit achieves the set temperature.

5.8 Temperature offset calibration

The temperature probe and the temperature controller are calibrated together at the factory. The temperature probe measures the temperature of the air at the probe's location, near the heat exchanger return vent. The controller uses the probe input to adjust air temperature, up or down, to match the temperature setpoint.

Depending on various conditions within the chamber, such as flask placement and size, the heat produced by growing organisms, heat losses due to liquid evaporation from flasks, etc., the display temperature may differ from temperatures within the flasks themselves.

If you wish to have the temperature display (*Indicated Temperature*) match the temperature at a given point, or match the average of a series of points within the chamber (*Actual Temperature*), proceed as follows:

1. Let the unit equilibrate at or near the desired temperature. Record the Indicated Temperature.
2. Record the Actual Temperature.
3. Calculate the temperature correction value: Actual Temperature – Indicated Temperature = Temperature Correction Value.
4. Press the SELECT key until the function °C indicator illuminates.
5. Simultaneously press the ▲(Up) and ▼(Down) keys. The display will indicate CAL.
6. Using the ▲(Up) or ▼(Down) key, enter the Temperature Correction Value calculated in Step 3.
7. Simultaneously press the ▲(Up) and ▼(Down) keys to save the Temperature Correction Value to memory.



The °C light will pulse rapidly to indicate it is not operating in the factory default mode.
The °C light will pulse rapidly to indicate it is not operating in the factory default mode.

1. Press the SELECT key until the function °C indicator illuminates.
2. Simultaneously press the ▲(Up) and ▼(Down) keys. The display will indicate CAL.
3. Using the ▲(Up) or ▼(Down) key, set the Temperature Correction Value to zero.
Simultaneously press the ▲(Up) and ▼(Down) keys. The rapid pulsing of the °C indicator will stop.

5.9 Power failure

In the event of a power failure, the I24/24R shakers are equipped with an **automatic restart function**.

If the shaker was in operation prior to the power interruption, the shaker will begin to operate at its last entered setpoint. The **LED DISPLAY** will flash, indicating that a power failure has occurred. Press any key to stop the flashing of the **LED** display.

5.10 Speed calibration

To calibrate the shaking speed:

1. Set the shaker to a speed that can easily be measured. If you are using a strobe, minimum speed should be 250 rpm.
2. Compare the reading on the display to the measured reading.

If an adjustment is needed:

1. Press the SELECT key until the RPM indicator light illuminates.
2. Press the ▲ (Up) and ▼ (Down) keys simultaneously. The display will indicate CAL.
3. Press either the ▲ (Up) or ▼ (Down) key to change the displayed value to match the measured speed.
4. Press the ▲ (Up) and ▼ (Down) keys simultaneously to save the adjustment.
5. Turn shaker Off using the power switch, then turn it back On.

Operation

New Brunswick™ I24/24R Benchtop Incubator Shaker
English (EN)

6 Troubleshooting

6.1 Troubleshooting

If any problems occur with your shaker, do not attempt to perform any service on the unit other than specified in this manual. Unauthorized servicing may void the warranty. Please contact your local Eppendorf Customer Service Department.

In any correspondence with Eppendorf, please refer to the model number and serial number of your unit. This information is on the electrical specification plate, located on the rear panel of the unit, above the power connector.

There are some problems, however, that you can investigate and correct yourself. Refer to the following Troubleshooting Guide:

Troubleshooting

New Brunswick™ I24/24R Benchtop Incubator Shaker
English (EN)

Symptom	Cause	Solution
Shaker does not run	<ul style="list-style-type: none"> • No power • Display is not on • Power cord is not plugged in and/or power switch is off 	<ul style="list-style-type: none"> ▶ Plug in power cord (to working electric outlet) and turn on power switch
	<ul style="list-style-type: none"> • Door is open 	<ul style="list-style-type: none"> ▶ Close door firmly, making sure latch is engaged
	<ul style="list-style-type: none"> • Door is closed but not completely • Door magnet is not adjusted correctly • On/Off switch is not working 	<ul style="list-style-type: none"> ▶ Call for service
	<ul style="list-style-type: none"> • Tilt switch has been triggered 	<ul style="list-style-type: none"> ▶ Check to ensure the load is evenly distributed, and that the shaker is level on a solid surface ▶ Restart by pressing the START/STOP button
	<ul style="list-style-type: none"> • Fuse(s) burned out 	<ul style="list-style-type: none"> ▶ Replace
	<ul style="list-style-type: none"> • Fuse may not be seated properly 	<ul style="list-style-type: none"> ▶ Remove and reinstall the fuse carefully
	<ul style="list-style-type: none"> • Shaking speed has been set to zero by program running or by computer interface 	<ul style="list-style-type: none"> ▶ Reset shaking speed
	<ul style="list-style-type: none"> • Defective main board • Defective display controller board • Defective motor • Drive belt out of alignment or worn 	<ul style="list-style-type: none"> ▶ Call for service
	<ul style="list-style-type: none"> • Jammed shaking mechanism 	<ul style="list-style-type: none"> ▶ Check for debris ▶ Clean ▶ Call for service if necessary
Shaker runs slowly and/or no speed indication	<ul style="list-style-type: none"> • Fuse may not be seated properly 	<ul style="list-style-type: none"> ▶ Remove and reinstall the fuse carefully.
	<ul style="list-style-type: none"> • Incorrect speed calibration 	<ul style="list-style-type: none"> ▶ Reset shaking speed (see <i>Speed calibration on p. 27</i>)
	<ul style="list-style-type: none"> • Defective main board • Defective motor • Drive belt out of alignment or worn 	<ul style="list-style-type: none"> ▶ Call for service

Symptom	Cause	Solution
Shaker does not run at set speed	<ul style="list-style-type: none"> • Shaker is overloaded and/or you are using baffled flasks 	▶ Remove some contents and balance load
	<ul style="list-style-type: none"> • Defective motor • Drive belt out of alignment or worn 	▶ Call for service
Operating noise	<ul style="list-style-type: none"> • Load out of balance 	▶ Unload all contents and reload
	<ul style="list-style-type: none"> • Loose component(s) in platform, subplatform and/or drive assembly 	▶ Call for service
Unit does not reach set temperature	<ul style="list-style-type: none"> • Heater fuse blown 	▶ Replace
	<ul style="list-style-type: none"> • Compressor fuse blown 	▶ Replace
	<ul style="list-style-type: none"> • Compressor over-pressure switch activated • Defective refrigeration system • Defective heater 	▶ Call for service
	<ul style="list-style-type: none"> • Ambient temperature too high or too low 	▶ Cool or heat the room as needed
	<ul style="list-style-type: none"> • Incorrect temperature indication 	▶ See <i>Incorrect temperature indication</i> section of this table
Incorrect temperature indication	<ul style="list-style-type: none"> • Defective RTD assembly • Defective main board 	▶ Call for service
	<ul style="list-style-type: none"> • Incorrect temperature calibration 	• (see <i>Temperature offset calibration on p. 26</i>)

Troubleshooting

New Brunswick™ I24/24R Benchtop Incubator Shaker
English (EN)

7 Maintenance

7.1 Routine maintenance



WARNING!

- ▶ When cleaning the unit, always turn off the shaker and disconnect the power cord from the power supply.
-

No routine maintenance schedule is required for the I24/24R.

To ensure that your shaker retains its attractive appearance, an occasional cleaning, using a cloth with conventional household (non-abrasive) cleaner is recommended (see section below for more details).

We also suggest that the area around the shaker be vacuumed or swept to remove dust and other debris, ensuring proper air flow in and around the shaker.

7.2 Cleaning external & internal surfaces

The unit may be cleaned using a damp cloth or any standard household or laboratory cleaner to wipe down its outer surfaces. Do not use abrasive or corrosive compounds to clean this instrument, as they may damage the unit.

If Biohazard decontamination is required, see the following section.

7.3 Biohazard decontamination

It is the responsibility of the user to carry out appropriate decontamination procedures if hazardous material is spilled on or inside the equipment. Before using any cleaning or decontamination method other than those suggested by the manufacturer, users should check with Eppendorf that the proposed method would not damage the equipment.

Commercially available household bleach solutions, when diluted at a 1:10 ratio, are effective in routine decontamination of the instrument. The method for decontaminating a spill depends upon the nature of the spill.

Spills involving fresh cultures or samples known to have low concentrations of biomass should be flooded with decontamination solution and soaked for 5 min before cleanup. Spills involving samples with high concentrations of biomass, or involving organic matter, or occurring in areas warmer than room ambient temperature, should be exposed to decontamination solution for *at least one hour* before cleanup.

**WARNING!**

- ▶ Personnel involved in the cleanup of any spill should wear gloves, safety glasses, and a laboratory coat or gown during the cleanup process. Respiratory protection should be considered for spills where aerosolization is suspected.
-

8 Technical data

8.1 Specifications

These specifications assume a maximum load of 15.5 kg (34 lb), including platforms, clamps, glassware and contents.

Shaking	
Speed	• 25 – 500 rpm
Control accuracy	• ±1 rpm
Indication	• Displayed in 1 rpm increments
Stroke/orbit	• 1.9 cm (¾ in) or 2.5 cm (1 in)
Temperature	
Range (I24)²	• 5 °C above ambient temperature to 60 °C
Range (24R)²	• 15 °C below ambient temperature (minimum 4 °C) to 60 °C
Control accuracy	• ±0.1 °C at 37 °C
Indication	• Displayed in 0.1 °C increments
Heaters	• Long-life, low-watt density resistance-type heater with high temperature thermostat
Dimensions and weight	
Width	• 55.8 cm (22 in)
Depth	• Front to back: 76.2 cm (30 in)
Height	• 61.1 cm (24 1/16 in) • With lid open: 101.9 cm (40 1/8 in)
Chamber width	• 51.7 cm (20 3/8 in)
Chamber depth	• 53.3 cm (21 in)
Chamber height	• 34.4 cm (13 9/16 in)
Platform width	• 46 cm (18 in)
Platform depth	• 46 cm (18 in)
Weight	• 24 weight: 62.7 kg (138 lbs) • 24R weight: 83.6 kg (184 lbs)
Altitude limit	• 2000 m
Alarms	• Visible and audible warning indication when speed deviates more than 5 rpm or temperature more than 1°C from setpoints, and when timer has expired. Audible alarm can be muted
LED display	• 1.4 cm (9/16 in)
RS-232	• Data logging
Setpoint retention	• All setpoints and operating status are retained in non-volatile memory

Technical data

New Brunswick™ I24/24R Benchtop Incubator Shaker
English (EN)

Automatic restart	<ul style="list-style-type: none"> • Automatic restart after power is restored, indicated by flashing display 	
Drive	<ul style="list-style-type: none"> • Triple eccentric counterbalanced drive with nine permanently lubricated ball bearings 	
Drive motor	<ul style="list-style-type: none"> • Solid-state brushless DC motor 	
Safety	<ul style="list-style-type: none"> • Independent mechanical sensing <i>tilt switch</i> shuts off the motor in an unbalanced condition • Drive Interrupt shuts off power to shaker when door opens • Acceleration/deceleration circuit prevents sudden starts and stops, minimizing both splashing and mechanical damage 	
Electrical requirements	<ul style="list-style-type: none"> • 120 V, 60 Hz 	I24: 800 VA per shaker 24R: 1500 VA per shaker
ETL regulatory standards	<ul style="list-style-type: none"> • UL61010A-1 • UL61010A-2-010 	<ul style="list-style-type: none"> • CAN/CSA-C22.2 No 1010.1 • CAN/CSA-C22.2 No 1010.2.010

9 Ordering information

9.1 Accessories

When ordering accessories, you may be asked to provide the model number and serial number of your shaker. This information is on the electrical specification plate, located on the rear panel of the unit.

9.2 Platforms

Tab. 9-1: Available platforms

Description	Capacity	Part No.
Universal platform	See table below	M1250-9902
125 ml Erlenmeyer flask Dedicated Platform*	34	M1194-9904
250 ml Erlenmeyer flask Dedicated Platform*	25	M1194-9905
500 ml Erlenmeyer flask Dedicated Platform*	16	M1194-9906
1 L Erlenmeyer flask Dedicated Platform*	9	M1194-9907
2 L Erlenmeyer flask Dedicated Platform*	5	M1194-9908
2.8 L Fernback flask Dedicated Platform*	4	M1194-9932
Utility carrier with cushioned crossbars	-	M1194-9909
Utility tray with non-skid rubber surface	-	M1194-9910
Sticky pad platform	-	M1250-9903

*Dedicated Platforms include flask clamps

Should you decide in favor of the Universal Platform, following is a list of that particular platform's flask capacity, according to flask size:

Ordering information

New Brunswick™ I24/24R Benchtop Incubator Shaker
English (EN)

Tab. 9-2: Universal Platform flask capacities

Flask type	Capacity*
50 ml Erlenmeyer flasks	45
125 ml Erlenmeyer flasks	21
250 ml Erlenmeyer flasks	18
500 ml Erlenmeyer flasks	14
1 L Erlenmeyer flasks	8
2 L Erlenmeyer flasks	5
2.8 L Erlenmeyer flasks	4

*Clamps for Universal Platform are sold separately

9.3 Flask clamps for Universal Platforms

The following clamps, according to flask size, are available for use with the Universal Platform:

Clamp size	Part number
10 ml Erlenmeyer flask	ACE-10S
25 ml Erlenmeyer flask	M1190-9004
50 ml Erlenmeyer flask	M1190-9000
125 ml Erlenmeyer flask	M1190-9001
250 ml Erlenmeyer flask	M1190-9002
500 ml Erlenmeyer flask	M1190-9003
1 L Erlenmeyer flask	ACE-1000S
2 L Erlenmeyer flask	ACE-2000S
2.8 L Erlenmeyer flask	ACSB-2800S

9.4 Replacement clamp hardware kits

Eppendorf flask clamps come complete with mounting screws. Additional screws are available separately in packs of 25.

9.5 Test tube racks & other accessories

Tab. 9-3: Racks & trays

Accessory description	Part number	Platform capacity	
Adjustable angle test tube rack for tubes 8 – 11 mm diameter	80 tube capacity	M1289-0100	7
	60 tube capacity	M1289-0010	9
	48 tube capacity	M1289-0001	9
Adjustable angle test tube rack for tubes 12 - 15 mm diameter	60 tube capacity	M1289-0200	7
	44 tube capacity	M1289-0020	9
	34 tube capacity	M1289-0002	9
Adjustable angle test tube rack for tubes 15 – 18 mm diameter	42 tube capacity	M1289-0300	7
	31 tube capacity	M1289-0030	9
	24 tube capacity	M1289-0003	9
Adjustable angle test tube rack for tubes 18 – 21 mm diameter	30 tube capacity	M1289-0400	7
	23 tube capacity	M1289-0040	9
	18 tube capacity	M1289-0004	9
Adjustable angle test tube rack for tubes 22 – 26 mm diameter	22 tube capacity	M1289-0500	7
	16 tube capacity	M1289-0050	9
	13 tube capacity	M1289-0005	9
Adjustable angle test tube rack for tubes 26 - 30 mm diameter	20 tube capacity	M1289-0600	7
	16 tube capacity	M1289-0060	9
	12 tube capacity	M1289-0006	9
Microplate holder rack (stacked)	3 deep well or 9 standard	M1289-0700	16
Microplate holder rack (single layer)	5 deep well or standard	TTR-221	4
Angled test tube rack holder* for user-supplied test tube racks that are 4-5 in. (10-13 mm) wide and up to 38 mm (15 in) long	TTR-210		4
Angled test tube rack spacer bar* for use with TTR-210 to accommodate test tubes racks that are less than 13 mm (5 in) wide	TTR-215		NA

* Universal platform required

9.6 Remote alarm option

The I24/24R shakers can be equipped with a factory-installed alarm component (part number M1320-8029). When it is hooked up to your relay and receiving equipment, this device will send notification of an alarm condition to the remote location you choose.

Ordering information

New Brunswick™ I24/24R Benchtop Incubator Shaker
English (EN)

10 Transport, storage and disposal

10.1 Disposal

In case the product is to be disposed of, the relevant legal regulations are to be observed.

Information on the disposal of electrical and electronic devices in the European Community:

Within the European Community, the disposal of electrical devices is regulated by national regulations based on EU Directive 2012/19/EU pertaining to waste electrical and electronic equipment (WEEE).

According to these regulations, any devices supplied after August 13, 2005, in the business-to-business sphere, to which this product is assigned, may no longer be disposed of in municipal or domestic waste. To document this, they have been marked with the following identification:



Because disposal regulations may differ from one country to another within the EU, please contact your supplier if necessary.

In Germany, this is mandatory from March 23, 2006. From this date, the manufacturer has to offer a suitable method of return for all devices supplied after August 13, 2005. For all devices supplied before August 13, 2005, the last user is responsible for the correct disposal.

Index

New Brunswick™ I24/24R Benchtop Incubator Shaker
English (EN)

Index**A**

Accessories.....	37, 39
Actual temperature.....	26, 26
Alarm	35
Alarm functions	25
Alarms	9
Audible alarm: disabling the	25
Audible alarm: muting the.....	25

B

Biohazards.....	34
-----------------	----

C

Calibrate speed.....	27
Checking setpoints	24
Clamp hardware kits.....	38
Cleaning	33
Continuous operation	9
Continuous run.....	24

D

Danger level	5
CAUTION	5
DANGER.....	5
NOTICE	5
WARNING	5
Decontamination	34
Dimensions.....	35
Disposal.....	41
Double girdle clamps	19

E

Electrical connections	21
Electrical requirements	16, 36

Electrical service.....	21
Environment	16

F

Flask capacities.....	37
Flask clamp installation	19
Flask clamps	38
Function indicators.....	13

I

Incomplete order	15
Indicated temperature	26, 26
Inspection of boxes.....	15
Installation space	16

L

LED display.....	12
------------------	----

M

Maintenance	33
Manual conventions.....	6
Missing parts	15
Mute function	25

O

On/off switch: location of.....	23
Operation	23
Operation mode	9

P

Packing list.....	15
Platform: available types.....	37
Platforms.....	9
Power failure.....	27

R

Refrigeration schematic14
Remote alarm option 13, 39

S

Safety switch9
Shipping damage15
Space requirements.....16
Specifications35
Spills34
Starting the unit23
Status indicators.....12
Symbols used6

T

Temperature correction value26
Temperature offset calibration26
Temperature setpoint26
Timed functions.....25
Timed run9
Triple eccentric drive9
Troubleshooting29

U

Universal platform37
Untimed run24
User interface keys.....11
Using this manual5

V

Visual alarm: disabling the.....25

W

Weight35

Index

New Brunswick™ I24/24R Benchtop Incubator Shaker
English (EN)

Evaluate your manual

Give us your feedback.
www.eppendorf.com/manualfeedback