

# E2M0.7, E2M1 and E2M1.5 Rotary Vacuum Pumps

## INSTRUCTION MANUAL

edwardsvacuum.com



DESCRIPTION	ITEM NUMBER
E2M0.7 (0.7 m <sup>3</sup> h <sup>-1</sup> ), 200-230 V, 50/60Hz	A37141919
E2M0.7 (0.7 m <sup>3</sup> h <sup>-1</sup> ), 100-120 V, 50/60 Hz	A37141902
E2M1.5 (1.5 m <sup>3</sup> h <sup>-1</sup> ), 200-230 V, 50/60 Hz	A37132919
E2M1.5 (1.5 m <sup>3</sup> h <sup>-1</sup> ), 200-230 V, 50/60 Hz (Interstage)	A37104919
E2M1.5 (1.5 m <sup>3</sup> h <sup>-1</sup> ), 100-120 V, 50/60 Hz	A37132902
E2M1.5 (1.5 m <sup>3</sup> h <sup>-1</sup> ), 100-120 V, 50/60 Hz (Interstage)	A37104902
E2M1 (1.0 ft <sup>3</sup> min <sup>-1</sup> ), 200-230 V, 50/60 Hz	A37233919
E2M1 (1.0 ft <sup>3</sup> min <sup>-1</sup> ), 100-120 V, 50/60 Hz	A37233902

## Copyright notice

©Edwards Limited 2020. All rights reserved.

## Associated publications

<b>Publication title</b>	<b>Publication number</b>
Vacuum pump and vacuum system safety	P40040100

## Trademark credit

Edwards and the Edwards logo are trademarks of Edwards Limited, Innovation Drive, Burgess Hill, West Sussex RH15 9TW.

## Disclaimer

The content of this manual may change from time to time without notice. We accept no liability for any errors that may appear in this manual nor do we make any expressed or implied warranties regarding the content. As far as practical we have ensured that the products have been designed and constructed to be safe and without risks when properly installed and used in accordance with their operating instructions.

We accept no liability for loss of profit, loss of market or any other indirect or consequential loss whatsoever.

Product warranty and limit of liability are dealt with in our standard terms and conditions of sale or negotiated contract under which this document is supplied.

You must use this product as described in this manual. Read the manual before you install, operate, or maintain the product.

## CE Declaration of Conformity

Edwards Ltd  
Innovation Drive  
Burgess Hill  
West Sussex  
RH15 9TW  
UK

The following product

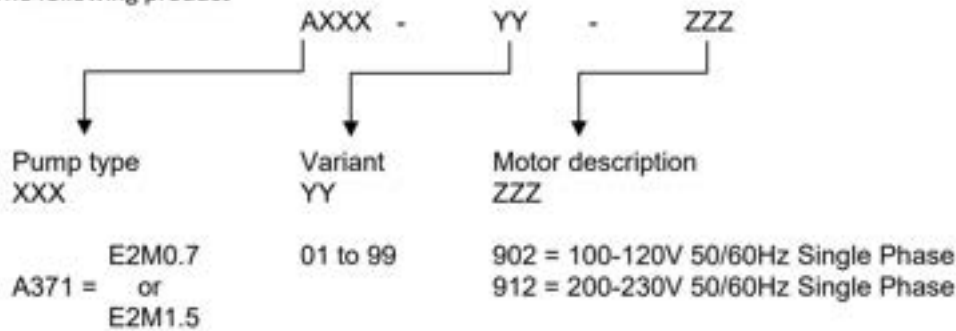

Is in conformity with the relevant requirements of European CE legislation:

2006/42/EC	Machinery directive
2014/34/EU	ATEX directive on use in potentially explosive atmospheres. Intertek Testing and Certification Limited, 0359 Intertek House, Cleeve Road, Leatherhead, Surrey, KT22 7SB
ATEX marking:	 II 3 G Ex h IIB T4 Gc INTERNAL ATMOSPHERES ONLY TCF 218
2011/65/EU	Restriction of certain hazardous substances (RoHS) directive as amended by Delegated Directive (EU) 2015/863

Based on the relevant requirements of harmonised standards:

EN 1012-2:1996 +A1:2009	Compressors and vacuum pumps. Safety requirements. Vacuum pumps
EN 61010-1:2010	Safety requirements for electrical equipment for measurement, control and laboratory use. General requirements
EN ISO 80079-36:2016	Explosive atmospheres – Part 36: Non-electrical equipment for explosive atmospheres. Basic method and requirements
EN ISO 80079-37:2016	Explosive atmospheres - Part 37: Non-electrical equipment for explosive atmospheres -- Non-electrical type of protection constructional safety "c", control of ignition sources "b", liquid immersion "k"

Documentation Officer: Jelena Havelkova, Spielberk Office Centre, Holandska 10, Brno, 63900 Czech Republic,  
☎: +42(0) 734 418 896, ✉: documentation@edwardsvacuum.com

This declaration, based on the requirements of the listed Directives and EN ISO/IEC 17050-1, covers all product serial numbers from this date on: 21<sup>st</sup> May 2020.

Petr Smerek – Engineering Manager  
Scientific Vacuum Division  
Lutín, CZ

Nina Buta – General Manager  
Lutín, CZ



# Additional Legislation and Compliance Information

## EU RoHS Directive: Material Exemption Information

This product is compliant with the following Annex III Exemptions

- 6(b) **Lead** as an alloying element in aluminium containing up to 0.4% by weight
- 6(c) Copper alloy containing up to 4% **lead** by weight

## EU REACH Regulation Compliance

This product is a complex article which is not designed for intentional substance release. To the best of our knowledge the materials used comply with the requirements of REACH. The product manual provides information and instruction to ensure the safe storage, use, maintenance and disposal of the product including any substance based requirements.

## Article 33.1 Declaration

This product does contain Candidate List Substances of Very High Concern above 0.1%ww by article as clarified under the 2015 European Court of Justice ruling in case C-106/14.

- Lead (Pb) added to the Candidate List June 2018

As indicated by the applied RoHS exemption(s) above this substance is present in certain aluminium and brass components.

### ADDITIONAL INFORMATION

The products listed are also in scope for and comply with the requirements of the following:

2012/19/EU	Directive on waste electrical and electronic equipment (WEEE)
CSA-C22.2 No.77-2014	Motors with inherent overheating protection
CSA-C22.2 No.100-2014	Motors and generators
Product is certified to CSA-C22.2 No.61010-1-12	Safety requirements for electrical equipment for measurement, control and laboratory use – Part 1: General requirements
Product conforms to UL61010-1 3 <sup>rd</sup> Edition	Safety requirements for electrical equipment for measurement, control and laboratory use – Part 1: General requirements

### 材料成分声明

### China Material Content Declaration

部件名称 Part name	有害物质 Hazardous Substances					
	铅 Lead (Pb)	汞 Mercury (Hg)	镉 Cadmium (Cd)	六价铬 Hexavalent Chromium (Cr VI)	多溴联苯 Polybrominated biphenyls (PBB)	多溴二苯醚 Polybrominated diphenyl ethers (PBDE)
铸铝及铝合金制品 Aluminium alloys	X	O	O	O	O	O
铜接头 Brass connectors	X	O	O	O	O	O

O: 表示该有害物质在该部件的所有均质材料中的含量低于 GB/T 26572 标准规定的限量要求。  
O: Indicates that the hazardous substance contained in all of the homogeneous materials for this part is below the limit requirement in GB/T 26572.

X: 表示该有害物质在该部件的至少一种均质材料中的含量超出 GB/T26572 标准规定的限量要求。  
X: Indicates that the hazardous substance contained in at least one of the homogeneous materials used for this part is above the limit requirement of GB/T26572.

# Contents

<b>1. Safety and compliance.</b> . . . . .	<b>7</b>
1.1 Definition of Warnings and Cautions. . . . .	7
1.2 Safety symbols. . . . .	7
<b>2. Introduction.</b> . . . . .	<b>9</b>
2.1 Scope and definitions. . . . .	9
2.2 ATEX directive implications. . . . .	9
2.3 Description. . . . .	9
2.4 Gas-ballast. . . . .	11
<b>3. Technical data.</b> . . . . .	<b>12</b>
3.1 Operating and storage conditions. . . . .	12
3.2 Performance. . . . .	12
3.3 Mechanical data. . . . .	13
3.4 Lubrication data. . . . .	14
3.5 Electrical data. . . . .	14
3.5.1 Electrical cables. . . . .	15
<b>4. Installation.</b> . . . . .	<b>17</b>
4.1 Safety. . . . .	17
4.2 System design. . . . .	17
4.3 Unpack and inspect. . . . .	18
4.4 Locate the pump. . . . .	18
4.5 Fill the pump with oil. . . . .	19
4.6 Electrical installation. . . . .	19
4.6.1 Connect the pump to the electrical supply. . . . .	19
4.6.2 Check the direction of rotation. . . . .	20
4.7 Inlet-port connection. . . . .	20
4.7.1 General requirements. . . . .	20
4.7.2 Side inlet-port connection. . . . .	21
4.8 Pump outlet connection. . . . .	21
4.9 Leak-test the system. . . . .	21
<b>5. Operation.</b> . . . . .	<b>22</b>
5.1 ATEX directive implications. . . . .	22
5.1.1 Flammable/pyrophoric materials. . . . .	22
5.1.2 Gas purges. . . . .	23
5.2 Gas-ballast control. . . . .	23
5.3 Start-up. . . . .	24
5.4 To achieve ultimate vacuum. . . . .	24

5.5 To pump condensable vapours. ....	25
5.6 To decontaminate the oil. ....	25
5.7 Unattended operation. ....	25
5.8 Shut-down. ....	25
<b>6. Maintenance. ....</b>	<b>27</b>
6.1 Safety information. ....	27
6.2 Maintenance plan. ....	27
6.3 Check the oil level. ....	28
6.4 Replace the oil. ....	29
6.5 Inspect and clean the inlet-filter. ....	29
6.6 Clean or replace the gas-ballast O-ring. ....	30
6.7 Clean the motor fan-cover and enclosure. ....	31
6.8 Clean and overhaul the pump. ....	31
6.9 Fit new blades. ....	31
6.10 Replace the capacitor and test the motor. ....	31
<b>7. Fault finding. ....</b>	<b>32</b>
7.1 The pump has failed to start. ....	32
7.2 The pump fails to achieve specified performance (failure to reach ultimate vacuum). ....	32
7.3 The pump is noisy. ....	32
7.4 The pump surface temperature is above 100 °C. ....	32
7.5 The vacuum is not maintained after the pump is switched off. ....	33
7.6 The pumping speed is poor. ....	33
7.7 There is an external oil leak. ....	33
<b>8. Storage. ....</b>	<b>34</b>
<b>9. Disposal. ....</b>	<b>35</b>
<b>10. Spares and accessories. ....</b>	<b>36</b>
10.1 Spares. ....	36
10.2 Accessories. ....	36
10.2.1 Inlet catchpot. ....	37
10.2.2 Inlet dust filter. ....	37
10.2.3 Inlet desiccant trap. ....	37
10.2.4 Inlet chemical trap. ....	38
10.2.5 Solenoid operated gas-ballast control valve. ....	38
10.2.6 Foreline trap. ....	38
10.2.7 Solenoid operated pipeline valve. ....	38
10.2.8 Outlet mist filter. ....	38
10.2.9 Oil drain extension. ....	38
10.2.10 Vibration isolators. ....	39

10.2.11 Pump inlet or outlet NW25 adaptor. ....	39
<b>11. Service. ....</b>	<b>40</b>
11.1 Return the equipment or components for service .....	40



## List of Figures

Figure 1: General view of the pump. ....	11
Figure 2: Dimensions mm (inches). ....	14
Figure 3: Inlet-filter removal and replacement. ....	30
Figure 4: Gas-ballast O-ring removal and replacement. ....	31
Figure 5: Accessories. ....	37



# 1. Safety and compliance

## 1.1 Definition of Warnings and Cautions

### NOTICE:



This manual meets our obligation to provide you with information. For safe operation from the start, read these instructions carefully before you install or commission the equipment.

Read all the safety instructions in this section and the rest of this manual carefully and make sure that you obey these instructions. The equipment must only be operated and maintained by trained personnel in the proper condition and as described in this instruction manual.

Obey local and state requirements and regulations. If you have any questions about safety, operation or maintenance of the device, please contact our nearest subsidiary.

Important safety information is highlighted as warning and caution instructions. Obey these instructions.



### WARNING:

If you do not obey a warning, there is a risk of injury or death. Different symbols are used according to the type of hazard.



### CAUTION:

If you do not obey a caution, there is a risk of minor injury, damage to equipment, related equipment or process.



### NOTICE:

Information about properties or instructions for an action which, if ignored, will cause damage to the pump or the system.





We reserve the right to change the design and the stated data. The illustrations are not binding.

Keep the instructions for future use.

## 1.2 Safety symbols

The safety symbols on the products shows the areas where care and attention is necessary.

The safety symbols that follow are used on the product or in the product documentation.

	<p>Warning/Caution A safety instruction which must be followed.</p>
	<p>Warning - Dangerous voltage Identifies possible hazards from dangerous voltages.</p>
	<p>Warning - Hot surfaces Identifies a potential hazard from a hot surface.</p>
	<p>Warning - Use protective equipment Use appropriate protective equipment.</p>
	<p>Warning - Risk of explosion An indication that there is a risk of explosion when you do the task.</p>

## 2. Introduction

### 2.1 Scope and definitions

This manual provides installation, operation and maintenance instructions for our rotary vacuum pumps. The pump must be used as specified in this manual. Read this manual before installing and operating the pump.

### 2.2 ATEX directive implications



This equipment is designed to meet the requirements of Group II Category 3 equipment in accordance with Directive 2014/34/EU of the European Parliament and the Council of 26th February 2014 on the approximation of the laws of the Member States concerning equipment and protective systems intended for use in potentially explosive atmospheres. (The ATEX Directive).

The ATEX Category 3 applies in respect of potential ignition sources internal to the equipment. An ATEX Category has not been assigned in respect of potential ignition sources on the outside of the equipment as the equipment has not been designed for use where there is an external potentially explosive atmosphere. There is no potential source of ignition within the pump during normal operation but there may be potential sources of ignition under conditions of predictable and rare malfunction as defined in the Directive.

There is no potential source of ignition within the pump during normal operation but there may be potential sources of ignition under conditions of predictable and rare malfunction as defined in the Directive. Accordingly, although the pump is designed to pump flammable materials and mixtures, operating procedures should ensure that under all normal and reasonably predictable conditions, these materials and mixtures are not within explosive limits. Category 3 is considered appropriate for the avoidance of ignition in the case of a rare malfunction which allows flammable materials or mixtures to pass through the pump while within their explosive limits.

When flammable or pyrophoric materials are present within the equipment:

- Do not allow air to enter the equipment.
- Ensure that the system is leak tight.

For further information, please contact us: refer to our website [www.edwardsvacuum.com](http://www.edwardsvacuum.com) for details of your nearest company.

### 2.3 Description

The pump is shown in *Figure: General view of the pump on page 11.*

Refer to [Figure: General view of the pump on page 11](#) for item numbers in brackets in the following descriptions.

The pumps are two-stage, direct drive, sliding vane pumps. The pump is oil-sealed and designed for reliable, long-term operation. The pump is a free-standing unit. The drive is provided through an Oldham coupling by a single-phase motor.

The motor is totally enclosed and is cooled by the motor-cooling fan which directs air along the motor fins. The motor is fitted with a thermal overload device. When the motor is too hot, the thermal overload device switches off the pump. The thermal overload device has an automatic reset, when the motor cools down, the device resets and the motor will restart.

An oil pressure system lubricates the pump shaft bearing surfaces and rotor sealing faces. The pump has an oil distribution valve which prevents discharge of oil to the pump interior (suckback) after the pump stops. The pumping chambers are air-tight, so this arrangement prevents oil suckback unless the gas-ballast valve is open. For protection in this case, refer to [Gas-ballast on page 11](#).

Inspect the level and condition of oil in the oil box reservoir through the sight-glass. An oil filler-plug is fitted to the top of the oil box. An oil drain-plug is fitted at the bottom of the oil box.

The pump has a carrying handle, inlet-port, outlet nozzle and gas-ballast control. The pump is mounted on a steel baseplate on rubber pads. Details of suitable vibration isolators and other recommended accessories are given in [Accessories on page 36](#).



Figure 1 General view of the pump

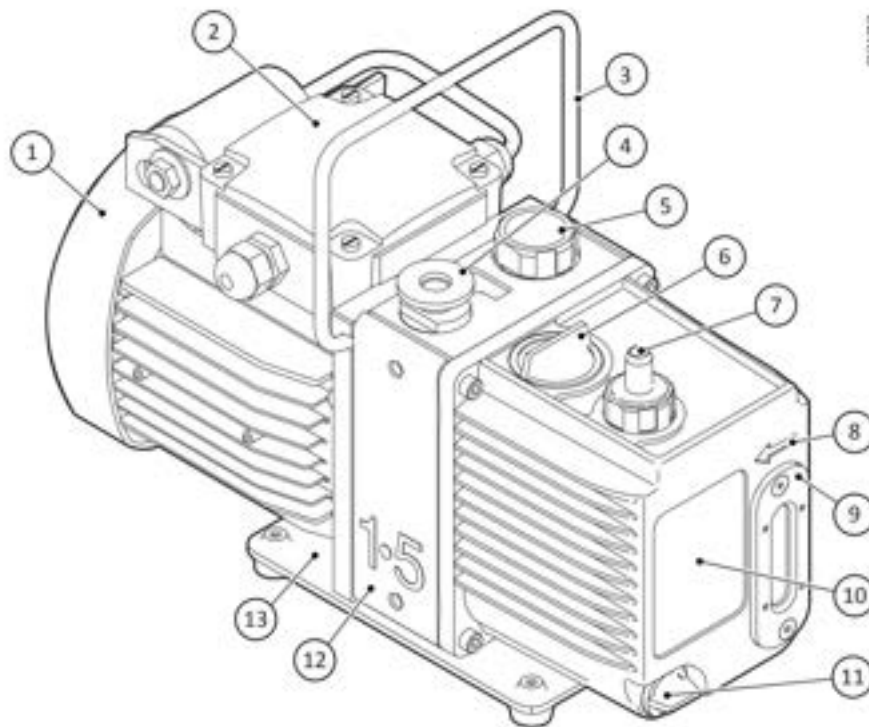

- |   |                                     |
|---|-------------------------------------|
| 1. Fan cover  | 2. Motor terminal box               |
| 3. Handle (can be removed: see <a href="#">Locate the pump on page 18</a> ) | 4. NW10 inlet-port (adaptor flange) |
| 6. Oil filler-plug  | 5. Gas-ballast control              |
| 8. Pump/motor shaft rotation direction arrow                                | 7. Outlet nozzle                    |
| 11. Oil drain-plug  | 9. Oil sight-glass and bezel        |
| 13. Baseplate   | 10. Pump identification label       |
|   | 12. Removable side panel            |

## 2.4 Gas-ballast

To pump high vapour loads, gas-ballast is delivered into the pump to prevent condensation of the vapour carried by the pumped gases.

Air (or another gas) can be introduced into the low vacuum stage through the gas-ballast control. The gas-ballast control is a multi-turn valve which can be adjusted, as required, between closed and fully open.

### 3. Technical data

#### 3.1 Operating and storage conditions

Table 1 Operating and storage conditions

Parameter	Reference data
Ambient temperature range (operation)	12 to 40 °C (53.6 to 104 °F)
Ambient temperature range (storage)	- 30 to 70 °C (-22 to 158 °F)
Normal surface temperature of the pump-body*	50 to 70 °C (122 to 158 °F)
Maximum humidity (operation)	90% RH
Maximum altitude (operation)	2000 m (6561 ft)
Pollution degree	2
Installation category	II
Area of use	Indoor

\* At ultimate vacuum, with ambient temperature of 20 °C (68 °F).

#### 3.2 Performance

 Note:

Where total pressures are shown in [Figure: Dimensions \(mm\) on page 14](#), the measurements were taken using an untrapped total pressure capacitance diaphragm gauge on a header, as specified by Pneurop standards.

Table 2 Performance data

Maximum displacement	E2M0.7	E2M1	E2M1.5
50 Hz electrical supply	0.9 m <sup>3</sup> h <sup>-1</sup>	1.0 ft <sup>3</sup> min <sup>-1</sup>	1.8m <sup>3</sup> h <sup>-1</sup>
60 Hz electrical supply	1.1 m <sup>3</sup> h <sup>-1</sup>	1.3 ft <sup>3</sup> min <sup>-1</sup>	2.2m <sup>3</sup> h <sup>-1</sup>
Maximum pumping speed - Pneurop			
50 Hz electrical supply	0.75 m <sup>3</sup> h <sup>-1</sup>	0.94 ft <sup>3</sup> min <sup>-1</sup>	1.6m <sup>3</sup> h <sup>-1</sup>
60 Hz electrical supply	0.95 m <sup>3</sup> h <sup>-1</sup>	1.2 ft <sup>3</sup> min <sup>-1</sup>	2.0m <sup>3</sup> h <sup>-1</sup>
Motor rotational speed			
50 Hz electrical supply	1400 r min <sup>-1</sup>	2800 r min <sup>-1</sup>	2800 r min <sup>-1</sup>
60 Hz electrical supply	1700 r min <sup>-1</sup>	3400 r min <sup>-1</sup>	3400 r min <sup>-1</sup>
Ultimate vacuum			
without gas-ballast (partial pressure)	7 x 10 <sup>-4</sup> mbar (7 x 10 <sup>-2</sup> Pa)	3.8 x 10 <sup>-4</sup> torr (5 x 10 <sup>-2</sup> Pa)	5 x 10 <sup>-4</sup> mbar (5 x 10 <sup>-2</sup> Pa)
without gas-ballast (total pressure)	3 x 10 <sup>-3</sup> mbar (3 x 10 <sup>-1</sup> Pa)	1.1 x 10 <sup>-3</sup> torr (1.5 x 10 <sup>-1</sup> Pa)	1.5 x 10 <sup>-3</sup> mbar (1.5 x 10 <sup>-1</sup> Pa)

Maximum displacement	E2M0.7	E2M1	E2M1.5
with full gas-ballast (partial pressure)	$2 \times 10^{-1}$ mbar ( $2 \times 10^{-1}$ Pa)	$1.9 \times 10^{-2}$ torr (2.5 Pa)	$2.5 \times 10^{-2}$ mbar (2.5 Pa)
Maximum water vapour inlet pressure	15 mbar	11.3 torr	15 mbar
Maximum water vapour pumping rate	$8 \text{ g h}^{-1}$	$16 \text{ g h}^{-1}$	$16 \text{ g h}^{-1}$
Maximum permitted outlet pressure (for full pump throughout)	0.5 bar gauge 1.5 bar absolute ( $1.5 \times 10^5$ Pa)	0.5 bar gauge 1.5 bar absolute ( $1.5 \times 10^5$ Pa)	0.5 bar gauge 1.5 bar absolute ( $1.5 \times 10^5$ Pa)

### 3.3 Mechanical data

*Table 3 Mechanical data*

Parameter	Data
Approximate pump mass	10 kg (22 lbs)
Dimensions	Refer to <i>Figure: Dimensions (mm) on page 14</i>
Degree of protection	IP44
Pump inlet port	NW10 (the flange can be removed from the 3/8 inch BSP tapped hole)
Pump outlet port	11 mm external diameter nozzle (the nozzle can be removed from the 3/8 inch BSP tapped hole)
Noise level at 1 metre	54 dB (A)

Figure 2 Dimensions mm (inches)

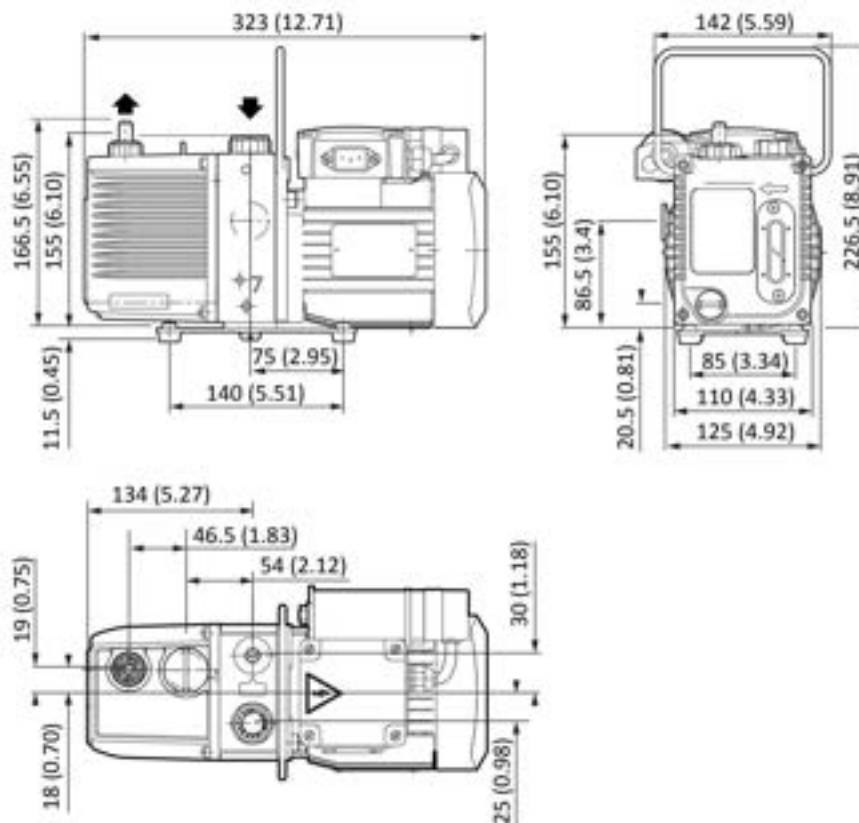

### 3.4 Lubrication data

**Note:**

A Material Safety Data Sheet for Ultragrade 15 is available on request.

Table 4 Lubrication data

Recommended oil*	Ultragrade 15
Maximum oil capacity	0.32 litre

\* To operate the pump when the ambient temperature is outside the range specified in [Operating and storage conditions on page 12](#), or to optimise pump performance when processing condensable vapours, a different oil may be required.

### 3.5 Electrical data

The motor start-up current is drawn for less than one second. Use time-lag fuses to prevent unnecessary fuse failure when the pump starts. If the pump is used at temperatures lower than 12 °C (53.6 °F), the start-up current will be drawn for longer, this may cause the motor thermal overload device to open.

<b>E2M0.7 pump</b>	
Motor output rating - continuous	0.09 kW
Motor electrical supply	Single phase
<b>E2M1 and E2M1.5 pumps</b>	



Motor output rating - continuous	0.16 kW
Motor electrical supply	Single phase

Table 5 Electrical data

Pump	Nominal supply (V)	Frequency (Hz)	Full load current (A)
E2M0.7	100 - 115	50	1.8
	100 - 120	60	1.9
	200 - 230	50	0.85
	200 - 240	60	1.0
E2M1 and E2M1.5	100 - 115	50	3.1
	100 - 120	60	3.0
	200 - 230	50	1.3
	200 - 230	60	1.4

Table 6 Recommended regional supply protection

Area	Voltage (V)	Rating (A)
UK	230	6
Europe	230	6
USA	110	10
Japan	100	10

### 3.5.1 Electrical cables

Recommended cord sets and fuses for regional requirements.

Table 7 Recommended cord sets

Description	Rating	Coupler type	Item number
Cord set assembly, UK	Cable style = H05VV-F, 3 x 1.0 mm <sup>2</sup> , 300 V, 70 °C, maximum length of 2.0 metres Plug type = BS1363 UK plug Appliance coupler = IEC60320 style C14 Fuse type = BS1363 10 Amp fuse, to an IEC60320 style	Straight entry	A50505000
Cord set assembly, Europe	Cable style = H05VV-F, 3 x 1.0 mm <sup>2</sup> , 300 V, 70 °C, maximum length of 2.0 metres Plug type = European Schuko VDE approved, 16 A 250 V rated with dual earthing contact Appliance coupler = IEC60320 style C14	Straight entry	A50506000

## A37132880\_F - Technical data

Description	Rating	Coupler type	Item number
Cord set assembly, USA/ Canada (200-230 V)	Cable style = SJT, 3 x 14 AWG, 300 V, 90 °C, VW-1 maximum length of 3.0 metres Plug type = NEMA, 6-15P plug Appliance coupler = IEC60320 style C14	-	N/A

## 4. Installation

### 4.1 Safety



**WARNING:**

Ensure that the installation technician is familiar with the safety procedures which relate to the pump oil and the products handled by the pumping system.



**WARNING:**

If a hydrocarbon oil is used in this pump, do not use the pump to process oxygen in concentrations greater than 25% in volume. If the oxygen concentration is greater than 25%, there is a risk of fire or explosion in the oil-box of the pump



**WARNING:**

Do not use the pumps to pump hazardous substances.



**WARNING:**

Obey the safety instructions listed below and take note of appropriate precautions. Failure to do so can cause injury to people and damage to equipment. Prevent any part of the human body from coming into contact with the vacuum.

Ensure that the pump is suitable for your application. If there is any doubt as to the suitability of the pump for your application, refer our guidelines on vacuum pump and vacuum system safety (see the Associated Publication at the end of the contents list at the front of this manual), or contact us for advice.

A suitably trained and supervised technician must install the pump. Obey the safety instructions listed below when installing the pump, especially when connecting the pump into an existing system. Details of specific safety precautions are given at the appropriate point in the instructions.

- Wear the appropriate safety clothing when coming into contact with contaminated components is anticipated. Dismantle and clean contaminated components inside a fume cupboard.
- Vent and purge the vacuum system before starting installation work.
- Take suitable precautions to avoid the inhalation of oil mist and excessive skin contact with pump-oil, as prolonged exposure can be harmful.
- Disconnect the other components in the pumping system from the electrical supply so that they cannot be operated accidentally.
- Safely route any electrical cables so that they cannot accidentally trip people.

### 4.2 System design

Consider the following points when designing the pumping system:

- We recommend the use of a foreline vacuum isolation valve to allow the pump to warm up before pumping condensable vapours or if a vacuum needs to be maintained when the pump is not running.
- Avoid high levels of heat input to the pump from the process gases, otherwise the pump may overheat and seize, and cause the motor thermal overload device to open.
- If using the pump in a high ambient temperature with a high gas throughput, the temperature of the pump body may exceed 70 °C (158 °F). We recommend the use of additional guarding to prevent contact with hot surfaces under these conditions.
- Make sure that the exhaust pipeline cannot become blocked. If an outlet-isolation valve is fitted, make sure the pump cannot be operated with the valve closed.
- Provide for a purge of inert gas when the pumping system is shut down, to dilute dangerous gases to safe concentrations. A suitable gas-ballast control valve for introduction of purge gas into the pump is available as an accessory (refer to [Solenoid operated gas-ballast control valve on page 38](#)).

Contact our application team for further advice on dilution requirements if required.

### 4.3 Unpack and inspect

Remove all packing materials and protective covers and check the pump. If the pump is damaged, notify your supplier and the carrier in writing within three days, state the Item Number of the pump together with your order number and your supplier's invoice number. Retain all packing materials for inspection. Do not use the pump if it is damaged.

Check that your package contains the items listed in [Table: Checklist of items on page 18](#). If any of these items is missing, notify your supplier within three days.

If the pump is not to be used immediately, replace the protective covers. Store the pump in suitable conditions, as described in [Storage on page 34](#).

*Table 8 Checklist of items*

Quantity	Description	Check (✓)
1	Rotary vacuum pump	<input type="checkbox"/>
	Fitting pack containing the following:	
1	Hexagon wrench, 4 mm	<input type="checkbox"/>
1	Hexagon wrench, 6 mm	<input type="checkbox"/>
1	NW10 centring ring	<input type="checkbox"/>
1	O-ring for centring	<input type="checkbox"/>
1	O-ring for outlet port	<input type="checkbox"/>

### 4.4 Locate the pump

The pump can be either free-standing on its baseplate which is fitted with rubber pads, fixed by four fixing bolt holes in the baseplate, or used with vibration isolators. For the location of fixing holes in the baseplate, refer to [Figure: Dimensions \(mm\) on page 14](#). Provide a firm, level platform for the pump. Locate the pump so that the oil level



sight-glass is visible and the oil filler-plug, oil drain-plug, mode selector and gas-ballast control are accessible.

If the pump is part of a permanent installation the handle can be removed to make the pump more compact. To remove the handle, cut the handle into two and remove the free portions from the pump.

If the pump will be located inside an enclosure, ensure that there is adequate ventilation at both ends of the pump, so that the ambient temperature around the pump does not exceed 40 °C. There must be a minimum space of 25 mm between the pump and enclosure walls.

## 4.5 Fill the pump with oil

Fill the pump with oil as described below. Refer to [Figure: General view of the pump on page 11](#) for the item numbers.

1. Remove the oil filler-plug.
2. Pour oil into the pump until the oil-level reaches the MAX mark on the bezel at the top of the oil sight-glass. If the oil-level goes above the MAX mark, remove the oil drain-plug and drain the excess oil from the pump.
3. After a few minutes, recheck the oil-level. If the oil-level is now below the MAX mark, pour more oil into the pump.
4. Refit the oil filler-plug. Tighten the plug firmly by hand. Do not overtighten.

## 4.6 Electrical installation



### WARNING:

Ensure that the electrical installation of the pump conforms with the local and national safety requirements. The pump must be connected to a suitably fused and protected electrical supply with a suitable earth (ground) point, for recommended cord sets refer to [Lubrication data on page 14](#).

### 4.6.1 Connect the pump to the electrical supply

#### Note:

*The pump will restart automatically when the electrical supply is restored after an interruption and when the pump cools after it has overheated. If automatic pump restart is not required, use electric control equipment that must be reset manually.*

1. Insert the moulded IEC connector at the end of the cable into the electrical inlet connector on the motor.
2. Connect the plug (if fitted) at the other end of the cable to the electrical supply. If a plug is not fitted, connect the wires in the cable to the correct terminals of the electrical supply.

## 4.6.2 Check the direction of rotation



### CAUTION:

Ensure that the pump-motor rotates in the correct direction. If it does not, the pump and the vacuum system can become pressurised.

Refer to *Figure: General view of the pump on page 11*.

1. Watch the motor-cooling fan through the fan cover on the end of the motor.
2. Switch on the electrical supply to the motor for a few seconds.
3. Check that the motor-cooling fan rotates in the direction shown by the arrow on the end of the oil box. If the rotation direction is incorrect, immediately switch off the electrical supply and contact us or your supplier for advice.

## 4.7 Inlet-port connection

### 4.7.1 General requirements

To connect the pump to the vacuum system, use either the inlet-port on the top of the pump (*Figure: General view of the pump on page 11*) or the inlet-port on the side of the pump (not shown). To use the side inlet-port, refer to the procedure in *Side inlet-port connection on page 21*.

When using the top or the side inlet-port:

- Connect to the NW10 flange supplied on the pump, use the centring ring and O-ring supplied.
- Remove the NW10 flange and connect to the 3/8 inch BSP threaded hole.
- Remove the NW10 flange and replace it with a NW25 flange adaptor (available as an optional accessory, see *Spares and accessories on page 36*) and then connect to the NW25 flange.

Take note of the following information when connecting the pump to the vacuum system. Refer to *Spares and accessories on page 36* for details of the accessories mentioned below.

- For optimum pumping speeds, ensure that the pipeline connected to the inlet-port is as short as possible and has an internal diameter not less than the inlet-port diameter.
- Support the vacuum pipelines to prevent loading of the coupling-joints.
- If necessary, incorporate flexible bellows in the system pipelines to reduce the transmission of vibration and to prevent loading of coupling-joints. If using flexible bellows, ensure that the bellows which have a maximum pressure rating which is greater than the highest pressure that can be generated in the system. We recommend you to use manufacturer's flexible bellows.
- Use a suitable inlet-filter if pumping condensable vapours or if using the pump for very dusty applications.
- Use a suitable valve to isolate the pump from the vacuum system when pumping condensable vapours or to maintain vacuum when the pump is switched off.
- Ensure that sealing surfaces are clean and scratch-free.



## 4.7.2 Side inlet-port connection

A side inlet-port is available, refer to *Figure: General view of the pump on page 11*. To use the side inlet-port, use the following procedure.

1. Carefully remove the side panel from the pump: use a suitable flat blade screwdriver or similar tool for this purpose. The panel is located by two nylon rivets.
2. Unscrew and remove the blanking plug with its O-ring.
3. Unscrew and remove the adaptor flange and its O-ring and replace it with the blanking plug and O-ring that was removed in Step 2.
4. Screw the adaptor flange and its O-ring into the side inlet-port.

## 4.8 Pump outlet connection



### WARNING:

Connect the pump outlet to a suitable treatment plant to prevent the discharge of dangerous gases and vapours to the surrounding atmosphere. Use a catchpot to prevent the drainage of contaminated condensate back into the pump.

To connect the pump to your outlet accessories or to the exhaust treatment plant:

- Connect a 10 mm internal diameter vacuum hose or 12 mm internal diameter plastic hose to the outlet nozzle (*Figure: General view of the pump on page 11*).
- Remove the outlet nozzle and connect to the 3/8 inch BSP tapped hole.
- Remove the outlet nozzle and replace it with an NW25 flange adaptor (available as an optional accessory, see *Spares and accessories on page 36*) and then connect to the NW25 flange.

Take note of the following information before connecting to the pump outlet:

- The exhaust system must be configured so that the maximum pressure at the pump outlet does not exceed 0.5 bar gauge (1.5 bar absolute,  $1.5 \times 10^5$  Pa) at full pump throughput.
- In the following circumstances, we recommend you to fitting an oil mist filter to the pump outlet
  - if using the pump with the gas-ballast control open
  - if operating the pump with an inlet pressure greater than 10 mbar for extended periods or
  - if frequently pumping down from atmospheric pressure.
- The mist filter will trap the oil exhausted from the pump: the oil can be re-used if it is not contaminated.

## 4.9 Leak-test the system

Leak-test the system and seal any leaks found after you have installed the pump, to prevent leakage of substances out of the system and leakage of air into the system.

## 5. Operation



### **WARNING:**

**Do not expose any part of the human body to vacuum. Failure to obey this warning could result in injury.**

### 5.1 ATEX directive implications

This equipment is designed to meet the requirements of Group II Category 3 equipment in accordance with Directive 2014/34/EU of the European Parliament and the Council of 26th February 2014 on the approximation of the laws of the Member States concerning equipment and protective systems intended for use in potentially explosive atmospheres. (The ATEX Directive)

The ATEX Category 3 applies in respect of potential ignition sources internal to the equipment. An ATEX Category has not been assigned in respect of potential ignition sources on the outside of the equipment as the equipment has not been designed for use where there is an external potentially explosive atmosphere.

There is no potential source of ignition within the pump during normal operation but there may be potential sources of ignition under conditions of predictable and rare malfunction as defined in the Directive. Accordingly, although the pump is designed to pump flammable materials and mixtures, operating procedures should ensure that under all normal and reasonably predictable conditions, these materials and mixtures are not within explosive limits. Category 3 is considered appropriate for the avoidance of ignition in the case of a rare malfunction which allows flammable materials or mixtures to pass through the pump whilst within their explosive limits.

#### 5.1.1 Flammable/pyrophoric materials



### **WARNING:**

**Obey the instructions and take note of the precautions given below to ensure that pumped gases do not enter their flammable ranges**

When flammable or pyrophoric materials are present within the equipment:

- Do not allow air to enter the equipment.
- Ensure that the system is leak tight.
- Use an inert gas purge (for example, a nitrogen purge) to dilute any flammable gases or vapours entering the pump inlet, and/or use an inert gas purge to reduce the concentration of flammable gases or vapours in the pump and in the exhaust pipeline to less than one quarter of the gases' published Lower Explosive Limits (LEL).
- Use an inert gas purge into the pump gas ballast connection to prevent the condensation of flammable vapours within the pump mechanism and exhaust pipeline.



## 5.1.2 Gas purges



### WARNING:

If using inert gas purges to dilute dangerous gases to a safe level, ensure that the pump is shut down if an inert gas supply fails.



### WARNING:

Obey the instructions and take note of the precautions given below to ensure that pumped gases do not enter their flammable ranges.

Switch on the inert gas purge to remove air from the pump and the exhaust pipeline before the process starts. Switch off the purge flow at the end of the process only after any remaining flammable gases or vapours have been purged from the pump and exhaust pipeline.

If liquids that produce flammable vapours could be present in the pump foreline, then the inert gas purge to the pump should be left on all the time this liquid is present. Flammable liquids could be present in the foreline as a result of condensation or may be carried over from the process.

When calculating the flow rate of inert gas required for dilution, consider the maximum flow rate for the flammable gases/vapours that could occur. For example, if a mass flow controller is used to supply flammable gases to the process, assume a flow rate for flammable gases that could arise if the mass flow controller is fully open.

Continually measure the inert gas purge flow rate: if the flow rate falls below that required, stop the flow of flammable gases or vapours into the pump.

#### Note:

*We recommend obtaining and reading the Vacuum Pump and Vacuum System Safety manual (publication number P40040100), available from us or the supplier.*

## 5.2 Gas-ballast control

Use the gas-ballast control (*Figure: General view of the pump on page 11*) to change the amount of air (or inert gas) introduced into the low vacuum stage of the pump. Use of the gas-ballast will prevent the condensation of vapours in the pump, the condensates would contaminate the oil.

Use the gas-ballast control closed:

- to achieve ultimate vacuum
- to pump dry gases.

Turn the gas-ballast control six turns anti-clockwise to open it fully. Use the gas-ballast control open:

- to pump high concentrations of condensable vapour
- to decontaminate the oil.

When operating the pump with the gas-ballast control open, there will be an increased rate of oil loss from the pump.

## 5.3 Start-up



### **WARNING:**

**Ensure that the system design does not allow the exhaust pipeline to be blocked**

If the oil is contaminated, or if the pump temperature is below 12 °C (53.6 °F), or if the electrical supply voltage is more than 10% below the lowest voltage specified for the pump, the pump may operate at a reduced speed for a few minutes. If the pump continues to operate at reduced speed, the motor thermal overload device will open and stop the pump. When the motor has cooled, the thermal overload device will reset automatically and the pump will restart.

1. Check that the pump oil-level is between the MAX and MIN marks on the bezel of the oil-level sight-glass, if it is not, refer to [Check the oil level on page 28](#).
2. Turn the gas-ballast control to the required position (refer to [Gas-ballast control on page 23](#)).
3. Switch on the electrical supply to the pump.
4. Check that the oil-level in the sight-glass drops slightly (3 to 5 mm) after start-up. This shows that the pump has primed with oil.
5. If the pump fails to prime, operate the pump with the inlet open to atmosphere for approximately 30 seconds. Then isolate the inlet and check that the oil-level drops by 3 to 5 mm.
6. To achieve ultimate vacuum, pump condensable vapours or decontaminate the pump oil, refer to the procedures in [To achieve ultimate vacuum on page 24](#), [To pump condensable vapours on page 25](#) and [To decontaminate the oil on page 25](#) respectively. Otherwise, open the vacuum system isolation-valve.

## 5.4 To achieve ultimate vacuum

If the pump does not achieve the performance specified in [Performance on page 12](#), make sure that this is not due to the system design before you contact supplier or us for advice. In particular, the vapour pressure of all materials used in the vacuum system (including pump oil) must be much lower than the specified ultimate vacuum of the pump.

Refer to [The pump fails to achieve specified performance \(failure to reach ultimate vacuum\)](#) for a list of possible causes for failure to achieve the specified performance, note however that the most common causes are:

- Pressure measurement technique or gauge head is unsuitable or the gauge head is faulty.
- Use of an oil other than the recommended oil and the vapour pressure of the oil is higher than the specified ultimate vacuum of the pump.

Use the following procedure to achieve ultimate vacuum:

1. Isolate the pump from the vacuum system.
2. Turn the gas-ballast control fully anti-clockwise (fully open) and operate the pump for at least 1 hour (or overnight) to thoroughly purge the oil of contaminants.



3. Close the gas-ballast control.
4. Open the vacuum system isolation-valve and pump down to ultimate vacuum.

## 5.5 To pump condensable vapours

Use gas-ballast (open the gas-ballast control) when there is a high proportion of condensable vapours in the process gases:

1. Close the vacuum system isolation-valve.
2. Turn the gas-ballast control anti-clockwise to fully open and operate the pump for 30 minutes to warm the oil, this will help to prevent vapour condensation in the pump.
3. Open the vacuum system isolation-valve and continue to operate the pump with the gas-ballast control open.

After pumping condensable vapours, decontaminate the oil (if necessary), use the procedure in [To decontaminate the oil on page 25](#).

## 5.6 To decontaminate the oil

The oil in the pump should be clear. If the oil is cloudy or discoloured, it is contaminated with process vapours.

1. Look at the condition of the oil in the oil sight-glass ([Figure: General view of the pump on page 11](#)). If the oil is cloudy or discoloured, continue with the procedure at step 2 below.
2. Close the vacuum system isolation-valve.
3. Turn the gas-ballast control fully anti-clockwise.
4. Operate the pump until the oil is clear.

## 5.7 Unattended operation

The pump is designed for unattended operation under the normal operating conditions specified in [Operating and storage conditions on page 12](#). However, we recommend you to checking the pump at a regular interval of not more than 14 days, check the pump more frequently if pumping high volumes of gas or if operating the pump with the gas-ballast control open.

The motor is protected by an overload device which isolates the pump from the electrical supply when critical temperature or current levels are exceeded. The overload device resets automatically when the motor has cooled. When checking the pump, make sure that the pump is not going through a repetitive cycle of thermal overload failures and automatic resets. If necessary, reduce the thermal load from the pumped gases, to prevent overheating of the pump.

## 5.8 Shut-down

 **Note:**

*If the gas-ballast control is open and the motor is switched off for any reason, the pump drive shaft may rotate in the reverse direction, causing a system pressure rise. To prevent*

*this, use a gas-ballast control valve (refer to [Solenoid operated gas-ballast control valve on page 38](#)).*

We recommend, as described in the procedure below, decontaminating the oil before shutting down the pump, this will prevent damage to the pump by the contaminants in the oil.

1. Refer to [To decontaminate the oil on page 25](#) and decontaminate the oil, as required.
2. Close the vacuum system isolation-valve (if not already closed).
3. Close gas-ballast (that is, turn the gas-ballast control clockwise).
4. Switch off the electrical supply to the pump.



## 6. Maintenance

### 6.1 Safety information



**WARNING:**

Allow the pump to cool (so that it is at a safe temperature for skin contact) before starting maintenance work. Make sure the pump is switched off in case the thermal overload device restarts the pump.



**WARNING:**

Obey the safety instructions given below and take note of appropriate precautions. Failure to do so can cause injury to people and damage to equipment.

- A suitably trained and supervised technician must maintain the pump. Obey your local and national safety requirements.
- Ensure that the maintenance technician is familiar with the safety procedures which relate to the pump-oil and the products processed by the pumping-system.
- Isolate the pump and other components in the pumping system from the electrical supply so that they cannot be operated accidentally.
- After maintenance is completed, recheck the pump rotation direction if the electrical supply has been disconnected.
- Do not reuse O-rings and seals if they are damaged.
- The pump and its fluid will be contaminated with the process chemicals that have been pumped during operation. Ensure that the pump is decontaminated before maintenance and that adequate precautions are taken to protect people from the effects of dangerous substances if contamination has occurred.
- Do not touch or inhale the thermal breakdown products of fluorinated materials which may be present if the pump has been heated to 260 °C (500 °F) and above. These breakdown products are very dangerous. Fluorinated materials in the pump may include oils, greases and seals. The pump may have overheated if it was misused, if it malfunctioned or if it was in a fire. Our Material Safety Data Sheets for fluorinated materials used in the pump are available on request: contact us or your supplier.
- Leak-test the system after maintenance work is complete if any vacuum or exhaust joints were connected or disconnected, seal any leaks found.

### 6.2 Maintenance plan

The plan shown in details the routine maintenance operations necessary to maintain the pump in normal use. Instructions for each operation are given in the section shown.

More frequent maintenance may be required if the pump is used to process corrosive or abrasive gases and vapours, in these circumstances, we recommend you to replace the pump seals every year. If necessary, adjust the maintenance plan according to experience.

When carrying out maintenance on the pump, use our spares and maintenance kits, these contain all the components necessary to complete maintenance operations successfully. The item numbers of the spares and kits are given in [Spares on page 36](#).

Examine the condition of any external accessory, filters or traps (if fitted) when carrying out maintenance on the pump. Refer to the instructions supplied with these accessories for the necessary maintenance procedures.

*Table 9 Maintenance plan*

Operation	Frequency	Refer to section
Check the oil-level	Monthly	<a href="#">Check the oil level on page 28</a>
Replace the oil	3000 operation hours	<a href="#">Replace the oil on page 29</a>
Inspect and clean the inlet-filter	Every oil change	<a href="#">Inspect and clean the inlet-filter on page 29</a>
Clean or replace the gas-ballast O-ring	Every oil change	<a href="#">Clean or replace the gas-ballast O-ring on page 30</a>
Clean the motor fan-cover	Yearly	<a href="#">Clean the motor fan-cover and enclosure on page 31</a>
Clean and overhaul the pump	15000 operation hours	<a href="#">Clean and overhaul the pump on page 31</a>
Fit new blades	30000 operation hours	<a href="#">Fit new blades on page 31</a>
Replace the capacitor	Every 4 years	<a href="#">Replace the capacitor and test the motor on page 31</a>
Test the motor condition	Every 15000 hours of operation	<a href="#">Replace the capacitor and test the motor on page 31</a>

## 6.3 Check the oil level

### Note:

1. If required, it is possible to check the oil-level while the pump is operating, however the pump must be switched off. Isolate the pump and other components in the pumping system from the electrical supply before pouring oil into the pump.
2. Do not mix hydrocarbon lubricants with PFPE or vice versa. If the oil is mixed, drain and refill with clean oil as described in [Replace the oil on page 29](#).

Refer to [Figure: General view of the pump on page 11](#) for the items in brackets.

1. Check that the oil-level in the oil sight-glass is between the MAX and MIN level marks on the bezel of the oil sight-glass.
2. If the oil-level is near to or below the MIN level mark, remove the oil filler-plug and pour more oil into the reservoir until the oil reaches the MAX level mark. If the oil-level goes above the MAX mark, remove the oil drain-plug and drain the excess oil from the pump. Refit the oil drain-plug. Refit the oil filler-plug.
3. If the oil is contaminated, drain and refill the pump with clean oil as described in [Replace the oil on page 29](#).

## 6.4 Replace the oil

Refer to *Figure: General view of the pump on page 11* for the items in brackets.

1. Operate the pump for approximately ten minutes to warm the oil, then switch off the pump. (This lowers the viscosity of the oil and allows the oil to be drained from the pump more easily).
2. Isolate the pump from the electrical supply and disconnect it from the vacuum system.
3. Remove the oil filler-plug.
4. Place a suitable block under the pump-motor to tilt the pump and place a suitable container under the oil drain-plug (gravity drain). Remove the oil drain-plug and allow the oil to drain into the container.
5. If the oil is dirty or contaminated:
  - Refit the oil drain-plug and pour clean oil into the pump.
  - Reconnect the pump to the electrical supply and operate the pump for about 5 to 10 minutes.
  - Disconnect the pump from the electrical supply, remove the oil drain-plug and allow the oil to drain out of the pump.
  - Repeat this step until the oil reservoir is clean.
6. Refit the oil drain-plug, remove the block and reconnect the pump to the vacuum system.
7. Fill a suitable container with clean oil and pour the oil into the filler hole until the oil-level reaches the MAX level mark on the bezel of the oil sight-glass.
8. Allow a few minutes for the oil to drain into the pump. If necessary, add more oil. Refit the oil filler-plug.

## 6.5 Inspect and clean the inlet-filter

Refer to *Figure: Inlet-filter removal and replacement on page 30*.

1. Unscrew the inlet adaptor and remove the inlet-filter and O-ring.
2. Wash the filter in a suitable cleaning solution. Allow the filter to dry.
3. Refit the O-ring, inlet-filter and inlet adaptor.



Figure 3 Inlet-filter removal and replacement

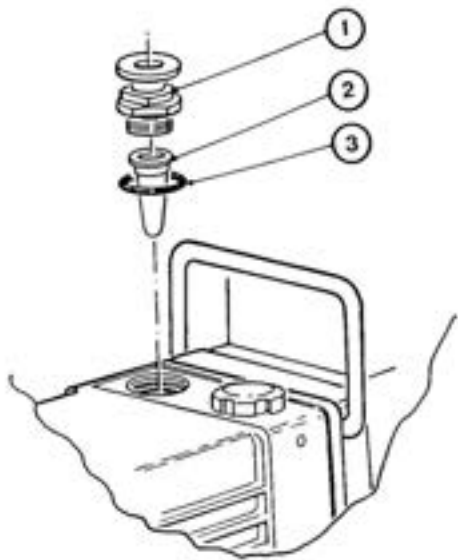

1. Inlet adaptor
3. O-ring

2. Inlet-filter

## 6.6 Clean or replace the gas-ballast O-ring

### Note:

*The filter element is retained in its seating with adhesive, do not try to remove it.*

Refer to [Figure: Gas-ballast O-ring removal and replacement on page 31](#).

1. Unscrew and remove the gas-ballast control.
2. Remove the O-ring from the control.
3. Wash the O-ring in a suitable cleaning solution. Replace the O-ring if it is damaged.
4. Replace the O-ring carefully on its seat. Screw the gas-ballast control back into the pump and reset to the required position.



Figure 4 Gas-ballast O-ring removal and replacement

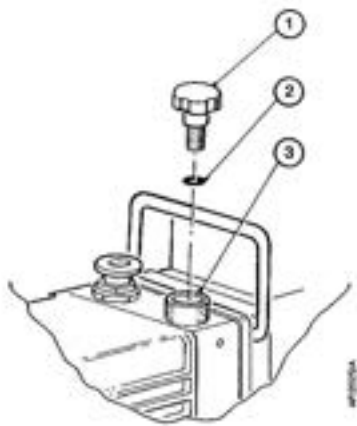

1. Gas-ballast control
3. Filter element

2. O-ring

## 6.7 Clean the motor fan-cover and enclosure

If the motor fan-cover and enclosure are not kept clean, the air flow over the motor can be restricted and the pump may overheat.

1. Switch off the pump and disconnect it from the electrical supply.
2. Use a dry cloth and a brush to remove dirt and deposits from the fan-cover and enclosure.

## 6.8 Clean and overhaul the pump

Clean and overhaul the pump as described in the instructions supplied with the clean and overhaul kit (see [Spares and accessories on page 36](#)).

## 6.9 Fit new blades

Fit new blades to the pump as described in the instructions supplied with the blade kit (see [Spares and accessories on page 36](#)).

## 6.10 Replace the capacitor and test the motor

Replace the capacitor as described in the instructions supplied with the capacitor kit.

Test the earth (ground) continuity and the insulation resistance of the pump motor, in accordance with local regulations for periodic testing of electrical equipment. As per our recommendation:

- The earth (ground) continuity is less than 0.1  $\Omega$ .
- Insulation resistance is greater than 10 M $\Omega$ .

If the motor fails these tests, it motor must be replaced.

## 7. Fault finding

A list of fault conditions and their possible causes is provided here to assist in basic fault-finding. If unable to rectify a fault when using this guide, call your supplier or our nearest service centre for advice.

### 7.1 The pump has failed to start

- The electrical supply fuse has failed.
- The motor is incorrectly wired.
- The operating voltage does not match that of the motor.
- The exhaust filter or exhaust line is blocked.
- The oil temperature is below 12 °C.
- The oil is too viscous.
- The oil is contaminated.
- The pump is seized after long storage or has been left to stand after pumping contaminants.
- The motor is faulty.

### 7.2 The pump fails to achieve specified performance (failure to reach ultimate vacuum)

- The measuring technique or gauge is unsuitable.
- There is a leak in the external vacuum system.
- The gas-ballast control is open.
- The oil level is too low.
- The pump has been filled with the wrong type of oil.
- The oil is contaminated.
- The pump has not primed.
- The vacuum fittings are dirty.
- The inlet-filter is blocked.
- The pump has not warmed up.

### 7.3 The pump is noisy

- The motor fan-cover is damaged.
- The motor bearings are worn.
- The oil is contaminated with solid particles.
- One of the pump blades is sticking.

### 7.4 The pump surface temperature is above 100 °C

- The ambient temperature is too high.
- The cooling-air supply is insufficient or is too hot.
- The cooling-air supply is blocked.

- The electrical supply voltage is too high.
- The exhaust filter or exhaust line is blocked.
- The oil level is too low.
- The pump is filled with the wrong type of oil.
- The oil is contaminated.
- The process gas is too hot or the throughput is too high.

### **7.5 The vacuum is not maintained after the pump is switched off**

- The gas-ballast control is open.
- O-ring(s) are damaged or missing.
- The shaft seals have deteriorated.

### **7.6 The pumping speed is poor**

- The connecting pipelines are too small in diameter.
- The connecting pipelines are too long.
- The inlet-filter is blocked.

### **7.7 There is an external oil leak**

- The oil pump shaft seal is worn or damaged.
- The oil box gasket has deteriorated.
- There is an oil leak from gas-ballast control.
- There is an oil-leak from the drain-plug.

## 8. Storage



### CAUTION:

Observe the storage temperature limits stated in [Technical data on page 12](#). Storage below - 30 °C will permanently damage the pump seals.

### Note:

*If you will store a new pump in conditions of high humidity, remove the pump from its cardboard packaging box, dispose of the box (refer to [Disposal on page 35](#)).*

Use the following procedure to store the pump:

1. Ensure that the pump has been shut-down as described in [Operation on page 22](#).
2. Isolate the pump from the electrical supply.
3. Purge your vacuum system and the pump with dry nitrogen and disconnect the pump from your vacuum system.
4. Replace the oil as described in [Replace the oil on page 29](#).
5. Place and secure protective covers over the inlet and outlet-ports.
6. Store the pump in cool, dry conditions until required for use.
7. When required, prepare and install the pump as described in [Installation on page 17](#). If the pump has been stored for more than a year, before you install the pump you must clean and overhaul it as described in the instruction supplied with the clean and overhaul kit.



## 9. Disposal

Dispose of the pump, the oil and any components removed from the pump safely in accordance with all local and national safety and environmental requirements.

Particular care must be taken with components and waste oil which have been contaminated with dangerous process substances.

Do not incinerate fluoroelastomer seals and O-rings.

## 10. Spares and accessories

Our products, spares and accessories are available from our companies in Belgium, Brazil, China, France, Germany, Israel, Italy, Japan, Korea, Singapore, United Kingdom, U.S.A and a world-wide network of distributors. The majority of these centres employ service engineers who have undergone comprehensive our training courses.

Order spare parts and accessories from our nearest company or distributor. When ordering, state for each part required:

- Model and item number of the equipment
- Serial number
- Item number and description of part.

### 10.1 Spares

The following maintenance kits contain all of the parts needed to maintain your pump. The maintenance kits also include instructions for the use of the kits.

Use the clean and overhaul kit for routine maintenance operations. Use the blade kit together with the clean and overhaul kit when renewing the blade assembly in the rotary pump.

*Table 10 Spares item numbers*

Maintenance kit	Item number
E2M0.7/E2M1/E2M1.5 clean and overhaul kit	A37101131
E2M0.7/E2M1/E2M1.5 blade kit	A37101132
Ultragrade 15 oil (1 litre)	H11026015
Capacitor kit for part numbers A37131902 / A37122902 / A37103902 (110-120 V 30 $\mu$ F)	A50584808
Capacitor kit for part numbers A37131919 / A37122919 / A37103919 (220-240 V 8 $\mu$ F)	A50584809

### 10.2 Accessories

A comprehensive range of accessories is available for the pumps, refer to [Figure: Accessories on page 37](#).

Items marked \* require an NW25 adaptor, described in [Pump inlet or outlet NW25 adaptor on page 39](#).

Figure 5 Accessories

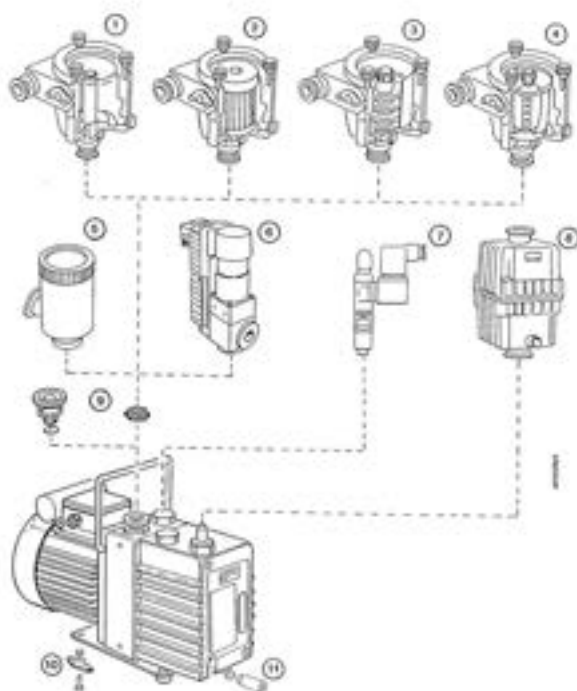

- |  |                                     |
|--|-------------------------------------|
| 1. Inlet catchpot                      | 2. Inlet dust filter                |
| 3. Inlet desiccant trap                | 4. Inlet chemical trap              |
| 5. Foreline trap                       | 6. Solenoid operated pipeline valve |
| 7. Solenoid operated gas-ballast valve | 8. Outlet mist filter               |
| 9. Flange adaptor kit                  | 10. Vibration isolators             |
| 11. Oil drain extension                |                                     |

### 10.2.1 Inlet catchpot

The inlet catchpot traps any liquid droplets and prevents their entry into the pump.

Product	Item number
IT020K Inlet catchpot*	A44110000

### 10.2.2 Inlet dust filter

The inlet dust filter protects the pump against abrasive dust.

Product	Item number
ITF20K Inlet dust filter*	A44215000

### 10.2.3 Inlet desiccant trap

Use a desiccant trap when pumping limited quantities of water vapour at high pumping speeds to a low vapour pressure.

Product	Item number
ITD20K Inlet desiccant trap*	A44510000

### 10.2.4 Inlet chemical trap

The inlet chemical trap protects the pump against chemically active gases.

Product	Item number
ITC20K Inlet chemical trap*	A44410000

### 10.2.5 Solenoid operated gas-ballast control valve

The valve provides remote or automatic on/off control of gas-ballast. The valve can be connected to shut-off ballast to prevent the return of air to the vacuum system when the pump is switched off.

Product	Electrical supply	Item number
EBV20 gas-ballast control valve	220-240 V, single-phase, 50-60 Hz	A50006930
	100-120 V, single-phase, 50-60 Hz	A50006984

### 10.2.6 Foreline trap

Use a foreline trap on a clean pumping system to prevent back-migration of rotary pump oil vapour into your vacuum system.

Product	Item number
FL20K Foreline trap*	A13305000

### 10.2.7 Solenoid operated pipeline valve

Fit the pipeline valve between the vacuum system and the pump inlet to provide additional system protection when the pump is switched off.

Product	Electrical supply	Item number
PV10EK valve*	200-240 V, single-phase, 50-60 Hz	C41101000
	110-127 V, single-phase, 50-60 Hz	C41103000

### 10.2.8 Outlet mist filter

The outlet mist filter separates and traps oil droplets in the pump outlet to prevent oil mist discharge.

Product	Item number
EMF3 Outlet mist filter	A46220000

### 10.2.9 Oil drain extension

Fit the oil drain extension between the oil drain port on the pump and the oil drain-plug to make the drainage of oil from the pump easier. The pack includes an oil drain extension tube for use when oil is gravity drained.

Product	Item number
Oil drain extension	A50503000



### 10.2.10 Vibration isolators

The vibration isolators reduce transmission vibration and noise when the pump is floor or frame mounted and to help to reduce strain when the mounting area is uneven.

Product	Item number
Vibration isolators (pack of four)	A24801407

### 10.2.11 Pump inlet or outlet NW25 adaptor

This is a 3/8 inch BSP to NW25 adaptor, supplied with connection hardware. Use this adaptor when removing the NW10 adaptor fitted to the pump-inlet or the outlet-nozzle fitted to the pump outlet, to adapt the 3/8 inch BSP thread to NW25.

Product	Item number
Pump inlet adaptor	A37101028

## 11. Service

Our products are supported by a world-wide network of our service centres. Each service centre offers a wide range of options including equipment decontamination, service exchange, repair, rebuild and testing to factory specifications. Equipment which has been serviced, repaired or rebuilt is returned with a full warranty.

The local service centre can also provide our engineers to support on-site maintenance, service or repair of the equipment.

For more information about service options, contact the nearest service centre or our other company.

### 11.1 Return the equipment or components for service

Before you send your equipment to us for service or for any other reason, you must send us a completed Declaration of Contamination of Vacuum Equipment and Components – Form HS2. The HS2 form tells us if any substances found in the equipment are hazardous, which is important for the safety of our employees and all other people involved in the service of your equipment. The hazard information also lets us select the correct procedures to service your equipment.

We provide instructions for completing the form in the Declaration of Contamination of Vacuum equipment and Components – Procedure HS1.

If you are returning a vacuum pump, note the following:

- If a pump is configured to suit the application, make a record of the configuration before returning the pump. All replacement pumps will be supplied with default factory settings.
- Do not return a pump with accessories fitted. Remove all accessories and retain them for future use.
- The instruction in the returns procedure to drain all fluids does not apply to the lubricant in pump oil reservoirs.

Download the latest documents from [www.edwardsvacuum.com/HSForms/](http://www.edwardsvacuum.com/HSForms/), follow the procedure in HS1, fill in the electronic HS2 form, print it, sign it, and return the signed copy to us.



#### NOTICE:

**If we do not receive a completed HS2 form, your equipment cannot be serviced.**



