

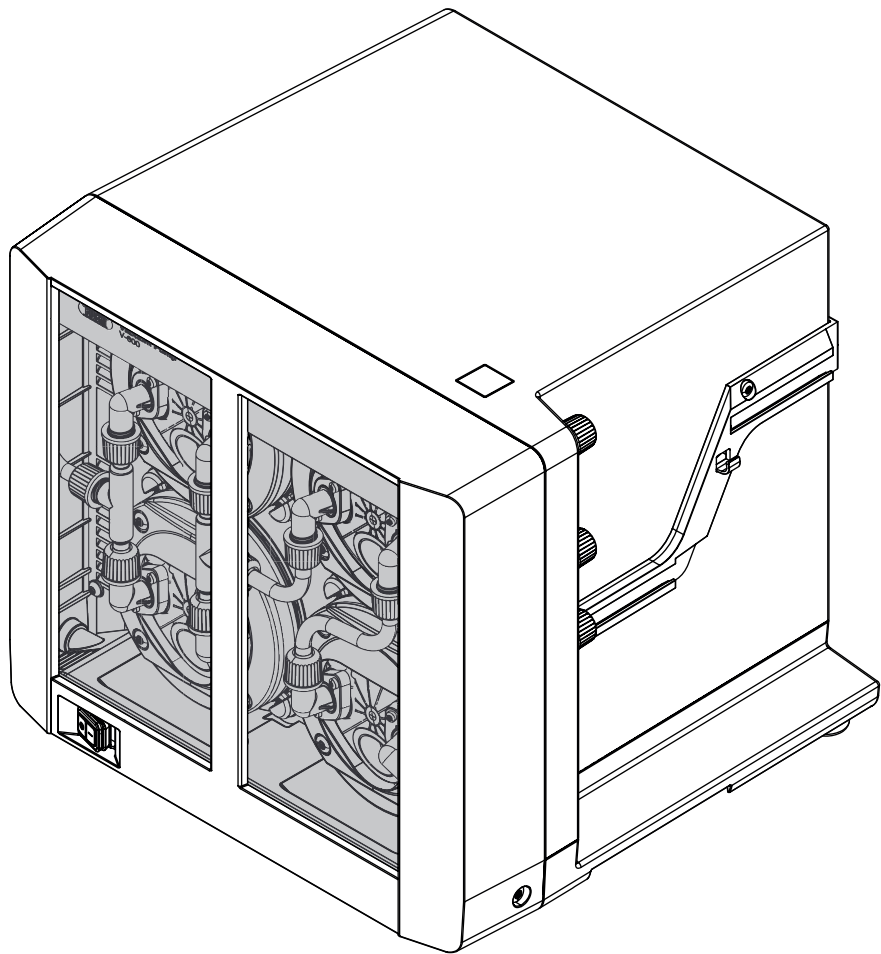

# Vacuum Pump V-600

## Operation Manual



## **Imprint**

Product Identification:

Operation Manual (Original) Vacuum Pump V-600  
11593885

Publication date: 03.2023

Version I

BÜCHI Labortechnik AG

Meierseggstrasse 40

Postfach

CH-9230 Flawil 1

E-Mail: [quality@buchi.com](mailto:quality@buchi.com)

BUCHI reserves the right to make changes to the manual as deemed necessary in the light of experience, especially with respect to structure, illustrations and technical details.

This manual is copyrighted. Information from it may neither be reproduced, distributed, or used for competitive purposes, nor made available to third parties. The manufacture of any component with the aid of this manual without prior written agreement is also prohibited.

## Contents

<b>1</b>	<b>About this document.....</b>	<b>6</b>
1.1	Connected devices .....	6
1.2	Warning notices in this document.....	6
1.3	Symbols.....	6
1.3.1	Warning symbols .....	6
1.3.2	Mandatory directive symbols .....	7
1.3.3	Other symbols .....	7
1.4	Available languages .....	7
1.5	Trademarks .....	7
<b>2</b>	<b>Safety.....</b>	<b>8</b>
2.1	Intended use.....	8
2.2	Use other than that intended .....	8
2.3	Staff qualification .....	8
2.4	Residual risks .....	9
2.4.1	Dangerous vapors .....	9
2.4.2	Faults during operation.....	9
2.4.3	Hot surfaces .....	9
2.5	Personal protective equipment.....	10
2.6	Modifications.....	10
<b>3</b>	<b>Product description.....</b>	<b>11</b>
3.1	Description of function .....	11
3.2	ATEX II 3G T3 IIC X rating .....	11
3.3	Configuration .....	12
3.3.1	Front view .....	12
3.3.2	Rear view.....	13
3.3.3	Connections.....	14
3.3.4	Internal view .....	16
3.3.5	Type plate.....	17
3.3.6	ATEX supplementary plate.....	17
3.4	Specifications supplied .....	18
3.5	Technical data .....	19
3.5.1	Vacuum Pump.....	19
3.5.2	Ambient conditions .....	19
3.5.3	Materials.....	19
<b>4</b>	<b>Transport and storage .....</b>	<b>21</b>
4.1	Transport .....	21
4.2	Storage .....	21

<b>5</b>	<b>Installation.....</b>	<b>22</b>
5.1	Important considerations prior to commissioning .....	22
5.2	Installation site .....	23
5.3	Securing against earthquakes .....	24
5.4	Connecting laboratory equipment.....	25
5.5	Connecting the silencer .....	26
	5.5.1 Connecting silencer directly to V-600 .....	26
	5.5.2 Connecting the silencer to the outlet of the secondary condenser .....	27
5.6	Connecting a Woulff bottle .....	28
	5.6.1 Connecting the Vacubox via a Woulff bottle .....	28
5.7	Connecting a secondary condenser .....	31
5.8	Connecting a secondary cold trap .....	32
5.9	Fitting an Interface I-300.....	33
5.10	Fitting a VacuBox .....	33
5.11	Connecting the vacuum pump to the power supply.....	35
5.12	Connecting communication cables to the V-600 .....	36
5.13	Assembling the BUCHI distillation system.....	37
	5.13.1 Overview: Setting up communication connections (COM) .....	38
	5.13.2 Overview: setting up coolant tubing connections .....	39
	5.13.3 Overview: setting up vacuum tubing connections .....	40
5.14	Operating the Vacuum Pump V-600 with 2 Rotavapor systems .....	41
<b>6</b>	<b>Operation.....</b>	<b>44</b>
6.1	Operating V-600 without Interface I-300/I-300 Pro .....	44
6.2	Operating V-600 with Interface I-300/I-300 Pro .....	44
<b>7</b>	<b>Cleaning and servicing .....</b>	<b>45</b>
7.1	Cleaning .....	45
	7.1.1 Important considerations when cleaning .....	45
	7.1.2 Cleaning the pump .....	45
	7.1.3 Cleaning the casing .....	46
	7.1.4 Cleaning glass components .....	46
	7.1.5 Cleaning internal pump tubing.....	47
	7.1.6 Cleaning the diaphragm .....	47
7.2	Servicing.....	47
	7.2.1 Notes on servicing .....	47
	7.2.2 Dismantling and reassembling pump head .....	49
	7.2.3 Replacing the diaphragm.....	53
	7.2.4 Replacing the non-return valve.....	55
	7.2.5 Replacing connecting tubes .....	57
	7.2.6 Replacing O-rings.....	60
	7.2.7 Removing non-return valve from elbow connector .....	61
	7.2.8 Fitting GL14 cap nut with tube seal .....	62
<b>8</b>	<b>Help with faults .....</b>	<b>63</b>
8.1	Faults, possible causes and remedies .....	63
8.2	Customer service.....	64
<b>9</b>	<b>Taking out of service and disposal.....</b>	<b>65</b>
9.1	Taking out of service .....	65
9.2	Disposal.....	65



---

<b>10</b>	<b>Appendix .....</b>	<b>66</b>
10.1	Solvent table .....	66
10.2	Spare parts and accessories .....	68
	10.2.1 Accessories .....	68
	10.2.2 Wearing parts .....	71
	10.2.3 Spare parts .....	72
10.3	Document: 11594022 ATEX .....	74
10.4	Health and safety approval .....	76
10.5	Health and safety .....	77

## 1 About this document

These operating instructions describe the [Vacuum Pump V-600] at the time supplied. They are an integral part of the product and contain important information that is necessary for safe operation and maintenance.

These operating instructions apply to all variants of the [Vacuum Pump V-600] and are intended primarily for laboratory staff.

- ▶ To ensure safe and trouble-free operation, read these operating instructions before starting up the device and follow the guidance they contain.
- ▶ Keep the operating instructions somewhere near to the device.
- ▶ Pass on the operating instructions to any subsequent owner or user.

BÜCHI Labortechnik AG accepts no liability whatsoever for any faults or damage that result from the failure to follow these operating instructions.

- ▶ If you still have any questions after reading these operating instructions, please contact BÜCHI Labortechnik AG Customer Service. Contact details for your local agents can be found on the back cover of these operating instructions or on the Internet at <http://www.buchi.com>.

### 1.1 Connected devices

In addition to these operating instructions, you should also follow the instructions and specifications in the documentation for the connected devices.

### 1.2 Warning notices in this document





Warning notices warn you of dangers that can occur when handling the device. There are four danger levels, each identifiable by the signal word used.









Signal word	Meaning
DANGER	Indicates a danger with a high level of risk which could result in death or serious injury if not prevented.
WARNING	Indicates a danger with a medium level of risk which could result in death or serious injury if not prevented.
CAUTION	Indicates a danger with a low level of risk which could result in minor or medium-severity injury if not prevented.
NOTICE	Indicates a danger that could result in damage to property.

### 1.3 Symbols





The following symbols may be displayed in this instruction manual or on the device:

#### 1.3.1 Warning symbols

Symbol	Meaning	Symbol	Meaning
	General warning		Corrosive substance
	Dangerous electrical voltage		Flammable substance

Symbol	Meaning	Symbol	Meaning
	Biological hazard		Potentially explosive atmosphere
	Breakable items		Dangerous gases
	Hot surface		Health-harming or irritant substances
	Risk of hand injury		Strong magnetism

### 1.3.2 Mandatory directive symbols

Symbol	Meaning	Symbol	Meaning
	Wear safety goggles		Wear protective clothing
	Wear protective gloves		Heavy load, do not lift without assistance

### 1.3.3 Other symbols



#### NOTE

This symbol draws attention to useful and important information.

- ☑ This character draws attention to a requirement that must be met before the instructions below are carried out.
- ▶ This character indicates an instruction that must be carried out by the user.
- ⇒ This character indicates the result of a correctly carried out instruction.

## 1.4 Available languages

These operating instructions were originally produced in German and have been translated into several other languages. The translations are available on the enclosed CD or can be obtained as a PDF file via <http://www.buchi.com>.

## 1.5 Trademarks

Product names and registered or unregistered trademarks that are used in this instruction manual are used only for identification and remain the property of the owner in each case.

For example, Rotavapor® is a registered trademark of BÜCHI Labortechnik AG.

## 2 Safety

### 2.1 Intended use

The [Vacuum Pump V-600] has been designed and built as an item of laboratory equipment. Its intended use is the evacuation of laboratory apparatus. This is done by means of a PTFE-diaphragm pump – with or without regulation by a vacuum controller.

PTFE-diaphragm pumps are used primarily for the following applications:

- Evacuating distillation apparatus, in particular rotary evaporators (Rotavapor®)
- Vacuum filtration
- Vacuum-drying cabinets
- Drying kilns

### 2.2 Use other than that intended

Use of any kind other than that referred to and any application that does not comply with the technical specifications constitutes use other than that intended. The operator alone is liable for any damage brought about by use of the device in a manner other than that intended.

The following uses are expressly forbidden:

- Use in areas which require explosion-safe apparatus.
- Pumping of liquids and solid particles.
- Processing samples which could be caused to explode or ignite by impact, friction, heat or sparks (e.g. explosives).
- Use for analysis (e.g. Kjeldahl).
- Drawing in fluids with an intake pressure higher than atmospheric pressure.
- Operation at ambient temperatures >40 °C.
- In ATEX II 3G T3 IIC X mode, drawing in fluids with a temperature > 40°C.
- In ATEX II 3G T3 IIC X mode, use of fluids with a flashpoint < 200°C.

### 2.3 Staff qualification

Unqualified persons are unable to identify risks and are therefore exposed to greater dangers.

The device may only be operated by suitably qualified laboratory staff.

These operating instructions are aimed at the following target groups:

#### Users

Users are persons that meet the following criteria:

- They have been instructed in the use of the device.
- They are familiar with the contents of these operating instructions and the applicable safety regulations and apply them.
- They are able on the basis of their training or professional experience to assess the risks associated with the use of the device.

## Operator

The operator (generally the laboratory manager) is responsible for the following aspects:

- The device must be correctly installed, commissioned, operated and serviced.
- Only suitably qualified staff may be assigned the task of performing the operations described in these operating instructions.
- The staff must comply with the local applicable requirements and regulations for safe and hazard-conscious working practices.
- Safety-related incidents that occur while using the device should be reported to the manufacturer (quality@buchi.com).

## BUCHI service technicians

Service technicians authorized by BUCHI have attended special training courses and are authorized by BÜCHI Labortechnik AG to carry out special servicing and repair measures.

## 2.4 Residual risks

The device has been developed and manufactured using the latest technological advances. Nevertheless, risks to persons, property or the environment can arise if the device is used incorrectly.

Appropriate warnings in this manual serve to alert the user to these residual dangers.

### 2.4.1 Dangerous vapors

Distillation can produce dangerous vapors that are capable of causing life-threatening toxic effects.

- ▶ Do not inhale any vapors produced during distillation.
- ▶ Ensure that vapors are removed by a suitable fume hood.
- ▶ Only use the device in well ventilated areas.
- ▶ If vapors escape from joints or connections, check the seals concerned and replace them if necessary.
- ▶ Do not distill any unknown fluids.
- ▶ Observe the safety data sheets for all fluids used.

### 2.4.2 Faults during operation

If a device is damaged, sharp edges or exposed electrical wires can cause injuries.

- ▶ Regularly check device for visible damage.
- ▶ If faults occur, switch off the device immediately, unplug the power cord and inform the operator.
- ▶ Do not continue to use devices that are damaged.

### 2.4.3 Hot surfaces

The surfaces of the device can become very hot. If touched they can cause skin burns.

- ▶ Do not touch hot surfaces or else wear suitable protective gloves.

## 2.5 Personal protective equipment

Depending on the application, hazards due to heat and/or corrosive chemicals may arise.

- ▶ Always wear appropriate personal protective equipment such as safety goggles, protective clothing and gloves.
- ▶ Make sure that the personal protective equipment meets the requirements of the safety data sheets for all chemicals used.

## 2.6 Modifications

Unauthorized modifications may impair safety and lead to accidents.

- ▶ Use only genuine BUCHI accessories, spare parts and consumables.
- ▶ Technical modifications to the device or accessories should only be carried out with the prior written approval of BÜCHI Labortechnik AG and only by authorized BUCHI technicians.

BUCHI accepts no liability whatsoever for damage arising as a result of unauthorized modifications.

## 3 Product description

### 3.1 Description of function

The Vacuum Pump V-600 is intended for evacuating laboratory apparatus to a terminal vacuum of 1.5 mbar ( $\pm 1$  mbar). It can be operated either as a standalone device or combined with optional accessories (see Chapter 3.4 "Specifications supplied", page 18).

Once switched on, the Vacuum Pump V-600 runs in continuous mode unless it is connected to the Interface I-300/I-300 Pro unit. In unregulated continuous mode, the pump runs at a maximum speed of 1500 rpm and generates a terminal vacuum of 1.5 mbar ( $\pm 1$  mbar). The time required for evacuation depends on the size (volume) of the vessel.

When operating as a standalone unit, the Vacuum Pump V-600 automatically switches to energy saving mode after 1 hour of operation. In energy saving mode, the Vacuum Pump V-600 runs at 80 % of maximum speed but still generates the same terminal vacuum of 1.5 mbar ( $\pm 1$  mbar). After 2 hours of operation, the speed reduces to 50% of maximum while still maintaining the same terminal vacuum.

### 3.2 ATEX II 3G T3 IIC X rating

The vacuum pump has an ATEX II 3G T3 IIC X rating according to the ATEX Directive of the European Union.

The rating applies exclusively to the area of the unit in contact with the fluid inside the vacuum pump.

The vacuum pump is not suitable for operation in an environment with a potentially explosive atmosphere.

According to the ATEX II 3G T3 IIC X rating, the vacuum pump is suitable for pumping explosive fluids.

#### The meaning of the classification code:

Code	Meaning according to Directive 2014/34/EU
II	Equipment in this category is intended for use in areas that can be exposed to potentially explosive atmospheres.
3G	Equipment in this category is intended for use in areas in which it is unlikely that an explosive atmosphere will be created by gases, vapors, mist or swirling dust, but if such an atmosphere does nevertheless occur, then in all probability it will happen only rarely and for a short period of time.
IIC	Equipment in this category is suitable for processing fluids in the explosive class IIC.
T3	Equipment in this category is suitable for processing fluids with a flashpoint $> 200^{\circ}\text{C}$ .

Code	Meaning according to Directive 2014/34/EU
X	<p>Equipment in this category is subject to special requirements to satisfy the classification specified.</p> <p>Requirements for satisfying the classification:</p> <ul style="list-style-type: none"><li>• See Chapter 3.5 "Technical data", page 19</li><li>• See Chapter 2.2 "Use other than that intended", page 8</li><li>• See Chapter 7 "Cleaning and servicing", page 45</li></ul>

### 3.3 Configuration

#### 3.3.1 Front view

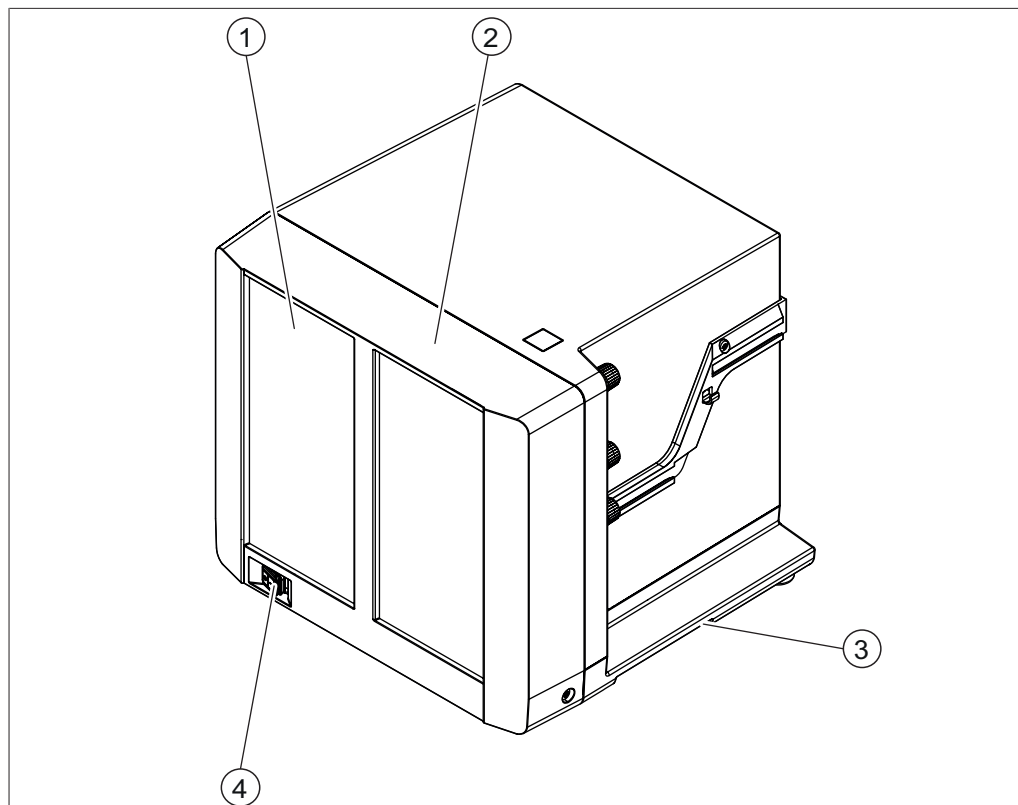

Fig. 1: Design of V-600

- |   |                   |   |                      |
|---|-------------------|---|----------------------|
| 1 | Inspection window | 3 | Recessed grip        |
| 2 | Casing front      | 4 | On/Off master switch |



### 3.3.2 Rear view

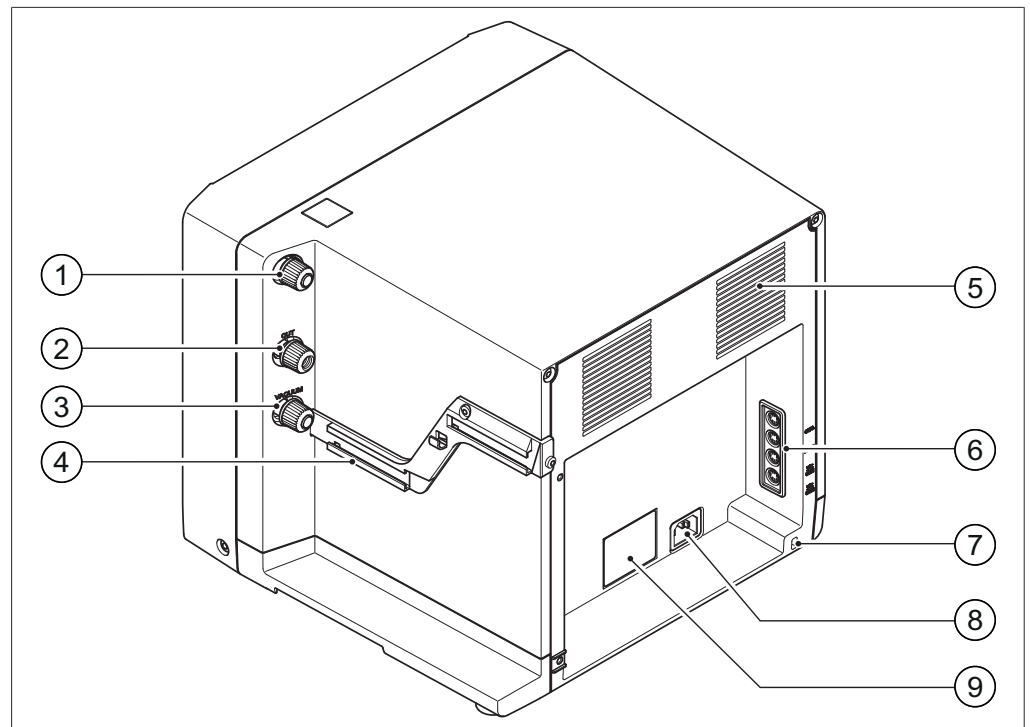

Fig. 2: Rear view of V-600

- |   |  |   |  |
|---|--|---|--|
| 1 | Gas ballast                            | 5 | Ventilation slots  |
| 2 | Pump outlet                            | 6 | Connection panel for communication cables (see Chapter 5.12 "Connecting communication cables to the V-600", page 36) |
| 3 | Pump intake (vacuum)                   | 7 | Lashing eye (for securing against falling during earthquakes)  |
| 4 | Mounting rail for accessory components | 8 | Power supply connection  |
|   |  | 9 | Type plate   |

### 3.3.3 Connections

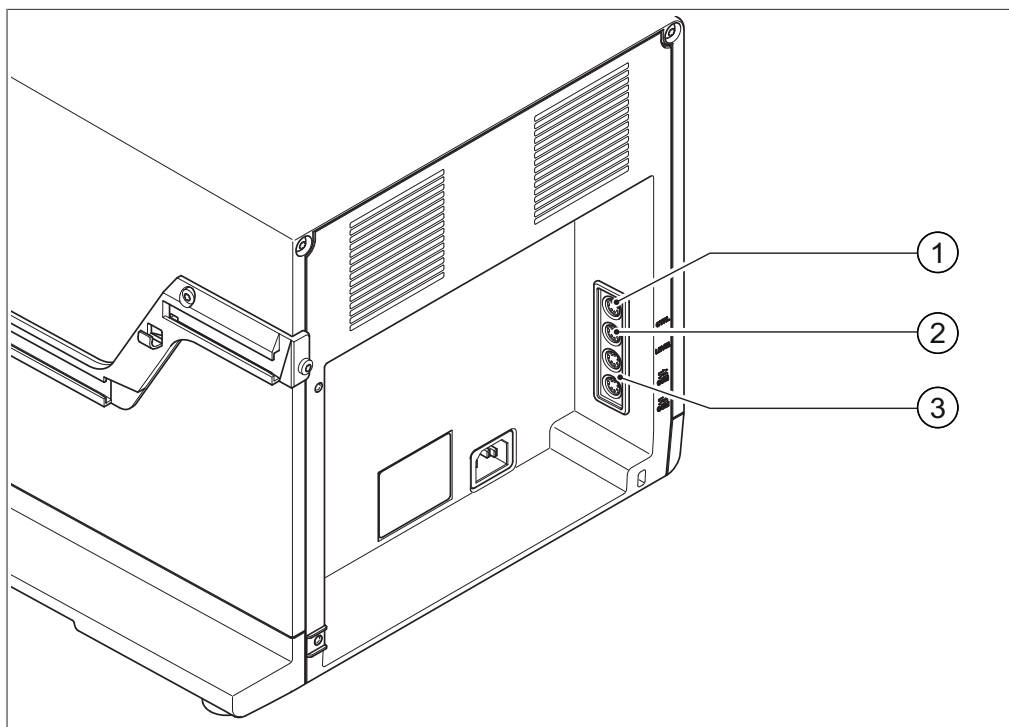

Fig. 3: Connections on the V-600

- |   |   |   |  |
|---|---|---|--|
| 1 | Connection for alternative pump controller (CTRL) | 3 | Standard BUCHI communication ports (COM) |
| 2 | Fill level sensor connection (LEVEL)              |   |  |

#### Standard BUCHI communication port (COM)

The standard BUCHI communication port is used to connect the Interface I-300/I-300 Pro to the Vacuum Pump V-600. For more information, see Chapter 5.13.1 "Overview: Setting up communication connections (COM)", page 38.

#### Connection for alternative pump controllers (CTRL)

The CTRL socket offers the following options:

- Digital ON/OFF control of the pump via legacy devices (V-850 / V-855, V-800 / V-805) or via the VacuBox.
- Operation of two Rotavapor systems with only one Vacuum Pump V-600, see Chapter 5.14 "Operating the Vacuum Pump V-600 with 2 Rotavapor systems", page 41.
- Control of pump speed by different-make products with analog 0– 10 V signal.

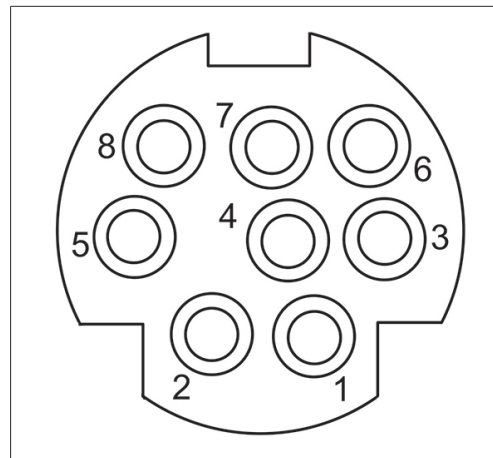

Fig. 4: 8-pin MiniDin pin assignment, view of socket

Pin	Symbol	Description
<b>8-pin notation</b>		
1	DGND	Digital ground
2	Detection DIGIN	Digital input detection
3	nc	not connected
4	AIN 0 – 10 V	Analog Input 0 – 10 V (max. -0.2 V ... 12 V)
5	nc	not connected
6	nc	not connected
7	Detection AIN	Analog input detection
8	DIGIN PWM	Digital input ON/OFF

#### Connection for fill level sensor (LEVEL)

A fill-level sensor can be connected to the Vacuum Pump V-600 as an option. The fill-level sensor measures the fill level of the receiving flask if a secondary condenser or a secondary cold trap is connected to the V-600. If the relevant level is exceeded in the receiving flask, a message appears on the display of the Interface I-300/I-300 Pro.

### 3.3.4 Internal view

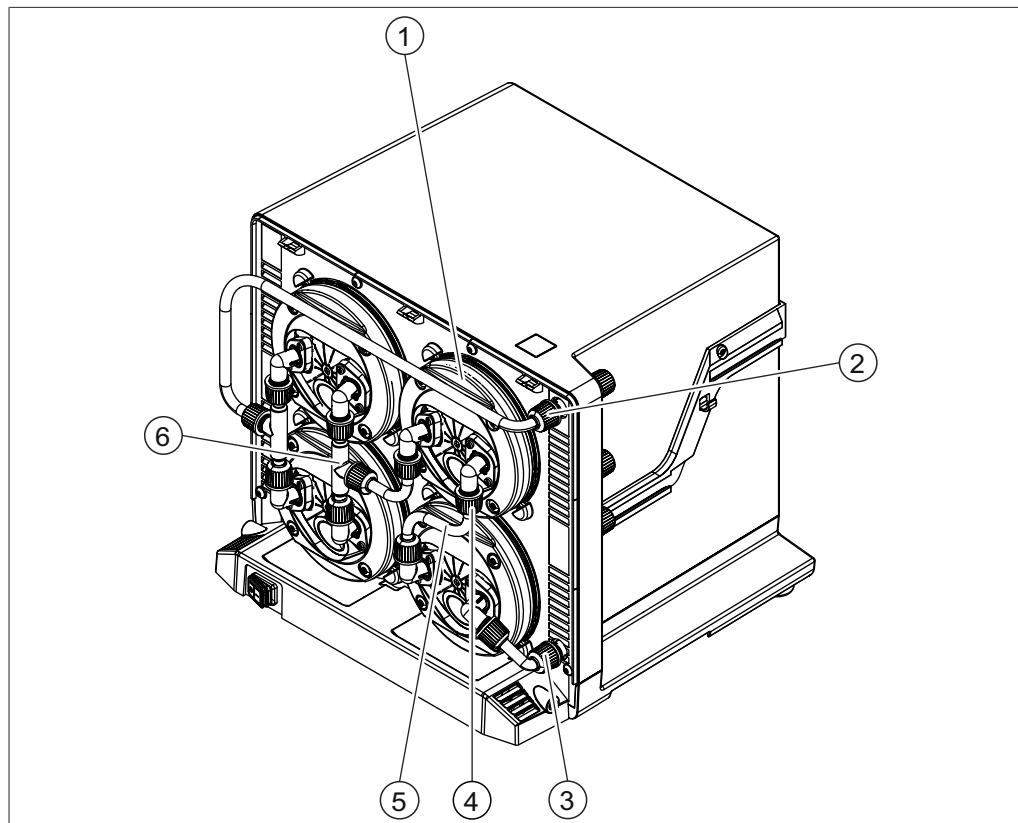

Fig. 5: Internal view of V-600 showing pump heads

- |   |                          |   |                           |
|---|--------------------------|---|---------------------------|
| 1 | Pump head fixing ring    | 4 | GL14 union nut            |
| 2 | Connection (pump intake) | 5 | Pump-head connecting tube |
| 3 | Connection (pump outlet) | 6 | T-piece                   |

### 3.3.5 Type plate

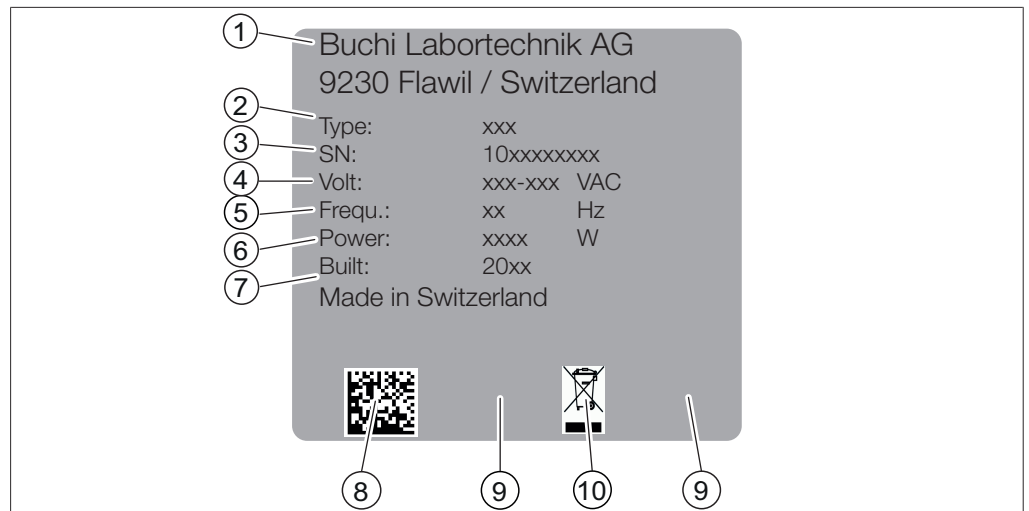

Fig. 6: Type plate

- |   |                          |    |   |
|---|--------------------------|----|---|
| 1 | Company name and address | 2  | Instrument name                                   |
| 3 | Serial number            | 4  | Input voltage range                               |
| 5 | Frequency                | 6  | Power consumption maximum                         |
| 7 | Year of manufacture      | 8  | Product code                                      |
| 9 | Marks and approvals      | 10 | Symbol for "Do not dispose of as household waste" |

### 3.3.6 ATEX supplementary plate



**NOTE**

Identification

Instruments without  mark.

- Instruments without ATEX supplementary plate are not suitable for operation according to ATEX II 3G T3 IIC X.

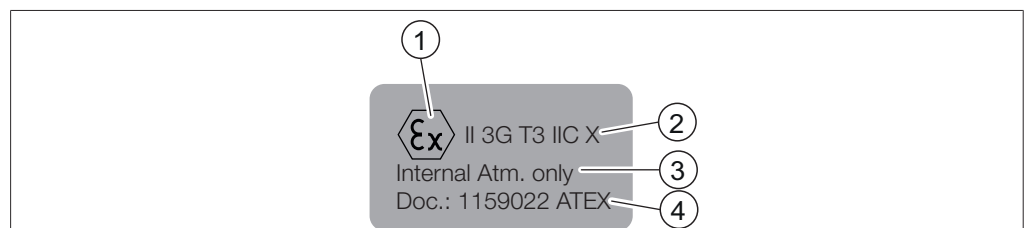

Fig. 7: ATEX supplementary plate

- |   |   |   |   |
|---|---|---|---|
| 1 | ATEX mark   | 2 | ATEX mark   |
| 3 | Note:<br>Only suitable for the area in contact with the fluid inside the vacuum pump. | 4 | Note:<br>For more information refer to the document 1159022 ATEX<br>See Chapter 10.3 "Document: 11594022 ATEX", page 74 |

### 3.4 Specifications supplied

	V-600
<i>[Vacuum Pump V-600]</i>	1
Vacuum tubing (2 m)	1
Power cord	1
Silencer	1
Tubing connections (set)	1
Interface I-300	*
Woulff bottle	*
Secondary cold trap	*
Secondary condenser	*
Communication cables	1
Diaphragm grips	1
Torx key Tx10	1
Torx key Tx25	1

The components marked \* are optional.

### 3.5 Technical data

#### 3.5.1 Vacuum Pump

	<b>Vacuum Pump V-600</b>
Dimensions (W x D x H)	330 x 321 x 291 mm
Weight (without accessories)	13.9 kg
Suction capacity	3.1 m <sup>3</sup> /h
Final vacuum (absolute)	1.5 mbar
Vacuum connection	GL14
Power consumption	360 W
Power consumption, energy saving mode 1 (80%)	190 W
Power consumption, energy saving mode 2 (50%)	120 W
Power supply voltage	100 – 240 VAC
Frequency	50/60 Hz
Maximum speed	1500 rpm
Sound level (depending on operating mode)	40 – 64 dBA
Sound level with 10 % load (normal)	40 dBA
Sound level with 100 % load	64 dBA
Overvoltage category	II
IP Code	IP21
Pollution degree	2
Inlet temperature of media in ATEX 3G T3 IIC X operation mode	< 40 °C
Ignition temperature of media in ATEX 3G T3 IIC X operation mode	> 200 °C
Approvals	CE / CSA / CUS

#### 3.5.2 Ambient conditions

Max. altitude above sea level	2000 m
Ambient temperature	5 - 40 °C
Maximum relative humidity	80 % for temperatures up to 31 °C decreasing linearly to 50 % at 40 °C

The [Vacuum Pump V-600] may only be used in indoor areas.

#### 3.5.3 Materials

<b>Component</b>	<b>Material</b>
Pump heads	PEEK

<b>Component</b>	<b>Material</b>
Drive unit body	Aluminum
Casing	PBT
Diaphragms	EPDM/PTFE
Valve plate	PEEK
Valve body	PEEK
Pump-head connecting tube	FEP
Vacuum tubing	Norprene
Non-return valve O-rings	FKM



## 4 Transport and storage

### 4.1 Transport



#### NOTICE

##### Risk of breakage due to incorrect transportation

- ▶ Make sure that all parts of the device are safely packed in such a way as to prevent breakage, ideally in the original box.
  - ▶ Avoid sharp movements during transit.
- 
- ▶ After transportation, check the device for damage.
  - ▶ Damage that has occurred in transit should be reported to the carrier.
  - ▶ Keep packing for future transportation.

### 4.2 Storage

- ▶ Make sure that the ambient conditions are complied with (see Chapter 3.5 "Technical data", page 19).
- ▶ Wherever possible, store the device in its original packaging.
- ▶ After storage, check the device, all glass components, seals and tubing for damage and replace if necessary.

## 5 Installation

### 5.1 Important considerations prior to commissioning



#### **WARNING**

**Risk of irritation of mucous membranes and poisoning from inhalation of hazardous gases and vapors.**

In the process of evacuation it is possible that hazardous substances may be pumped out at the same time and released into the atmosphere. In addition, it is possible for such substances to collect as condensation at leaking connections.

- ▶ Operate the pump inside a fume hood.
- ▶ Direct vapors from the pump outlet into the fume hood.
- ▶ If necessary, wear a face mask and safety goggles.
- ▶ If necessary, only handle pump and accessories with protective gloves.



#### **WARNING**

**Risk of fire or explosion from flammable solvent vapors.**

In the process of evacuation, it is possible for solvent vapors to get into the area of the pump that does not meet the ATEX II 3G T3 IIC X rating requirements.

- ▶ Clean the vacuum pump according to the instructions.
- ▶ Connect a Woulff bottle upstream of the pump intake.
- ▶ Operate the pump inside a fume hood.



#### **CAUTION**

**Health risks when handling corrosive substances.**

- ▶ When working with strong acids or caustic solutions, always wear personal protective equipment (safety goggles, protective clothing, protective gloves).

## 5.2 Installation site



### NOTICE

#### Risk of property damage from falling equipment (e.g. in an earthquake)

- ▶ Secure the *[Vacuum Pump]* against falling by means of the lashing eye on the rear of the device, see Chapter 3.3.2 "Rear view", page 13.

The installation site must meet the following requirements:

- Firm and level surface: at least 330 mm x 330 mm (W x D)
- Height: at least 300 mm
- Set up inside a fume hood or  
feed the pump outlet into the fume hood
- Sufficient clearance on all sides of the device (approx. 10 cm) in order to ensure air circulation
- Clear air outlet at the rear (ventilation slots must be kept clear)

The *[V-600]* is intended for use in laboratory environments. See Chapter 3.5.2 "Ambient conditions", page 19.

### 5.3 Securing against earthquakes

The Vacuum Pump V-600 has an earthquake fixing to protect the device against falling.

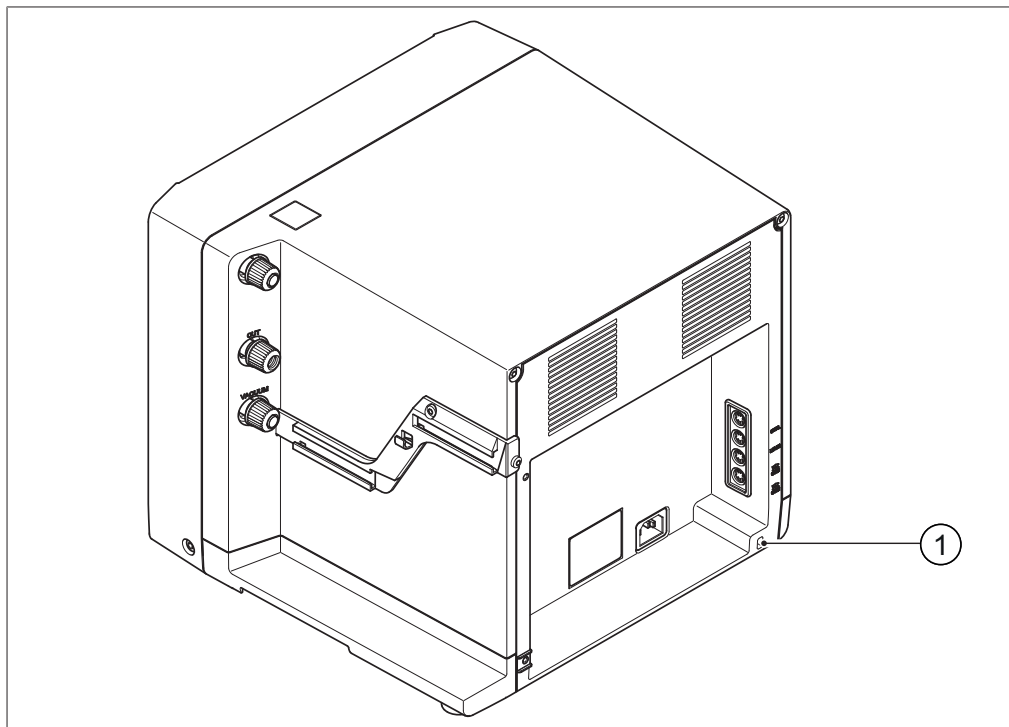

Fig. 8: Lashing eye for securing against falling during earthquakes

1 Lashing eye

- ▶ Thread a strong cord or a wire through the lashing eye (1).
- ▶ Tie the strong cord or a wire to a fixed point.



## 5.5 Connecting the silencer

The silencer can be connected directly to the V-600 or to the outlet of a secondary condenser.

### 5.5.1 Connecting silencer directly to V-600

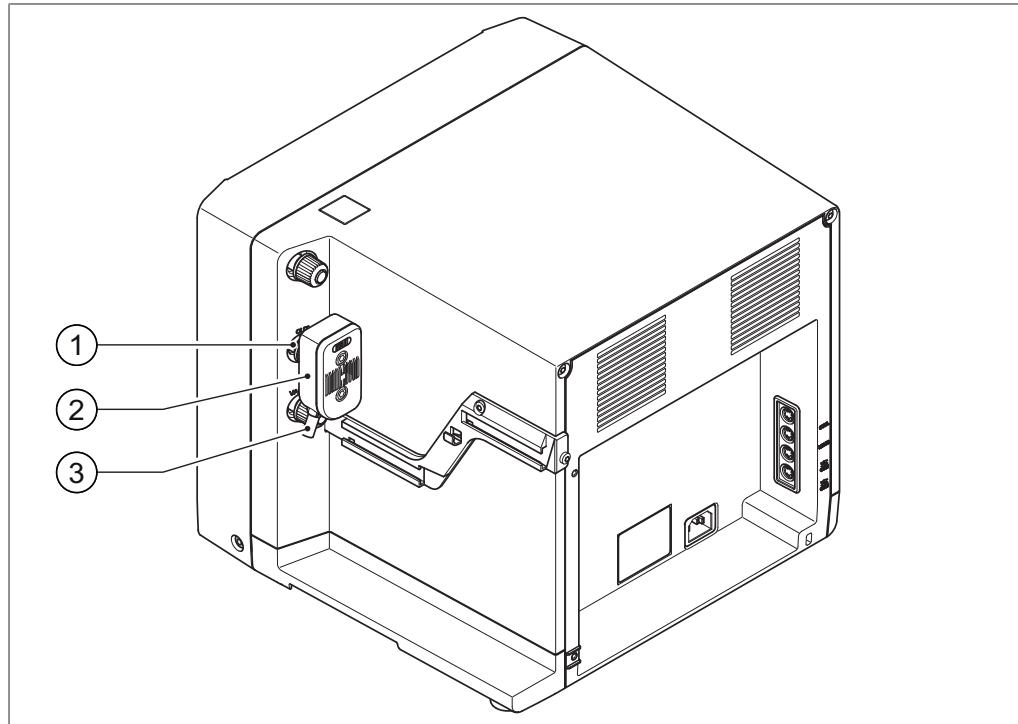

Fig. 10: Silencer on pump outlet of V-600

- |   |                                  |   |                 |
|---|----------------------------------|---|-----------------|
| 1 | GL14 union nut on silencer inlet | 3 | Silencer outlet |
| 2 | Silencer                         |   |                 |

- ▶ Fit the silencer (2) on the pump outlet.
- ▶ Slide the GL14 union nut forward on the silencer inlet (1) and screw it onto the GL14 thread of the pump outlet.



#### NOTE

A tube can be connected to the silencer outlet (3) to direct the exhaust air into a fume hood.

### 5.5.2 Connecting the silencer to the outlet of the secondary condenser

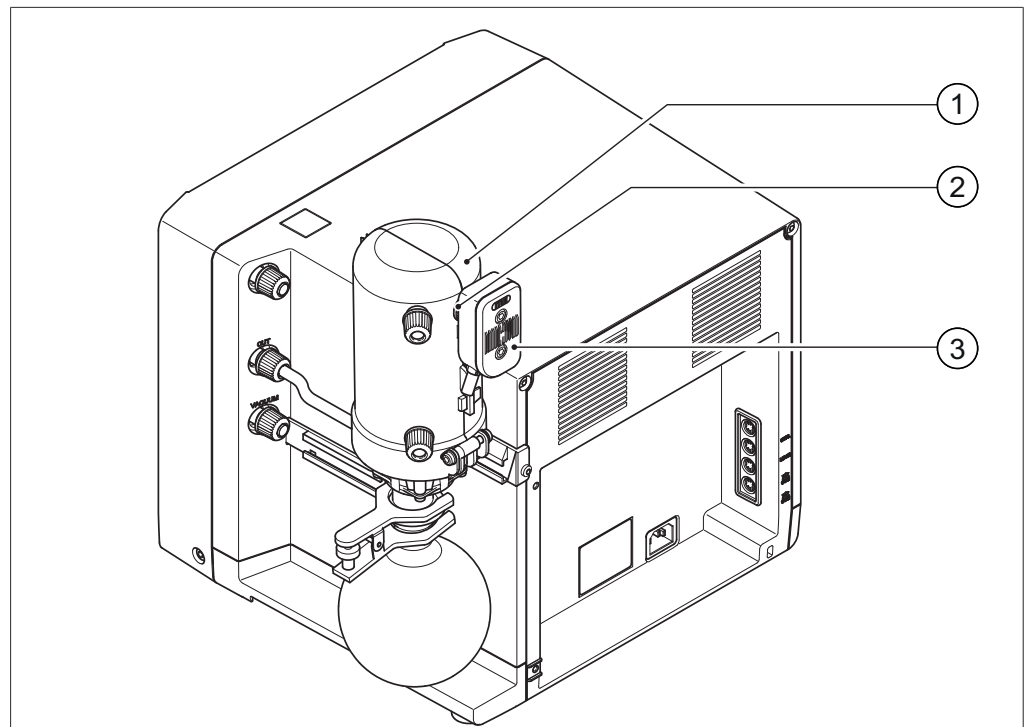

Fig. 11: Silencer on outlet of secondary condenser

- |   |                     |   |          |
|---|---------------------|---|----------|
| 1 | Secondary condenser | 3 | Silencer |
| 2 | GL14 union nut      |   |          |

**Precondition:**

- A secondary condenser (1) is mounted on the pump outlet of the V-600 and connected up, see Connecting a secondary condenser.
- ▶ Fit the silencer (3) on the secondary condenser outlet.
- ▶ Slide the GL14 union nut forward and tube seal on the silencer inlet (2) and screw it onto the GL14 thread of the secondary condenser outlet.

## 5.6 Connecting a Woulff bottle

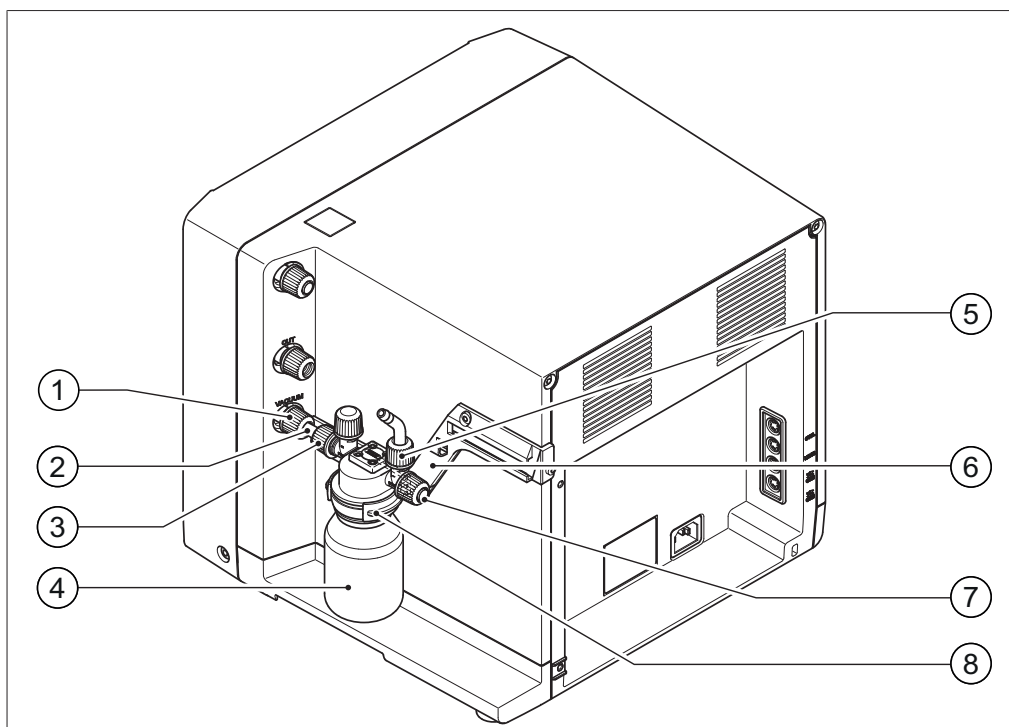

Fig. 12: Woulff bottle on pump inlet of V-600

- |   |                               |   |                               |
|---|-------------------------------|---|-------------------------------|
| 1 | Pump intake (vacuum)          | 5 | Woulff bottle inlet           |
| 2 | Vacuum connecting tube        | 6 | Mounting rail on V-600        |
| 3 | Woulff bottle outlet          | 7 | Outlet for VacuBox connection |
| 4 | Woulff bottle glass component | 8 | Woulff bottle holder          |

The Woulff bottle is fixed to a mounting rail on the V-600 and is connected to the pump intake.

- ▶ Fit the holder (8) around the neck of the Woulff bottle.
- ▶ Fit a short section of vacuum tubing (2) to the outlet of the Woulff bottle (3).
- ▶ Slide a GL14 union nut with tube seal over the unattached end of the vacuum tube.
- ▶ Position the Woulff bottle in front of the pump inlet (1) of the V-600. Slide the holder into the lower slot of the mounting rail (6). When doing so, make sure that the outlet of the Woulff bottle with connecting tube attached is facing the pump inlet.
- ▶ Insert connecting tube (2) in the pump inlet (1) and screw GL14 union nut onto the thread of the pump inlet.

### 5.6.1 Connecting the Vacuobox via a Woulff bottle

If the Vacuum Pump V-600 is to be controlled via an Interface I-300, the Woulff bottle must be connected to the VacuBox by a connecting tube.



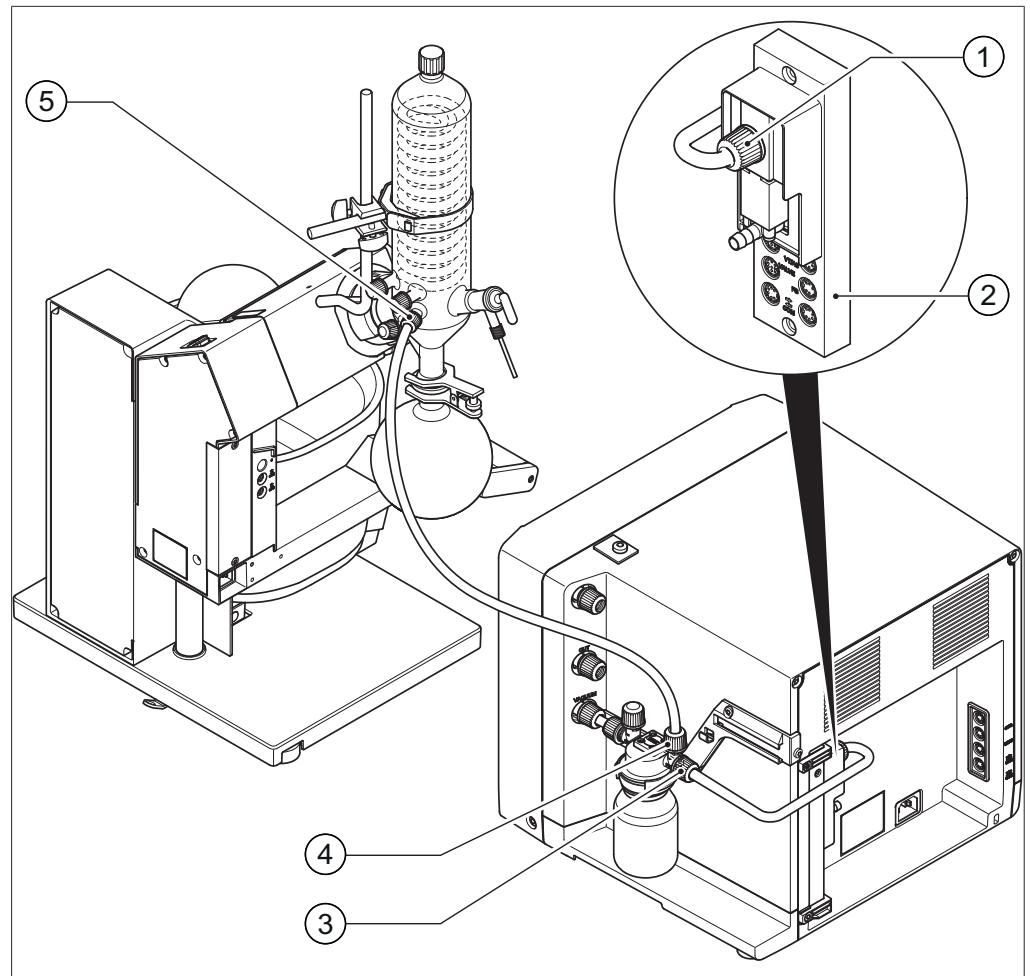

Fig. 13: Woulff bottle tubing connections

- |   |                               |   |   |
|---|-------------------------------|---|---|
| 1 | Vacuum connection on VacuBox  | 4 | Woulff bottle inlet                         |
| 2 | VacuBox                       | 5 | Vacuum connection on cooling con-<br>denser |
| 3 | Outlet for VacuBox connection |   |   |

Precondition:

- Woulff bottle is mounted on and connected to the V-600.
- VacuBox (2) is mounted on the Vacuum Pump V-600, see Chapter 5.10 "Fitting a VacuBox", page 33.
- ▶ Fit a connecting tube to the outlet of the Woulff bottle (3) and the vacuum connection of the VacuBox (1).
- ▶ If necessary, fit a connecting tube to the inlet of the Woulff bottle (4) and the vacuum connection of the cooling condenser (5).

- ▶ Connect the communication cable, see Chapter 5.12 "Connecting communication cables to the V-600", page 36.

**NOTE**

In a BUCHI distillation system, the VacuBox and Woulff bottle can alternatively be mounted on the Rotavapor instead of on the Vacuum Pump V-600. What is important is that the VacuBox and Woulff bottle are as close as possible to each other (on the same device) as otherwise there is a vacuum control lag. If the VacuBox and Woulff bottle are mounted on and connected to the Rotavapor, the relevant sections of the operating instructions for the Rotavapor R-300 must be followed.

## 5.7 Connecting a secondary condenser

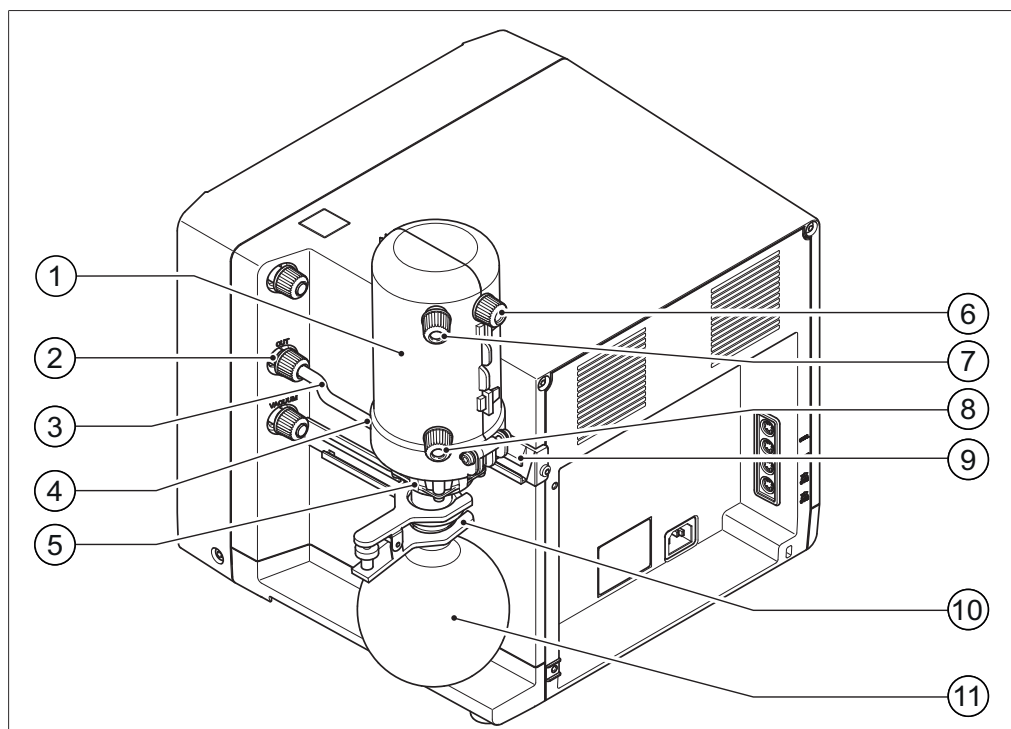

Fig. 14: Secondary condenser connected to pump outlet of V-600

- |   |                                 |    |                        |
|---|---------------------------------|----|------------------------|
| 1 | Secondary condenser             | 7  | Coolant outlet         |
| 2 | Pump outlet with GL14 union nut | 8  | Coolant inlet          |
| 3 | Connecting tube                 | 9  | Mounting rail on V-600 |
| 4 | Secondary condenser inlet       | 10 | Ball joint clamp       |
| 5 | Holder for secondary condenser  | 11 | Receiving flask        |
| 6 | Secondary condenser outlet      |    |                        |

The secondary condenser is fixed to a mounting rail on the V-600 (9) and is connected to the pump outlet (2).

- ▶ Fit a short connecting tube (3) to the secondary condenser inlet (4).
- ▶ Loosely screw a GL14 union nut together with tube seal onto the thread of the pump outlet (2), Chapter 7.2.8 "Fitting GL14 cap nut with tube seal", page 62.  
**NOTICE! If incorrectly fitted, the tube seals may be damaged.**
- ▶ Position the secondary condenser in front of the pump outlet of the V-600. Slide the holder into the upper slot of the mounting rail (7). When doing so, make sure that the inlet of the secondary condenser with connecting tube attached is facing the pump outlet.
- ▶ Insert the connecting tube into the threaded pump outlet connector, taking care not to damage the tube seal when doing so.
- ▶ Tighten the GL14 union nut.
- ▶ Fit receiving flask (11) onto the bottom outlet of the secondary condenser and fix with the aid of a catchpot clip (10).
- ▶ Optional feature: From the outlet of the secondary condenser (6), feed another connecting tube directly into a fume hood.

## 5.8 Connecting a secondary cold trap

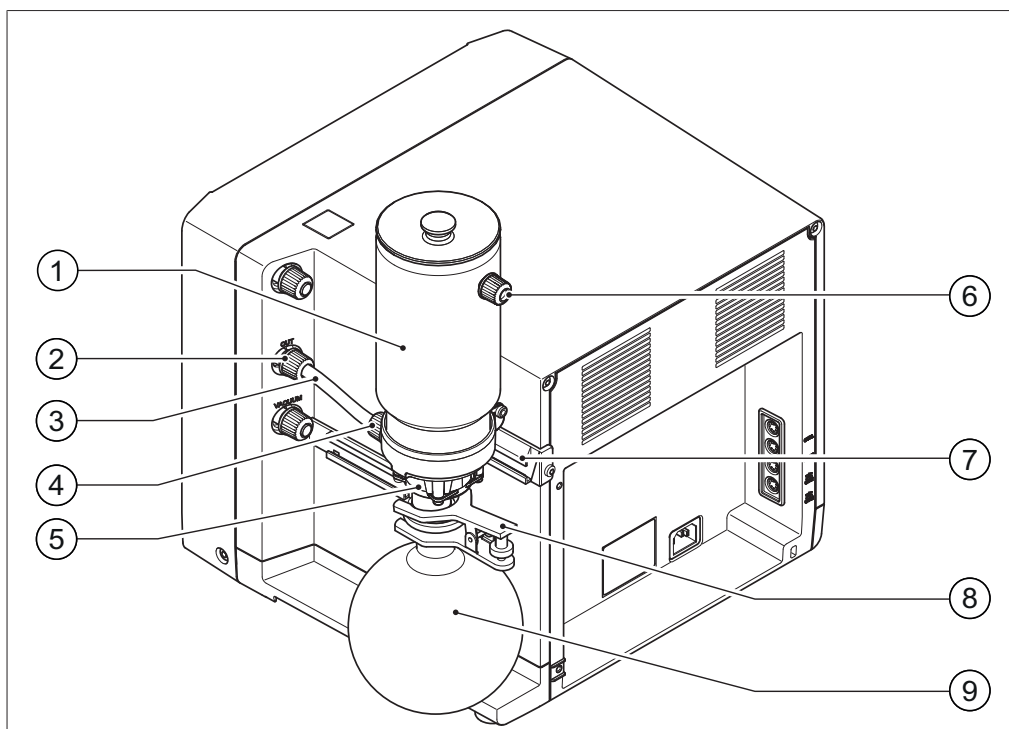

Fig. 15: Secondary cold trap and holder

- |   |                                 |   |                            |
|---|---------------------------------|---|----------------------------|
| 1 | Secondary cold trap             | 6 | Secondary cold trap outlet |
| 2 | Pump outlet with GL14 union nut | 7 | Mounting rail on V-600     |
| 3 | Connecting tube                 | 8 | Ball joint clamp           |
| 4 | Secondary cold trap inlet       | 9 | Receiving flask            |
| 5 | Holder for secondary cold trap  |   |                            |

The secondary cold trap is fixed to a mounting rail on the V-600 in the same way as the secondary condenser (see Chapter 5.7 "Connecting a secondary condenser", page 31) and is connected to the pump outlet.

- ▶ Fit a short connecting tube (3) to the secondary cold trap inlet (4).
- ▶ Loosely screw a GL14 union nut together with tube seal onto the thread of the pump outlet (2), Chapter 7.2.8 "Fitting GL14 cap nut with tube seal", page 62.  
**NOTICE! If incorrectly fitted, the tube seals may be damaged.**
- ▶ Position the secondary cold trap in front of the pump outlet of the V-600. Slide the holder into the upper slot of the mounting rail (7). When doing so, make sure that the inlet of the secondary cold trap with connecting tube attached is facing the pump outlet.
- ▶ Insert the connecting tube into the threaded pump outlet connector, taking care not to damage the tube seal when doing so.
- ▶ Tighten the GL14 union nut.
- ▶ Fit receiving flask (9) onto the bottom outlet of the secondary cold trap and fix with the aid of a ball joint clamp (8).
- ▶ From the outlet (6) of the secondary cold trap, feed another connecting tube directly into a fume hood.

## 5.9 Fitting an Interface I-300

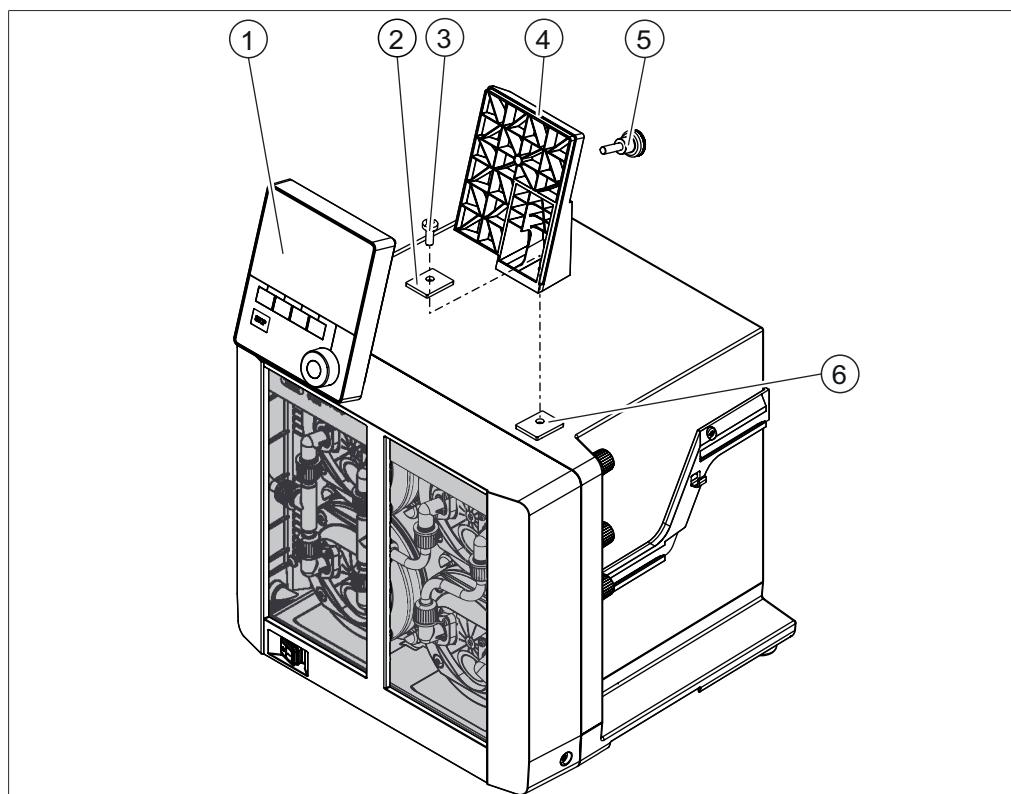

Fig. 16: Holder for fitting the Interface I-300

- |   |                         |   |                               |
|---|-------------------------|---|-------------------------------|
| 1 | Interface I-300         | 4 | Holder                        |
| 2 | Metal plate             | 5 | Knurled-head screw            |
| 3 | Fixing screw for holder | 6 | Rubber plug and threaded hole |

Tools required:

- Torx key Tx25

The Interface I-300 can be mounted on the top of the Vacuum Pump V-600 using a holder.

- ▶ Remove the rubber plug (6) from the top panel of the vacuum pump. Use a screwdriver if necessary.
  - ⇒ Underneath the rubber plug is a threaded hole for a screw.
- ▶ Position the holder (4) over the threaded hole (6) and fix it in place using the screw (3) supplied. When doing so, pass the screw through the hole in the metal plate (2).
- ▶ Feed the communication cable through the holder from the rear and connect it to the COM port on the back of the interface unit.
- ▶ Position the interface unit (1) on the holder and fix it in place using a knurled-head screw (5) inserted from the back.

## 5.10 Fitting a VacuBox

Fitting and connection of a VacuBox to the V-600 are necessary if the pump is to be controlled via an Interface I-300/I-300 Pro. For details, see Chapter 5.13 "Assembling the BUCHI distillation system", page 37.

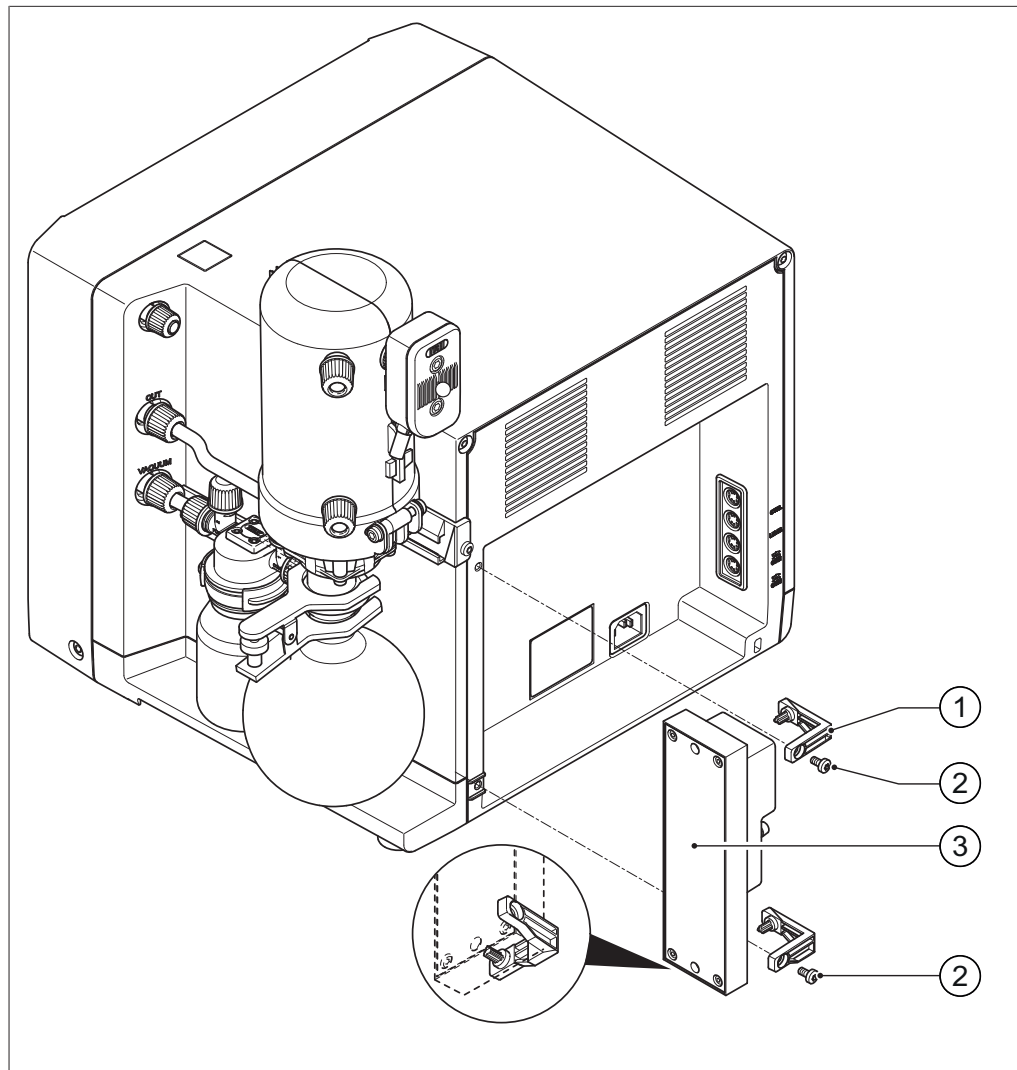

Fig. 17: VacuBox on V-600

- |   |                 |   |         |
|---|-----------------|---|---------|
| 1 | Fixing brackets | 3 | VacuBox |
| 2 | Screws          |   |         |

Tools required:

- Torx key Tx10

- ▶ Press fixing brackets (1) into the holes in the top and bottom of the VacuBox. The wider of the two fixing brackets has to be fitted at the bottom.
- ▶ Position the VacuBox (3) on the rear of the V-600 on the left inner face of the recess.
- ▶ Fix each fixing bracket to the casing of the V-600 with a screw (2).



**NOTE**

If a VacuBox is fitted, a Woulff bottle is a compulsory requirement.

## 5.11 Connecting the vacuum pump to the power supply

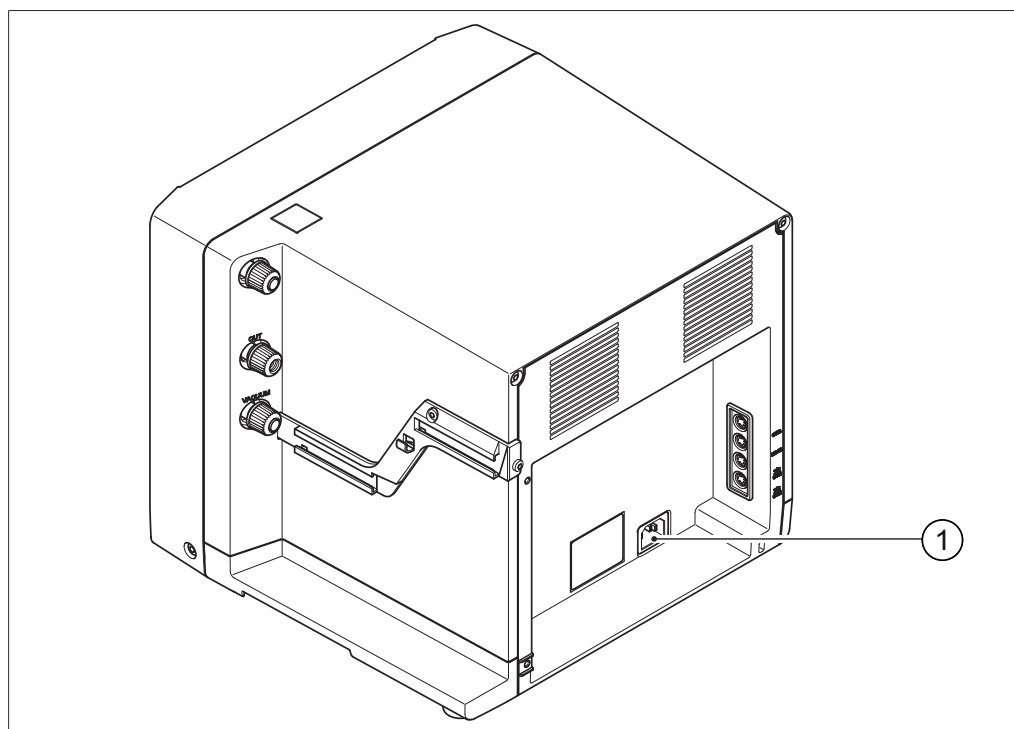

Fig. 18: Electrical connections on the V-600

1 Power supply connection

- ▶ Plug the power cord into the power supply socket (1) on the pump and then into a mains power socket. Make sure that the available power supply matches the rating indicated on the type plate.

## 5.12 Connecting communication cables to the V-600

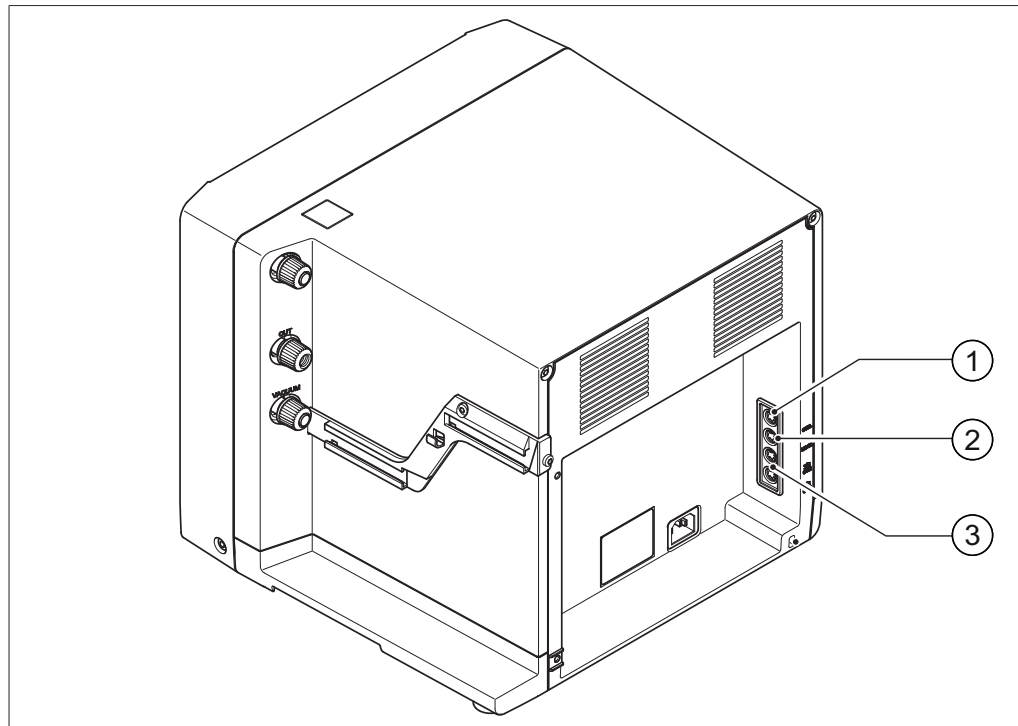

Fig. 19: Communication connections on V-600

- |   |   |   |  |
|---|---|---|--|
| 1 | Connection for alternative pump controller (CTRL) | 3 | Standard BUCHI communication ports (COM) |
| 2 | Fill level sensor connection (LEVEL)              |   |  |
- ▶ Plug the communication cable for connection to other BUCHI laboratory equipment into one of the two standard BUCHI communication ports (3).
  - ▶ Plug the communication cable into the green communication port on the other item of laboratory equipment. For details of connecting the equipment via the communication ports see Chapter 5.13.1 "Overview: Setting up communication connections (COM)", page 38.



## 5.13 Assembling the BUCHI distillation system

In order to use the *[Vacuum Pump]* to best effect, we recommend that it is used together with the following equipment:

The F-3xx is a recirculating chiller with a sealed circulation system. It is available in various capacity ratings.

The Interface I-300/I-300 Pro together with the VacuBox can be used to control and monitor the vacuum. It can control the Rotavapor, the Vacuum Pump V-300/V-600 and the Recirculating Chiller F-3xx.

The Vacuum Pump V-300/V-600 is a diaphragm pump designed for evacuating laboratory apparatus. It can be operated either as a standalone device or combined with optional accessories such as an interface unit and a secondary condenser to form a complete vacuum system. The laboratory equipment to be evacuated is connected to the vacuum pump and the VacuBox by means of vacuum tubing. See Chapter 5.13.3 "Overview: setting up vacuum tubing connections", page 40.

Data communication between the laboratory equipment takes place via the communication ports. See Chapter 5.13.1 "Overview: Setting up communication connections (COM)", page 38.

The coolant circulates around the distillation system through a separate circulation system. See Chapter 5.13.2 "Overview: setting up coolant tubing connections", page 39.

### 5.13.1 Overview: Setting up communication connections (COM)

The laboratory apparatus can be connected in any order.

As well as the interface unit, a VacuBox also has to be connected.

Below is an example of the connections between the laboratory apparatus.

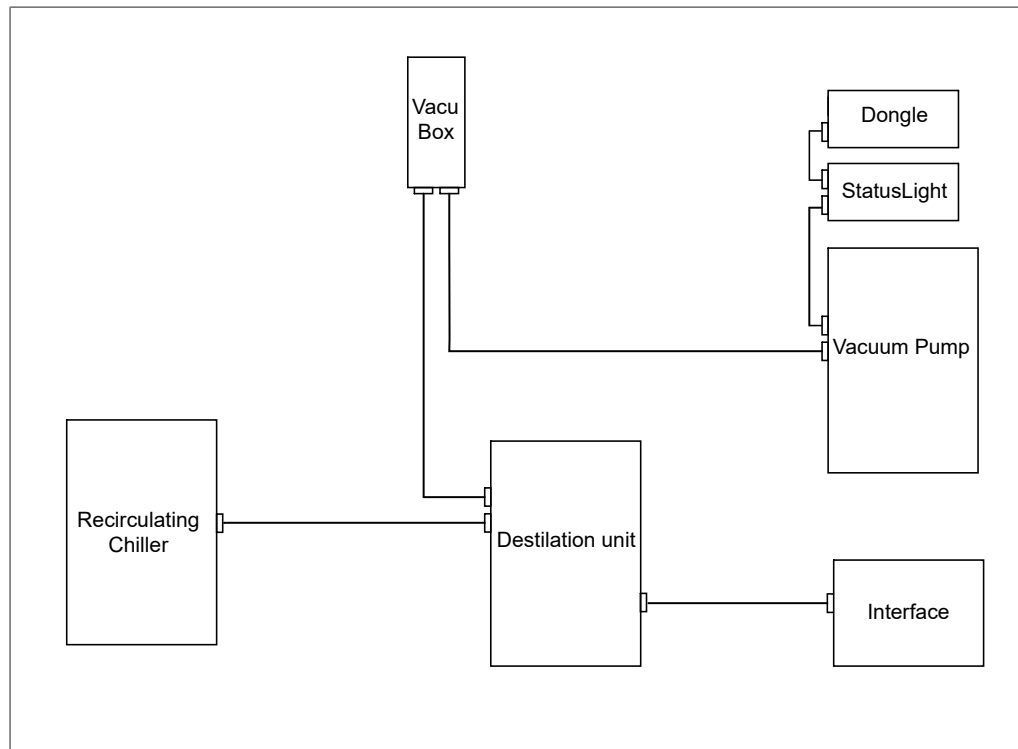

Fig. 20: Schematic diagram of communication connections between the BUCHI laboratory equipment (example)

### 5.13.2 Overview: setting up coolant tubing connections

The tubing connections between the various items of BUCHI laboratory equipment form a sealed circulation system. The starting and finishing point is always the recirculating chiller (F-3xx).

Below is an example of the tubing connections between the laboratory apparatus.

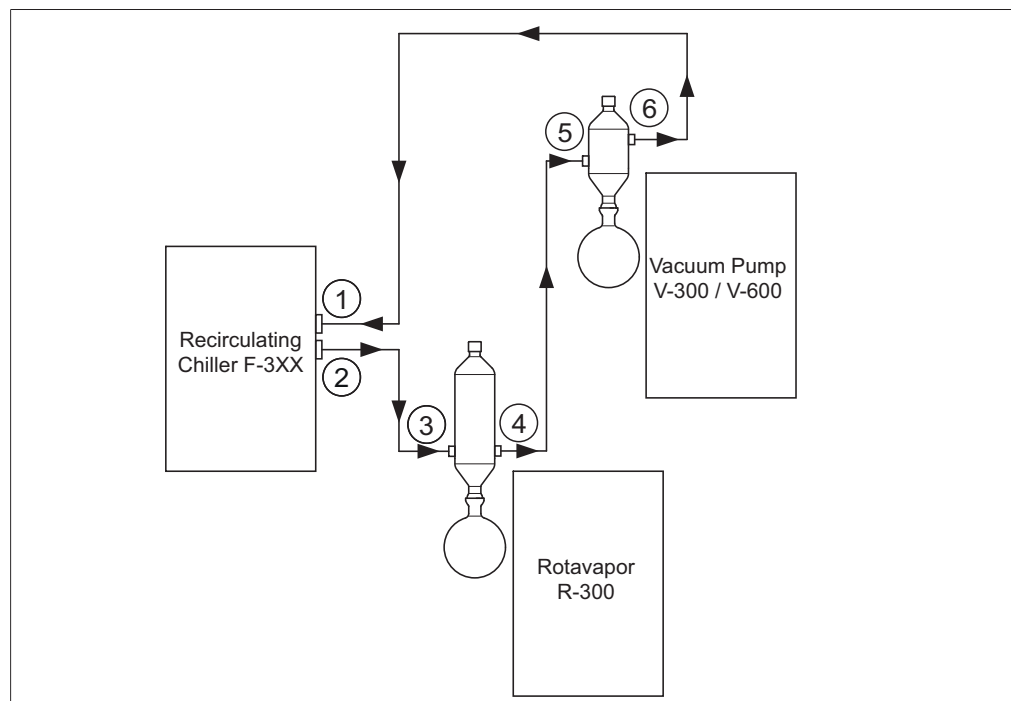

Fig. 21: Coolant tubing connections in a BUCHI distillation system (example)

- |   |                                       |   |   |
|---|---------------------------------------|---|---|
| 1 | Inlet on Recirculating Chiller F-3xx  | 4 | Condenser outlet on Rotavapor R-300                   |
| 2 | Outlet on Recirculating Chiller F-3xx | 5 | Secondary condenser inlet on Vacuum Pump V-300/V-600  |
| 3 | Condenser inlet on Rotavapor R-300    | 6 | Secondary condenser outlet on Vacuum Pump V-300/V-600 |

- ▶ Connect a tube between the outlet of the recirculating chiller (2) and the inlet of the condenser on the Rotavapor R-300 (3).
- ▶ Connect a tube between the outlet of the condenser on the Rotavapor R-300 (4) and the inlet of the secondary condenser on the Vacuum Pump V-300/V-600 (5).
- ▶ Connect a tube between the outlet of the secondary condenser on the Vacuum Pump V-300/V-600 (6) and the inlet of the recirculating chiller (1).



#### NOTE

Use GL14 hose barbs for the tubing connections.

Secure tubes with spring clips where necessary.

### 5.13.3 Overview: setting up vacuum tubing connections

The vacuum tubing connections in a typical BUCHI distillation system lead from the Rotavapor R-300 via a Woulff bottle to the Vacuum Pump V-300/V-600. The vacuum is measured by means of the VacuBox, which is also connected to the Woulff bottle.

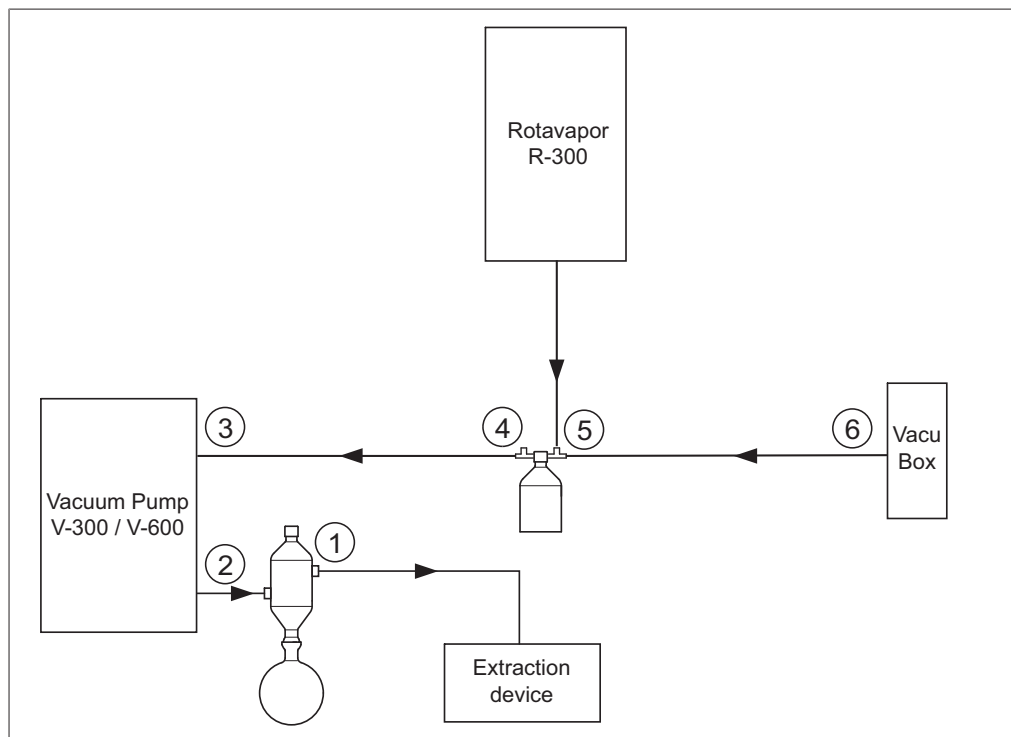

Fig. 22: Coolant tubing connections in a BUCHI distillation system

1	Secondary condenser outlet	4	Woulff bottle outlet (PUMP)
2	Vacuum Pump V-300/V-600 outlet	5	Woulff bottle inlet (CONTR)
3	Vacuum Pump V-300/V-600 inlet	6	VacuBox vacuum connection

- ▶ Connect a tube between the Rotavapor R-300 and the top inlet of the Woulff bottle.
- ▶ Connect a tube between the outlet of the Woulff bottle marked PUMP (4) and the pump inlet (3).
- ▶ Connect the secondary condenser to the pump outlet (2).
- ▶ For measuring and controlling the vacuum, connect a tube between the inlet of the Woulff bottle marked CONTR (5) and the VacuBox (6).

The pressure is measured in the VacuBox. The current working pressure can be indicated and controlled by means of the Interface I-300/I-300 Pro.



#### NOTE

The VacuBox and Woulff bottle can be mounted either on the Rotavapor R-300 or the Vacuum Pump V-300/V-600. What is important is that the VacuBox and Woulff bottle are as close as possible to each other (on the same device) as otherwise there is a vacuum control lag.

## 5.14 Operating the Vacuum Pump V-600 with 2 Rotavapor systems

It is possible to simultaneously operate 2 Rotavapor systems with only one Vacuum Pump V-600. This involves using the alternative pump control connection (CTRL) on the V-600, see Chapter 3.3.3 "Connections", page 14.



### NOTE

The pump speed is then no longer controlled.

The following equipment and accessories are required:

- 2x Rotavapor
- 2x Interface I-300/I-300 Pro
- 2x Valve unit
- 2x VacuBox
- 1x Y-cable
- 2x Standard BUCHI communication cable
- 1x Vacuum Pump V-600
- If an R-300 is not used: 2x mains adaptor and lead

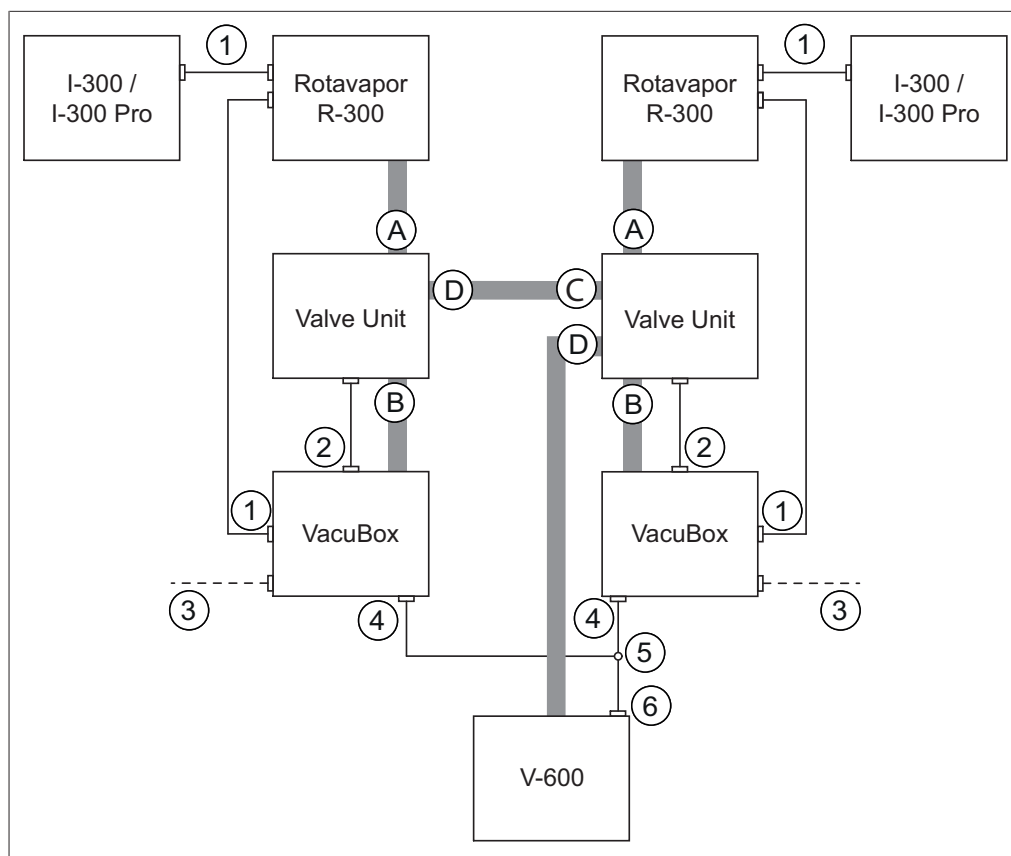

Fig. 23: Schematic diagram of connections when using 2 Rotavapor systems

- |   |  |   |                             |
|---|--|---|-----------------------------|
| 1 | Standard BUCHI communication ports (COM)                   | A | Woulff bottle inlet (1)     |
| 2 | Connection for valve unit (VALVE)                          | B | Woulff bottle inlet (CONTR) |
| 3 | Optional feature: Mains adaptor and lead                   | C | Woulff bottle inlet (2)     |
| 4 | Connection for Y cable on VacuBox (CW)                     | D | Woulff bottle outlet (PUMP) |
| 5 | Y cable (8-pin MiniDIN CTRL)                               |   |                             |
| 6 | Connection for alternative pump controller (CTRL) on V-600 |   |                             |
- ▶ Connect up each set of 1 Rotavapor R-300, 1 Interface I-300/I-300 Pro and 1 VacuBox via the standard BUCHI communication ports (1).
  - ▶ Connect vacuum tubing from each valve unit to one Rotavapor R-300 and one VacuBox. To do so, use the CONTR inlets (B) for the Woulff bottle.
  - ▶ Connect each valve unit to one VacuBox using the connection marked VALVE (2).
  - ▶ Connect a tube between the two valve units. To do so, use the outlets (PUMP) for the Woulff bottle.
  - ▶ Plug a Y cable (5) into the CW connections (4) of the two VacuBoxes and connect it to the Vacuum Pump V-600 using the CTRL connection (5).
  - ▶ Connect a tube between one valve unit and the Vacuum Pump V-600. Use the connection marked PUMP on the valve unit for this purpose.

- ▶ If a Rotavapor R-300 is not used, connect each VacuBox to the external power supply by means of a mains adaptor (3).

## 6 Operation



### CAUTION

#### **Risk of implosion of damaged glass components**

Risk of injury from glass splinters and escaping fluids

- ▶ Always inspect all glass components for damage every time they are to be used.



### CAUTION

#### **Risk of explosion caused by residues of previously used fluids in the vacuum system.**

- ▶ Always clean the vacuum pump according to the instructions before any change of fluid.



### CAUTION

#### **Potential danger of inactive cooling during distillation**

Risk of burns if solvent vapors are ignited

- ▶ Always monitor the function of the cooling system.

### 6.1 Operating V-600 without Interface I-300/I-300 Pro

If not controlled by an Interface I-300/I-300 Pro, the Vacuum Pump V-600 runs in continuous mode and switches to energy saving mode after one hour, see Chapter 3.1 "Description of function", page 11.

- ▶ To start the pump, switch on the master switch on the front of the V-600.

### 6.2 Operating V-600 with Interface I-300/I-300 Pro

The Vacuum Pump V-600 can also be externally controlled by an Interface I-300/I-300 Pro. Control encompasses the following parameters and functions:

- Setting the required vacuum
- Timer

More information on overall control of distillation processes comprising the V-600 and other laboratory equipment can be found in the operating instructions for the Interface I-300/I-300 Pro.



## 7 Cleaning and servicing



### NOTE

Users may only carry out the servicing and cleaning operations described in this section.

Any servicing and repair work which involves opening up more than the casing front may only be carried out by authorized service technicians.

- ▶ Use only genuine BUCHI consumables and spare parts in order to ensure correct operation of the device and preserve the warranty.
- ▶ Before carrying out any servicing work, switch off the device and disconnect it from the power cable.

### 7.1 Cleaning

#### 7.1.1 Important considerations when cleaning



#### **WARNING**

##### **Risk of fatal injury from electric shock.**

If the pump is opened up while it is running there is a risk of dangerous electric shocks.

- ▶ Before carrying out any cleaning or servicing work, always shut down the device and disconnect the power cable.



#### **WARNING**

##### **Creation of sparks by foreign particles in the vacuum system.**

The instrument is not suitable for operation according to ATEX II 3G T3 IIC X.

- ▶ Make sure that no foreign particles get into the vacuum system during cleaning and maintenance work.



#### **WARNING**

##### **Risk of flammable atmosphere if vacuum system is not sealed.**

The instrument is not suitable for operation according to ATEX II 3G T3 IIC X.

- ▶ Make sure that the vacuum system is sealed after cleaning and maintenance work.

#### 7.1.2 Cleaning the pump

The pump only needs to be cleaned if the terminal vacuum is no longer achieved, dirt is visible through the inspection window or after using certain chemicals. Daily cleaning of the pump is not necessary.

- ▶ Detach tubing connections to other laboratory equipment.

- ▶ If present, remove Woulff bottle from pump intake and secondary condenser or cold trap from pump outlet and clean them.
- ▶ Hold several paper towels in front of the pump outlet.
- ▶ Switch on the Vacuum Pump V-600 and allow it to run.
- ▶ Spray 5 to 10 mL of acetone or ethanol into the pump intake.
- ▶ Hold your finger over the pump intake for a short time so that a vacuum is created.
- ▶ Remove your finger from the pump intake again.
- ▶ Allow the pump to run until there is no more liquid inside the pump heads.
- ▶ If necessary, repeat the process of flushing with acetone/ethanol and evacuating.
- ▶ Switch off the pump and reconnect the tubing.

**NOTE**

If the procedure described above is insufficient, carry out the following steps:

- ▶ Clean the casing, see Chapter 7.1.3 "Cleaning the casing", page 46.
- ▶ Clean the glass components, see Chapter 7.1.4 "Cleaning glass components", page 46.
- ▶ Clean the tubing, see Chapter 7.1.5 "Cleaning internal pump tubing", page 47.
- ▶ Clean the diaphragms, see Chapter 7.1.6 "Cleaning the diaphragm", page 47.

### 7.1.3 Cleaning the casing



#### NOTICE

##### Risk of acid damage

The casing of the unit is made of plastic. Acid may damage the material.

- ▶ Immediately remove any drops of acid with a damp cloth.

- ▶ Use a damp cloth to clean the device.
- ▶ To clean the casing, only use ethanol or soapy water.

### 7.1.4 Cleaning glass components

On the front of the V-600 there is an inspection window made of glass. That inspection window may mist over or become dirty from vapors.

- ▶ Remove the casing front, see Chapter 7.2.2 "Dismantling and reassembling pump head", page 49.
- ▶ Rinse inspection window in front cover with water and a conventional cleaning agent (e.g. mild soap and water solution).
- ▶ Wipe inspection window dry with a cloth.
- ▶ Refit front cover and screw in place.

The accessories (Woulff bottle, secondary cold trap, secondary condenser) consist mainly of glass and must always be inspected before and after use and cleaned as necessary.

As the glass components are under vacuum when in use, they are subjected to high stress.

- ▶ Secondary cold trap and secondary condenser: disconnect all tubing and remove from the vacuum pump.

- ▶ Woulff bottle: unscrew the glass part from the holder.
- ▶ Check the glass components for cracks, chips and other signs of damage.
- ▶ Replace any damaged glass components.
- ▶ Rinse out glass components with water and a conventional cleaning agent (e.g. mild soap and water solution).
- ▶ Wherever possible, clean glass components by hand.

**NOTE**

Inserting a thin copper wire into the coil of the secondary condenser reduces algae growth.

### 7.1.5 Cleaning internal pump tubing

After evacuation, there may still be residual fluid from condensed vapors in the tubing inside the pump. The pump can largely dry itself out when running idle. See Chapter 7.1.2 "Cleaning the pump", page 45.

To clean the connecting tubing inside the pump between the two pump heads it is necessary to open up the pump.

Precondition:

- Pump has been shut down.

- ▶ Remove the casing front and take out the pump-head connecting tube (see Chapter 7.2.5 "Replacing connecting tubes", page 57).
- ▶ Rinse out the pump-head connecting tube with acetone. If necessary, remove residues inside the tubing with a suitable implement.
- ▶ Refit the pump-head connecting tube (see Chapter 7.2.5 "Replacing connecting tubes", page 57).
- ▶ Refit the casing front.
- ▶ Switch on the pump and allow it to run in continuous mode until the inside of the tubing is dried out.

### 7.1.6 Cleaning the diaphragm

- ▶ Remove the diaphragm, see Replacing the diaphragm.
- ▶ Clean the diaphragm with a cloth and a little acetone.

## 7.2 Servicing

### 7.2.1 Notes on servicing

**⚠ WARNING**

**Risk of fatal injury from electric shock.**

If the pump is opened up while it is running there is a risk of dangerous electric shocks.

- ▶ Before carrying out any cleaning or servicing work, always shut down the device and disconnect the power cable.



## NOTICE

### **Risk of pump damage and loss of warranty entitlement.**

Unauthorized opening up of any casing components apart from the front casing may permanently impair the function of the pump.

- ▶ Only allow authorized BUCHI service technicians to open up the rear part of the pump.



## WARNING

### **Creation of sparks by foreign particles in the vacuum system.**

The instrument is not suitable for operation according to ATEX II 3G T3 IIC X.

- ▶ Make sure that no foreign particles get into the vacuum system during cleaning and maintenance work.



## WARNING

### **Risk of flammable atmosphere if vacuum system is not sealed.**

The instrument is not suitable for operation according to ATEX II 3G T3 IIC X.

- ▶ Make sure that the vacuum system is sealed after cleaning and maintenance work.

### 7.2.2 Dismantling and reassembling pump head

The four pump heads and the connecting parts (T-pieces and pump-head connecting tubes) are located behind the front casing (1).

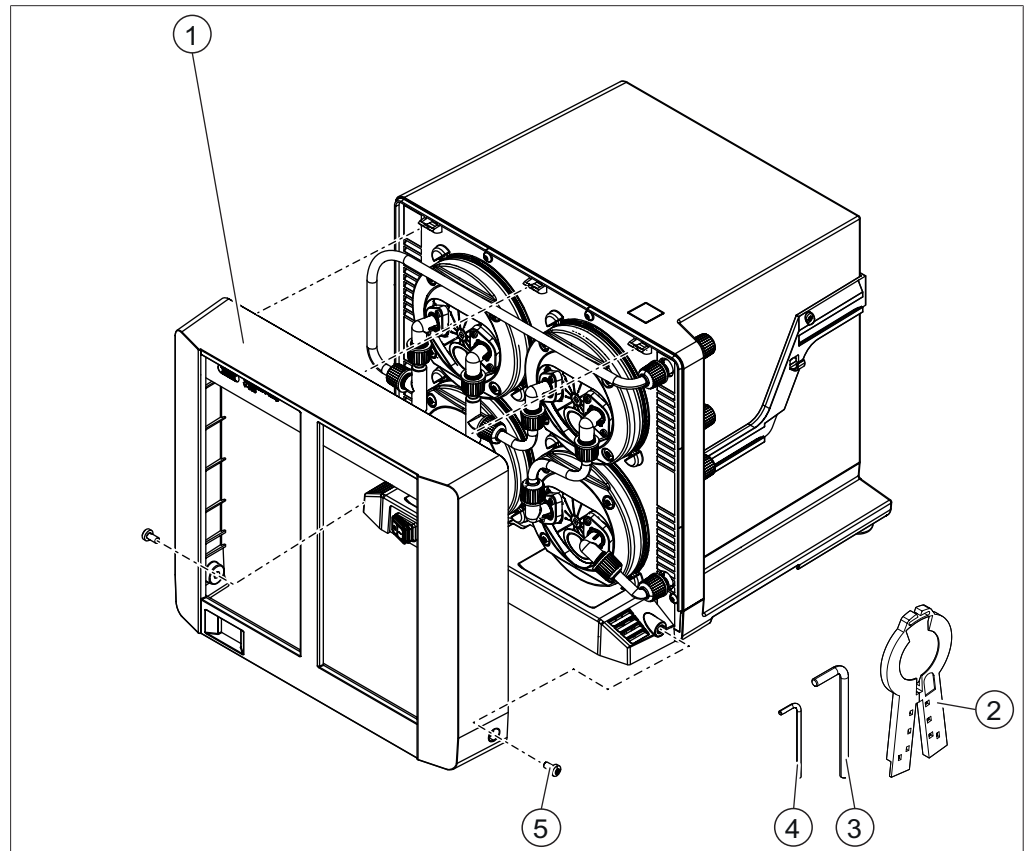

Fig. 24: Front casing of V-600

- |   |                            |   |                          |
|---|----------------------------|---|--------------------------|
| 1 | Front casing               | 4 | Torx key Tx10 (supplied) |
| 2 | Diaphragm grips (supplied) | 5 | Fixing screws            |
| 3 | Torx key Tx25 (supplied)   |   |                          |

Tools required:

- Torx key Tx25

Precondition:

- Pump has been shut down.
- Connections between the pump and other laboratory equipment have been disconnected.
- ▶ Using a Torx key (3), unscrew the two fixing screws (5) at the sides.
- ▶ Remove front casing (1).

### Step 1: Removing connecting components

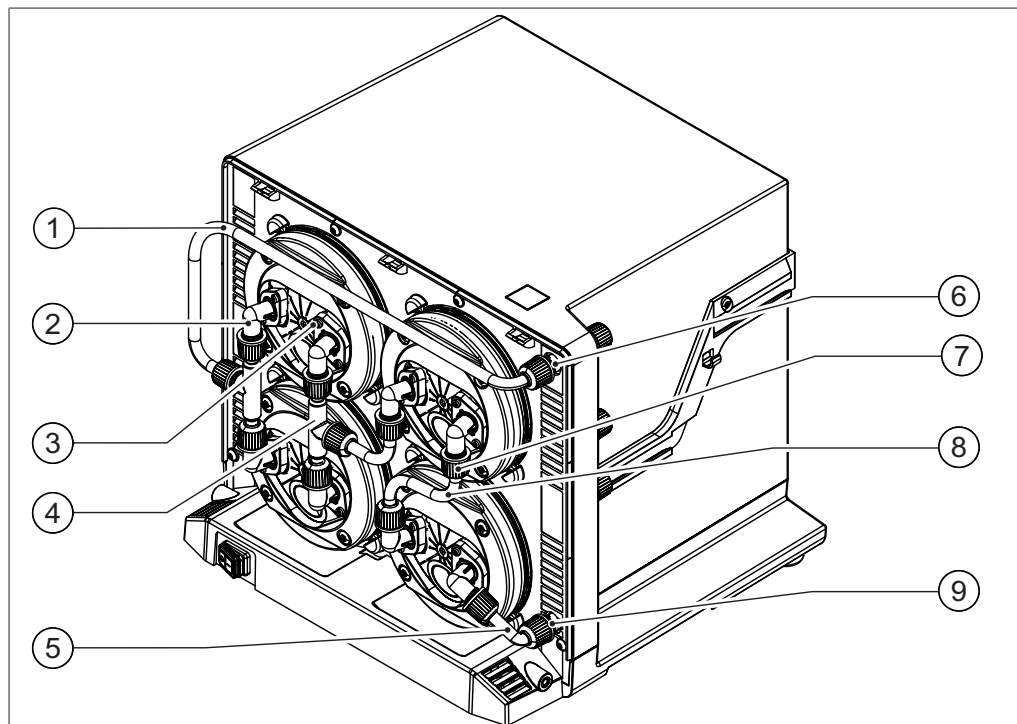

Fig. 25: Elbow connectors, connecting tubes and T-pieces inside V-600

- |   |  |   |                            |
|---|--|---|----------------------------|
| 1 | Connecting tube between pump head and pump intake connection | 6 | Connection for pump intake |
| 2 | Elbow connector  | 7 | GL14 union nut             |
| 3 | Fixing screw for connector                                   | 8 | Pump-head connecting tube  |
| 4 | T-piece  | 9 | Connection for pump outlet |
| 5 | Connecting tube between pump head and pump outlet connection |   |                            |

The V-600 has four pump-head connecting components as follows:

- Connecting tube (1) and T-piece between left-hand pump heads and pump intake connection
- Connecting tube and T-piece (4) between left-hand pump heads and right upper pump head
- Connecting tube (8) between right upper pump head and right lower pump head
- Connecting tube (5) between right lower pump head and pump outlet connection

#### Removing connecting components between left-hand pump heads and pump intake connection

Tools required:

- Torx key Tx10
- ▶ Unscrew the fixing screws (3) from the two elbow connectors (2) on the left-hand pump heads.
- ▶ Unscrew and pull back the GL14 union nut on the connection for the pump intake (6).

- ▶ Remove the entire connecting component together with elbow connectors.

### Removing connecting component between right-hand pump head and pump intake connection

Tools required:

- Torx key Tx10
- ▶ Unscrew the fixing screws (3) for the elbow connector (2) on the pump head.
- ▶ Unscrew and pull back the GL14 union nut on the connection for the pump outlet (9).
- ▶ Remove the entire connecting component together with elbow connector.

### Removing connecting component between left and right-hand pump heads

Tools required:

- Torx key Tx10
- ▶ Unscrew the fixing screws (3) of the elbow connectors (2) on the left-hand pump heads and the elbow connector on the right-hand upper pump head.
- ▶ Remove the three elbow connectors including the entire connecting component.

### Removing connecting tube between the two right-hand pump heads

Tools required:

- Torx key Tx10
- ▶ Unscrew the fixing screws (3) from the two elbow connectors (2).
- ▶ Remove the two elbow connectors together with the connecting tube.

## Step 2: dismantling pump head

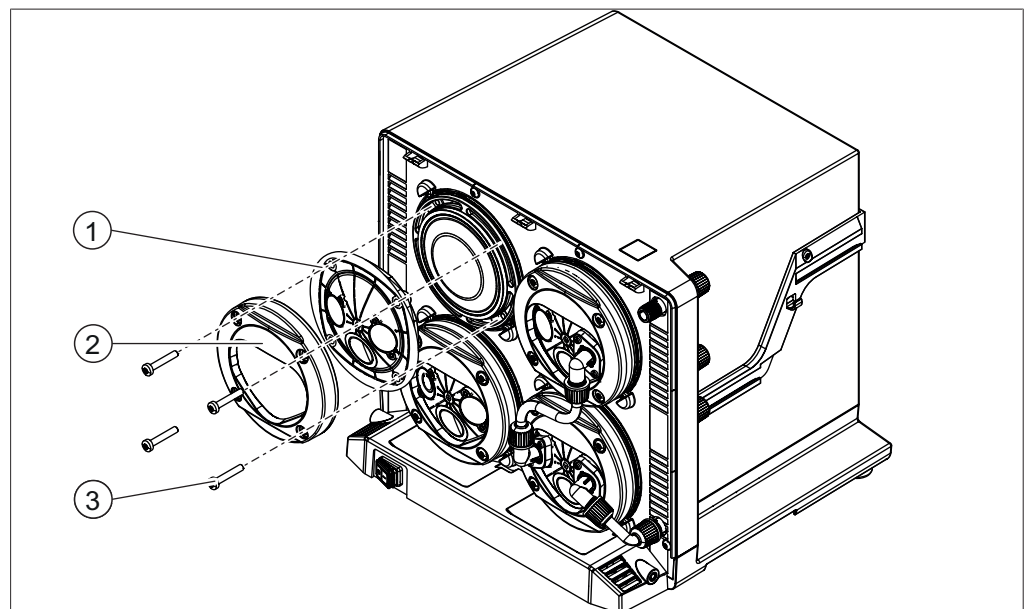

Fig. 26: Pump heads and diaphragms of V-600

- |   |             |   |                  |
|---|-------------|---|------------------|
| 1 | Pump head   | 3 | Torx-head screws |
| 2 | Fixing ring |   |                  |

Tools required:

- Torx key Tx25
- ▶ Using a Torx key, unscrew the four Torx-head screws (3).
- ▶ Remove the fixing ring (2) and pump head (1).
- ⇒ Behind the pump head is the pump diaphragm. To replace the diaphragm, see Chapter 7.2.3 "Replacing the diaphragm", page 53.

### **Step 3: Reassembling and refitting the pump head**

- ▶ Fit the pump head over the diaphragm.
- ▶ Position the fixing ring on the pump head and fix in place with four Torx-head screws.
- ▶ Refit the connecting components between the pump heads.
- ▶ Refit the connecting component between pump head and pump intake or outlet connection.
- ▶ Refit casing front.



### 7.2.3 Replacing the diaphragm

Diaphragms must be replaced if they are defective or dirty and previous cleaning has not successfully remedied the problem.

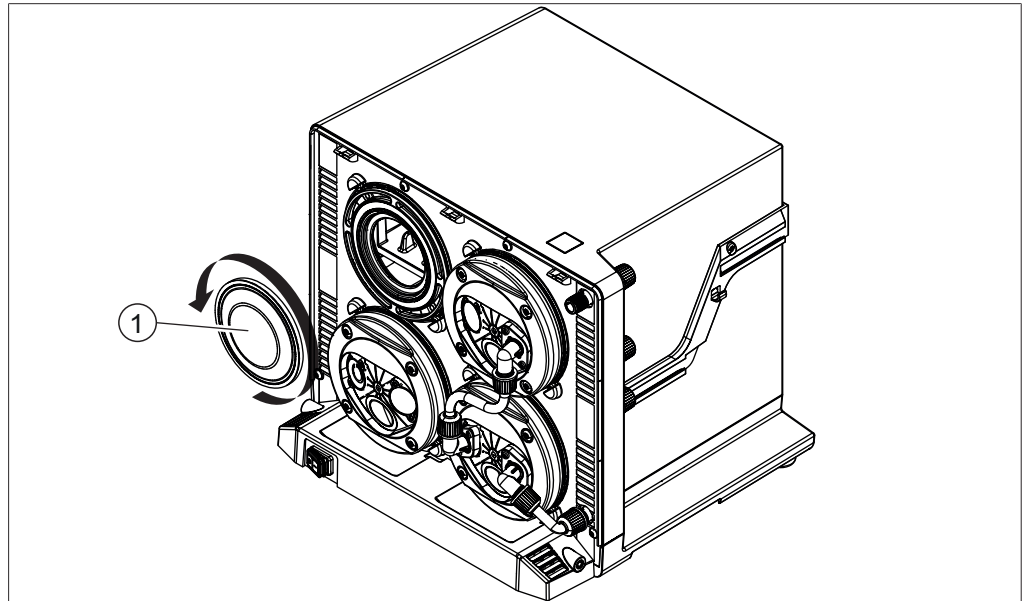

Fig. 27: Pump heads and diaphragms of V-600

#### 1 Diaphragm

Tools required:

- Diaphragm grips (see Spare parts).

Precondition:

- Pump has been shut down.

- ▶ Remove the casing front, see Chapter 7.2.2 "Dismantling and reassembling pump head", page 49.
- ▶ Remove the connecting components, see Chapter "Step 1: Removing connecting components", page 50.
- ▶ Remove the fixing ring and pump head, see Chapter "Step 2: dismantling pump head", page 51.
- ▶ Grip diaphragm (1) with diaphragm grips and turn counter-clockwise.
- ▶ Remove old diaphragm, insert new diaphragm and tighten using the diaphragm grips.
- ▶ Tighten new diaphragm by turning clockwise with the diaphragm grips. When doing so, tighten the diaphragm until the diaphragm grips slip.
- ▶ Fit the pump head and fixing ring over the diaphragm and fix in place..
- ▶ Refit connecting components.
- ▶ Refit casing front.

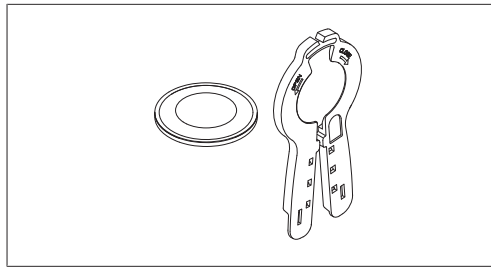

Fig. 28: Diaphragm grips for unscrewing and tightening the diaphragms in the V-600



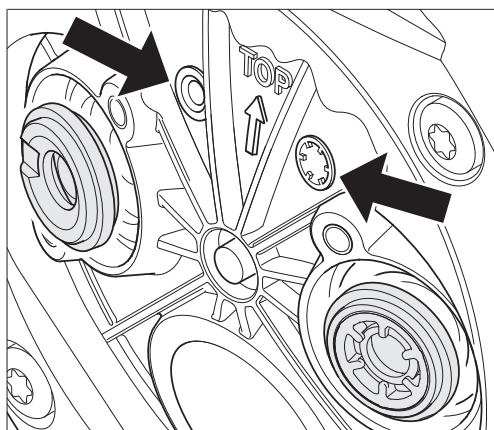

Fig. 30: Orientation of non-return valves according to symbols

- ▶ Refit the elbow connectors together with connecting components, see Chapter "Step 3: Reassembling and refitting the pump head", page 52.
- ▶ Refit front casing.



#### NOTE

The diaphragm grips supplied have a notch in the front of the right-hand grip. This can be used as an aid to removing the non-return valves from the elbow connectors.

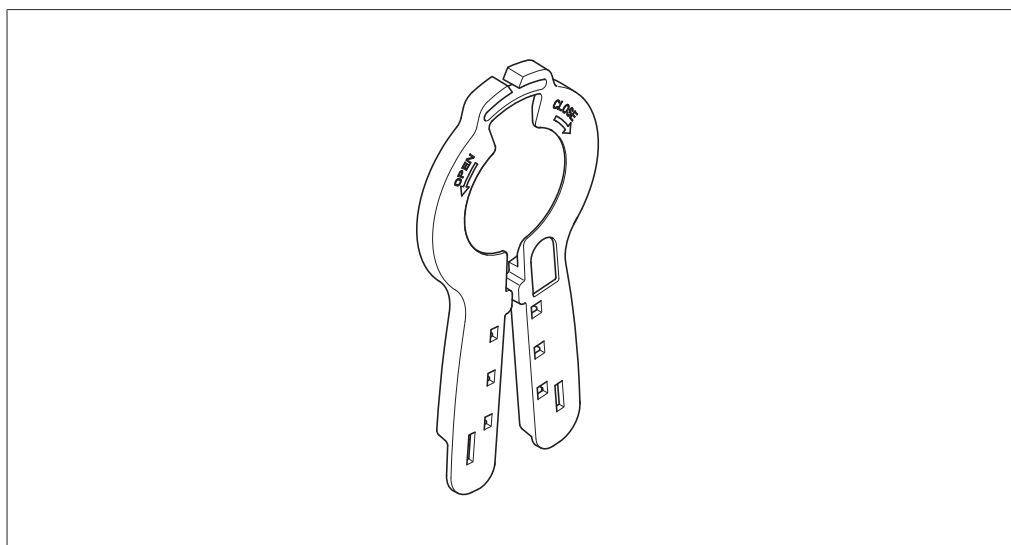

Fig. 31: Diaphragm grips with notch in right-hand grip for removing non-return valves

## 7.2.5 Replacing connecting tubes

The V-600 has a total of four connecting tubes on the pump heads, see Chapter "Step 1: Removing connecting components", page 50.

### Replacing pump-head connecting tube

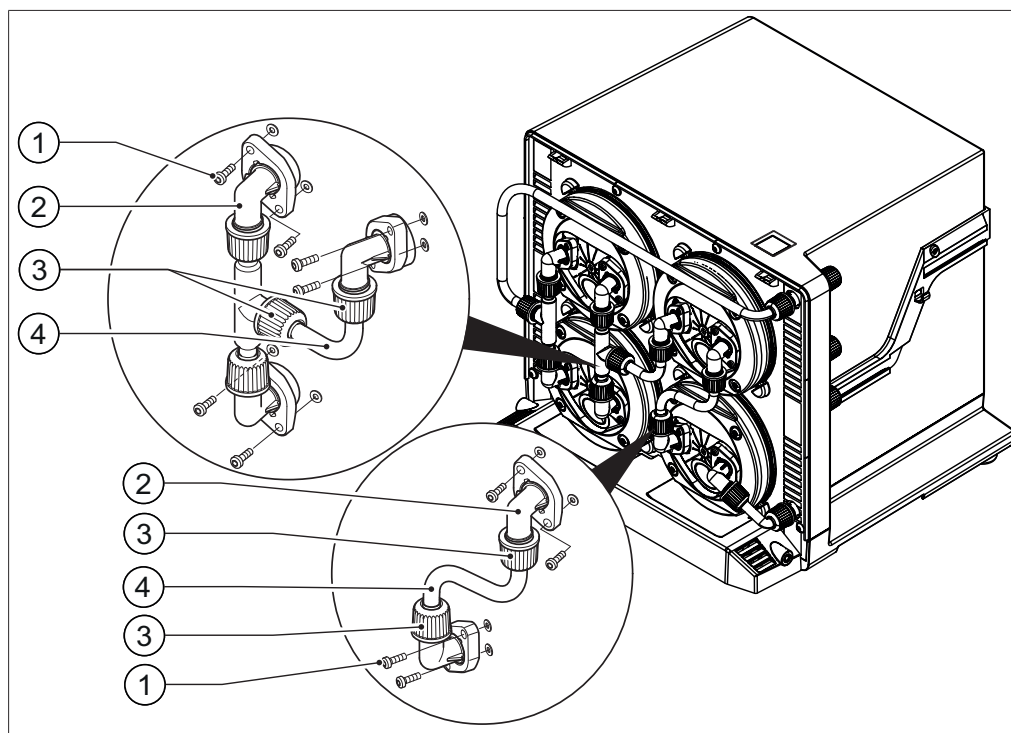

Fig. 32: Pump-head connecting tube in V-600

- |   |                                   |   |                           |
|---|-----------------------------------|---|---------------------------|
| 1 | Fixing screws for elbow connector | 3 | GL14 union nut            |
| 2 | Elbow connector                   | 4 | Pump-head connecting tube |

Tools required:

- Torx key Tx10
- ▶ Remove the casing front, see Chapter 7.2.2 "Dismantling and reassembling pump head", page 49.
- ▶ Unscrew the fixing screws (1) from the elbow connectors (2).
- ▶ Remove the elbow connectors together with the connecting component.
- ▶ Unscrew and pull back the GL14 union nut (3) on each end of the pump-head connecting tube (4).
- ▶ Pull the ends of the tubes out of the elbow connectors.
- ▶ Pull the GL14 union nuts off the connecting tube and dispose of the old connecting tube.
- ▶ Loosely fit two new union nuts with tube seals on the connectors, see Chapter 7.2.8 "Fitting GL14 cap nut with tube seal", page 62. **NOTICE! If incorrectly fitted, the tube seals may be damaged.**
- ▶ Insert new connecting tube into the elbow connectors, taking care not to damage the tube seals when doing so.
- ▶ Fit the elbow connectors together with connecting components onto the ports in the pump heads and screw in place.

- ▶ Tighten the two union nuts.
- ▶ Refit casing front.

### Replacing connecting tube to pump intake or pump outlet

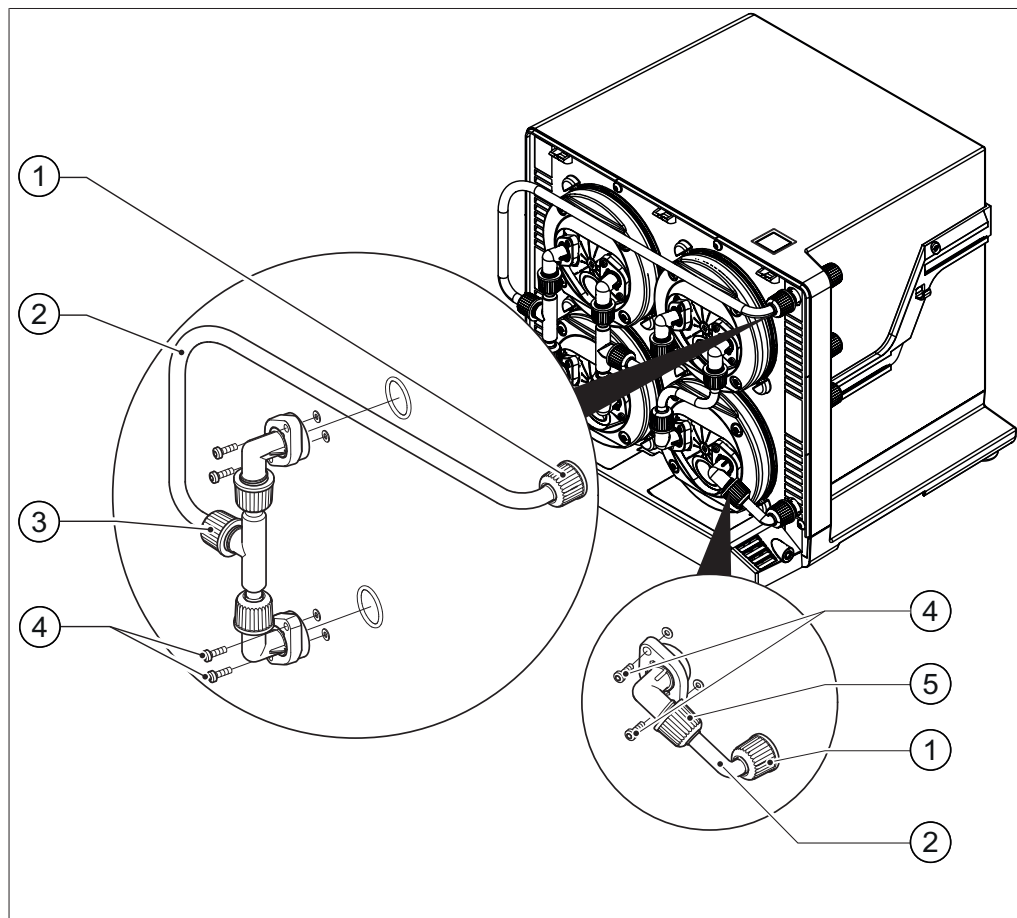

Fig. 33: Connecting tubes to the V-600 pump heads

- |   |                      |   |                                   |
|---|----------------------|---|-----------------------------------|
| 1 | GL14 union nut       | 4 | Fixing screws for elbow connector |
| 2 | Connecting tube      | 5 | Union nut on the elbow connector  |
| 3 | Union nut on T-piece |   |                                   |

#### Tools required:

- Torx key Tx10
- ▶ Remove the casing front, see Chapter 7.2.2 "Dismantling and reassembling pump head", page 49.
- ▶ Unscrew the fixing screws (4) from the elbow connectors on the pump heads.
- ▶ Unscrew and pull back the GL14 union nut (1) on the connection for the pump intake or pump outlet.
- ▶ Remove the connecting component together with elbow connectors.
- ▶ Unscrew and pull back the GL14 union nut on the elbow connector (5) or T-piece (3).
- ▶ Pull the end of the tube out of the elbow connector/T-piece.
- ▶ Pull the GL14 union nuts off the connecting tube and dispose of the old connecting tube.

- ▶ Loosely fit two new union nuts with tube seals on the connector and on the connection for the pump intake or pump outlet, see Chapter 7.2.8 "Fitting GL14 cap nut with tube seal", page 62. **NOTICE! If incorrectly fitted, the tube seals may be damaged.**
- ▶ Insert one end of the connecting tube (see illustration) into the elbow connector/ T-piece, taking care not to damage the tube seal when doing so.
- ▶ Insert the other end of the connecting tube into the pump intake or pump inlet connection, taking care not to damage the tube seal when doing so.
- ▶ Fit the elbow connectors onto the ports in the pump heads and screw in place.
- ▶ Tighten the GL14 union nuts on the connection for the pump intake/pump outlet and elbow connector.
- ▶ Refit casing front.

## 7.2.6 Replacing O-rings

The O-rings have to be replaced if the V-600 is no longer functioning to full capacity and no longer achieving the terminal vacuum. In such cases, it makes sense to replace all eight O-rings in the elbow connectors on the pump heads (see Chapter 7.2.4 "Replacing the non-return valve", page 55).

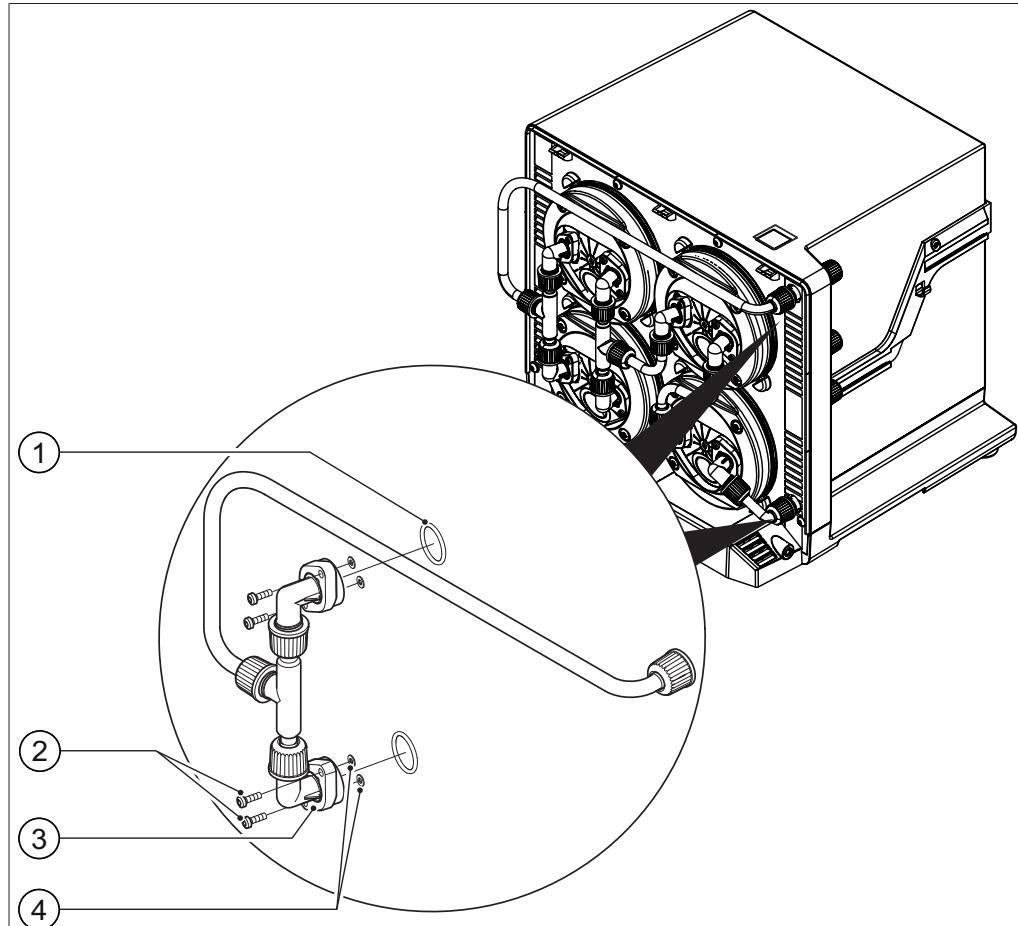

Fig. 34: Connecting components, elbow connectors and O-rings inside V-600

- |                                     |                   |
|-------------------------------------|-------------------|
| 1 O-ring                            | 3 Elbow connector |
| 2 Fixing screws for elbow connector |                   |

- ▶ Remove the casing front, see Chapter 7.2.2 "Dismantling and reassembling pump head", page 49.
- ▶ Remove the elbow connectors (3) together with connecting components, see Chapter "Step 1: Removing connecting components", page 50.
- ▶ Remove the old O-rings (1) together with the non-return valves from the elbow connectors. Use the diaphragm grips to do so., Chapter 7.2.7 "Removing non-return valve from elbow connector", page 61.
- ▶ Insert new O-rings together with non-return valves in the elbow connectors.  
**NOTICE! When inserting the valves, pay attention to the symbols on the pump heads! The two valves on each pump head are inserted the opposite way round from each other.**



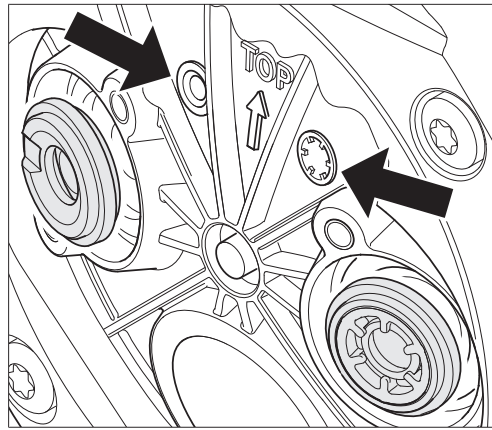

Fig. 35: Orientation of non-return valves according to symbols

- ▶ Refit the elbow connectors together with connecting components, see Chapter "Step 3: Reassembling and refitting the pump head", page 52.
- ▶ Refit casing front.

### 7.2.7 Removing non-return valve from elbow connector

The diaphragm grips supplied have a notch in the front of the right-hand grip. This can be used as an aid to removing the non-return valves from the elbow connectors.

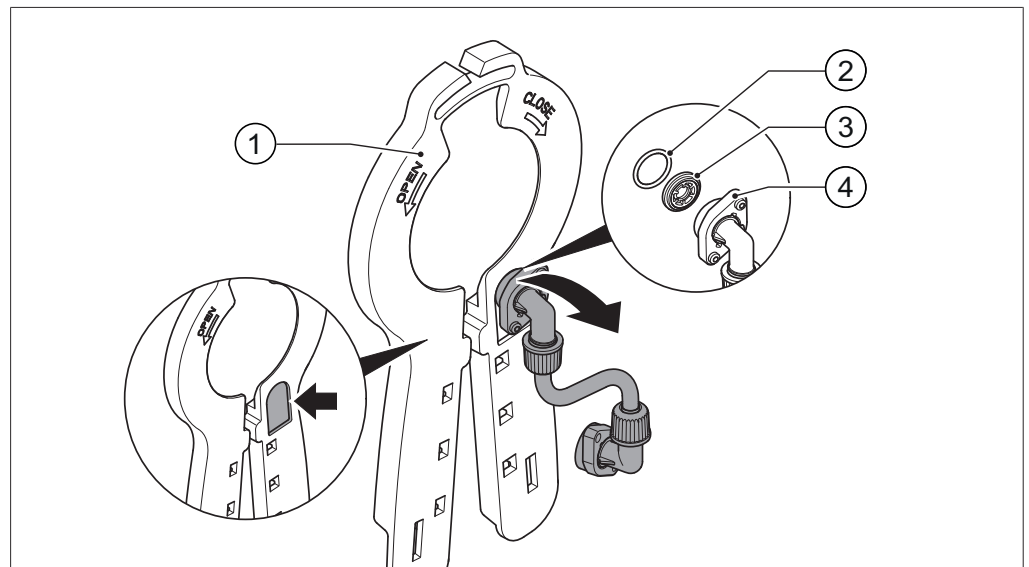

Fig. 36: Diaphragm grips with notch in right-hand grip for removing non-return valves

- |   |                 |   |                  |
|---|-----------------|---|------------------|
| 1 | Diaphragm grips | 3 | Non-return valve |
| 2 | O-ring          | 4 | Elbow connector  |

- ▶ Slide the connector (4) up to the top of the notch in the diaphragm grips.
  - ▶ Press the connector upwards slightly so that the non-return valve twists in the notch and then tilt it down.
- ⇒ The non-return valve and O-ring come away from the connector.

## 7.2.8 Fitting GL14 cap nut with tube seal

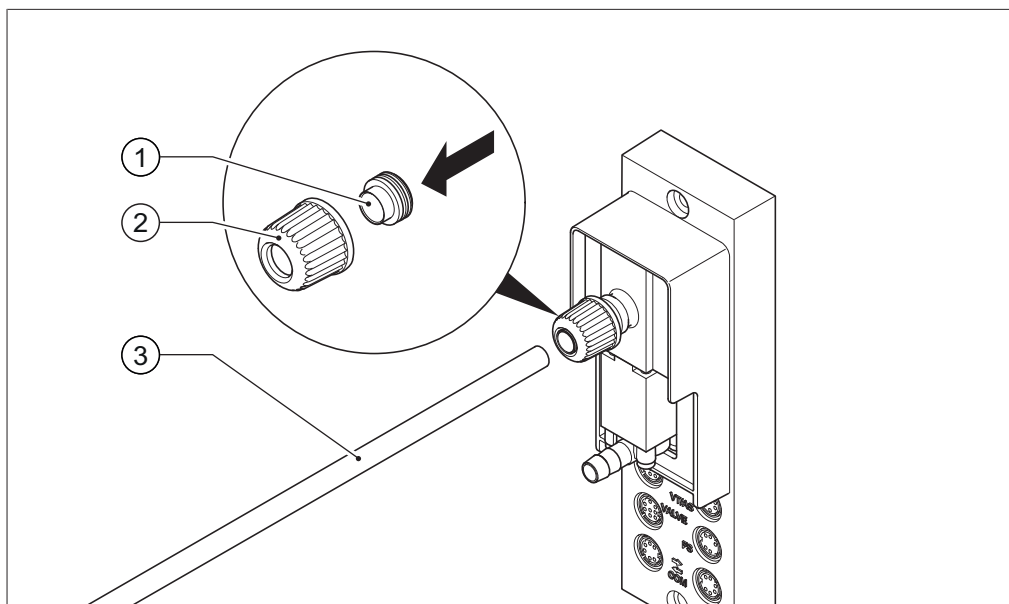

Fig. 37: Fitting GL14 cap nut with tube seal (example shows VacuBox)

- |   |              |   |        |
|---|--------------|---|--------|
| 1 | Tube seal    | 3 | Tubing |
| 2 | GL14 cap nut |   |        |

- ▶ Insert the tube seal (1) in the GL14 cap nut (2) ensuring it is straight. **NOTICE! Risk of damaging tube seal.** Make sure that the tube seal does not twist or jam in the GL14 cap nut.
- ▶ Loosely screw the GL14 cap nut together with tube seal onto the device concerned (example shows VacuBox) or the Woulff bottle.
- ▶ Carefully insert the end of the tube (3) into the GL14 cap nut and tube seal.
- ▶ Tighten the GL14 cap nut and tube seal.

## 8 Help with faults

### 8.1 Faults, possible causes and remedies

Fault	Possible cause	Remedy
Device does not work.	Master switch is off.	▶ Switch on master switch.
	Device is not connected to a power supply.	▶ Check power supply.
	The outlet of the pump or a downstream device is closed off.	▶ Make sure that all outlets are open.
System is leaking (leakage rate is greater than 5 mbar) and cannot achieve terminal vacuum. See also operating instructions of Interface I-300/I-300 Pro, section "Performing leak test".	Connections reversed.	Join up connections as described in Chapter 5.4 "Connecting laboratory equipment", page 25.
	GL14 union nuts and tube seals not correctly fitted or are damaged.	▶ Inspect GL14 union nuts and tube seals, (see Chapter 7.2.5 "Replacing connecting tubes", page 57).
	Tubing leaking (and brittle).	▶ Replace tubing (see Chapter 7.2.5 "Replacing connecting tubes", page 57).
	Diaphragm and/or valves dirty.	▶ Clean or replace diaphragm and/or valves (see Chapter 7.2.3 "Replacing the diaphragm", page 53 and Chapter 7.2.4 "Replacing the non-return valve", page 55).
	Valve O-rings are leaking.	▶ Replace O-rings (see Chapter 7.2.6 "Replacing O-rings", page 60).
Pump fails to start.	Casing front not properly closed.	▶ Check seating of casing front and correct if necessary. The cover is fixed by two knurled-head screws.
Pump starts then stops again shortly afterwards (in standalone operation).	Fan is defective.	▶ Contact BUCHI Customer Service.

## 8.2 Customer service

Repairs to the device may only be carried out by authorized service technicians. The service technicians have been comprehensively technically trained and are aware of the potential hazards that can arise from the device.

The addresses of the official BUCHI Customer Service offices can be found on the BUCHI website at: [www.buchi.com](http://www.buchi.com). If you have any questions regarding technical issues or faults, please contact those offices.

Customer Services can offer you:

- supply of spare parts
- repairs
- technical advice

## 9 Taking out of service and disposal

### 9.1 Taking out of service

- ▶ Remove all tubing and communication cables from the device.
- ▶ Run the pump to dry out tubing and diaphragms inside the pump.
- ▶ Switch off the pump and disconnect it from the mains power supply.

### 9.2 Disposal

The operator is responsible for proper disposal of the *[Vacuum Pump]*.

- ▶ When disposing of equipment observe the local regulations and statutory requirements regarding waste disposal.

## 10 Appendix

### 10.1 Solvent table

Solvent	Formula	Molar mass in g/mol	Evaporation energy in J/g	Boiling point in °C at 1013 mbar	Density in g/cm <sup>3</sup>	Vacuum in mbar for 40 °C boiling point
Acetone	CH <sub>3</sub> H <sub>6</sub> O	58.1	553	56	0.790	556
<i>n</i> -pentanol	C <sub>5</sub> H <sub>12</sub> O	88.1	595	137	0.814	11
Benzene	C <sub>6</sub> H <sub>6</sub>	78.1	548	80	0.877	236
<i>n</i> -butanol	C <sub>4</sub> H <sub>10</sub> O	74.1	620	118	0.810	25
<i>tert</i> -butanol	C <sub>4</sub> H <sub>10</sub> O	74.1	590	82	0.789	130
Chlorobenzene	C <sub>6</sub> H <sub>5</sub> Cl	112.6	377	132	1.106	36
Chloroform	CHCl <sub>3</sub>	119.4	264	62	1.483	474
Cyclohexane	C <sub>6</sub> H <sub>12</sub>	84.0	389	81	0.779	235
Diethyl ether	C <sub>4</sub> H <sub>10</sub> O	74.0	389	35	0.714	850
1,2-dichloroethane	C <sub>2</sub> H <sub>4</sub> Cl <sub>2</sub>	99.0	335	84	1.235	210
<i>cis</i> -1,2- dichloroethene	C <sub>2</sub> H <sub>2</sub> Cl <sub>2</sub>	97.0	322	60	1.284	479
<i>trans</i> -1,2- dichloroethene	C <sub>2</sub> H <sub>2</sub> Cl <sub>2</sub>	97.0	314	48	1.257	751
Di-isopropyl ether	C <sub>6</sub> H <sub>14</sub> O	102.0	318	68	0.724	375
Dioxane	C <sub>4</sub> H <sub>8</sub> O <sub>2</sub>	88.1	406	101	1.034	107
DMF (dimethylfor- mamide)	C <sub>3</sub> H <sub>7</sub> NO	73.1	–	153	0.949	11
Acetic acid	C <sub>2</sub> H <sub>4</sub> O <sub>2</sub>	60.0	695	118	1.049	44
Ethanol	C <sub>2</sub> H <sub>6</sub> O	46.0	879	79	0.789	175
Ethylacetate	C <sub>4</sub> H <sub>8</sub> O <sub>2</sub>	88.1	394	77	0.900	240
Heptane	C <sub>7</sub> H <sub>16</sub>	100.2	373	98	0.684	120
Hexane	C <sub>6</sub> H <sub>14</sub>	86.2	368	69	0.660	360
Isopropanol	C <sub>3</sub> H <sub>8</sub> O	60.1	699	82	0.786	137
Isopentanol	C <sub>5</sub> H <sub>12</sub> O	88.1	595	129	0.809	14
Methylethylketone	C <sub>4</sub> H <sub>8</sub> O	72.1	473	80	0.805	243
Methanol	CH <sub>4</sub> O	32.0	1227	65	0.791	337
Dichlormethane	CH <sub>2</sub> Cl <sub>2</sub>	84.9	373	40	1.327	850
Pentane	C <sub>5</sub> H <sub>12</sub>	72.1	381	36	0.626	850
<i>n</i> -propanol	C <sub>3</sub> H <sub>8</sub> O	60.1	787	97	0.804	67
Pentachloroethane	C <sub>2</sub> HCl <sub>5</sub>	202.3	201	162	1.680	13
1,1,2,2-tetra- chloroethane	C <sub>2</sub> H <sub>2</sub> Cl <sub>4</sub>	167.9	247	146	1.595	20
Tetrachloromethane	CCl <sub>4</sub>	153.8	226	77	1.594	271

<b>Solvent</b>	<b>Formula</b>	<b>Molar mass in g/mol</b>	<b>Evaporation energy in J/g</b>	<b>Boiling point in °C at 1013 mbar</b>	<b>Density in g/cm<sup>3</sup></b>	<b>Vacuum in mbar for 40 °C boiling point</b>
1,1,1-trichloroethane	C <sub>2</sub> H <sub>3</sub> Cl <sub>3</sub>	133.4	251	74	1.339	300
Tetrachloroethene	C <sub>2</sub> Cl <sub>4</sub>	165.8	234	121	1.623	53
THF (tetrahydrofu- ran)	C <sub>4</sub> H <sub>8</sub> O	72.1	–	67	0.889	374
Toluene	C <sub>7</sub> H <sub>8</sub>	92.2	427	111	0.867	77
Trichloroethene	C <sub>2</sub> HCl <sub>3</sub>	131.3	264	87	1.464	183
Water	H <sub>2</sub> O	18.0	2261	100	1.000	72
Xylene (mixture)	C <sub>8</sub> H <sub>10</sub>	106.2	389	–	–	25
<i>o</i> -xylene	C <sub>8</sub> H <sub>10</sub>	106.2	–	144	0.880	–
<i>m</i> -xylene	C <sub>8</sub> H <sub>10</sub>	106.2	–	139	0.864	–
<i>p</i> -xylene	C <sub>8</sub> H <sub>10</sub>	106.2	–	138	0.861	–

## 10.2 Spare parts and accessories

Use only genuine BUCHI consumables and spare parts in order to ensure correct, safe and reliable operation of the system.



### NOTE

Any modifications of spare parts or assemblies are only allowed with the prior written permission of BUCHI.

### 10.2.1 Accessories



#### Receiving flask

	Order no.
Glass, SJ35/20, 250 mL	000423
Glass, SJ35/20, 250 mL, P+G	11060907
Glass, SJ35/20, 500 mL	000424
Glass, SJ35/20, 500 mL, P+G	025264

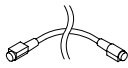
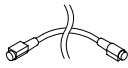
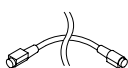
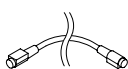
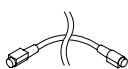
#### Communication cables

	Order no.	Image
Communication cable. BUCHI COM, 0.3 m, 6p Enables connection between Rotavapor® R-300 / R-220 Pro, Interface I-300 / I-300 Pro, Vacuum Pump V-300 / V-600, Recirculating Chiller F-3xx, VacuBox and LegacyBox.	11058705	
Communication cable. BUCHI COM, 0.9 m, 6p Enables connection between Rotavapor® R-300 / R-220 Pro, Interface I-300 / I-300 Pro, Vacuum Pump V-300 / V-600, Recirculating Chiller F-3xx, VacuBox and LegacyBox.  Enables connection between Pure® C-900, C-106 Fraction Collector, C-107 UV Detector.	11070540	
Communication cable. BUCHI COM, 1.8 m, 6p Enables connection between Rotavapor® R-300 / R-220 Pro, Interface I-300 / I-300 Pro, Vacuum Pump V-300 / V-600, Recirculating Chiller F-3xx, VacuBox and LegacyBox.	11058707	
Communication cable. BUCHI COM, 5.0 m, 6p Enables connection between Rotavapor® R-300 / R-220 Pro, Interface I-300 / I-300 Pro, Vacuum Pump V-300 / V-600, Recirculating Chiller F-3xx, VacuBox and LegacyBox.	11058708	
Communication cable. BUCHI COM, 15 m, 6p Enables connection between Rotavapor®, Interface, Vacuum Pump, Recirculating Chiller, VacuBox and LegacyBox.	11064090	

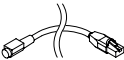
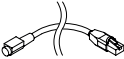

	Order no.	Image
<p>Communication cable. Mini-DIN 6p to RJ45, 1.5 m</p> <p>Connection between Vacuum Controller V-850 / V-855 and Vacuum Pump V-300 / V-600 or between Vacuum Controller V-850 / V-855, Interface I-100 and Recirculating Chiller F-305 / F-308 / F-314.</p>	11060649	
<p>Communication cable. Mini-DIN 6p to RJ45, 3 m</p> <p>Connection between Vacuum Controller V-850 / V-855 and Vacuum Pump V-300 / V-600 or between Vacuum Controller V-850 / V-855, Interface I-100 and Recirculating Chiller F-305 / F-308 / F-314.</p>	11064104	
<p>Communication cable. Mini-DIN, Y-piece, 2.0 m</p> <p>Meant to be used with 1 Vacuum Pump V-300 and 2 Rotavapor® systems with the Interface I-300/I-300 Pro. Connection between VacuBox and Vacuum Pump V-300.</p>	11062255	

### Secondary condensers

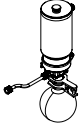
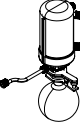
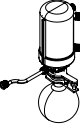



	Order no.	Image
<p>Secondary condenser C, set. Cold trap P+G-LT, incl. V-300 holder</p> <p>Condenses remaining vapors after the vacuum pump outlet. Application temperature: -70 to 40 °C. Used with ice/dry ice. Content: Cold trap P+G-LT, 500 mL receiving flask, ball joint clamp, V-300 holder. Compatible with V-300 and V-600 vacuum pumps.</p>	11060050	
<p>Secondary condenser V, set. Glass condenser, incl. insulator and V-300 holder</p> <p>Condenses remaining vapors after the vacuum pump outlet. Used along with a recirculating chiller or tap water. Content: glass condenser, receiving flask 500 mL, insulator for condenser, ball joint clamp, V-300 holder. Compatible with V-300 and V-600 vacuum pumps.</p>	11059900	
<p>Secondary condenser V, set. Used with F-325</p> <p>Condenses remaining vapors after the vacuum pump outlet. Used along with a Recirculating Chiller F-325, Vacuum Pump V-600 (11V600810) and Rotavapor R-220 Pro. Content: glass condenser, receiving flask 500 mL, insulator for condenser, ball joint clamp, holder.</p>	11064699	

### Tubing

	Order no.
<p>Tubing. FEP, Ø6/8 mm, transparent, per m</p> <p>Use: Vacuum, cooling media.</p>	027900
<p>Tubing. Natural rubber, Ø6/16 mm, red, per m</p> <p>Use: Vacuum.</p>	017622
<p>Tubing. Nylflex, PVC-P, Ø8/14 mm, transparent, per m</p>	004113

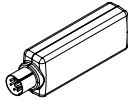
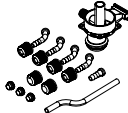
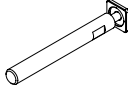
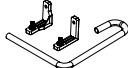
	<b>Order no.</b>
Tubing. Silicone, Ø6/9 mm, transparent, per m Use: Cooling media.	004133
Tubing. Synthetic rubber, Ø6/13 mm, black, per m Use: Vacuum.	11063244

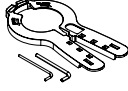
### Further accessories

	<b>Order no.</b>	<b>Image</b>
BUCHI Bluetooth® Dongle, connects instrument to smartphone via Bluetooth®	11067770	
Holder set. For V-7xx secondary condenser on V-300 / V-600 Used to mount V-7xx secondary condenser on the Vacuum Pump V-300 or V-600.	11065095	
Holder, set. To fix V-8xx, I-100 or Manometer on V-300 / V-600 Used to mount Vacuum Controller V-8xx, Manometer or Interface I-100 on the Vacuum Pump V-300 / V-600. Content: rod and intermediate plate.	11065224	
Fastening set. For VacuBox, incl. holder 2 pcs, tube Used to fasten VacuBox on the Vacuum Pump V-300 or V-600.	11062957	
Level sensor. Incl. O-ring, cable, rubber band Prevents an overflow in the receiving flask of condenser/ secondary condenser. Placed on receiving flask. Meant to be used with the Interface I-300 / I-300 Pro.	11060954	
Membrane clamp. Incl. torx wrench TX25, TX10 To fasten and remove membranes.	11062343	
Valve unit. Incl. Woulff bottle, 125 mL, P+G, holder Magnetic valve, meant to be used with the Interface I-300/ I-300 Pro. For operation with non-BUCHI vacuum pumps or house vacuum.	11061887	
Woulff bottle. 125 mL, P+G, incl. holder For trapping particles and droplets and for pressure equalization.	11059905	

## 10.2.2 Wearing parts

### Seals

	Order no.
Gasket. Flat gasket, silicone, PTFE	047165
Seal	038225
For cap nut GL14, EPDM seal	
Seals, set. 10 pcs, for hose barbs GL14, EPDM, black	040029
Seals, set. 10 pcs, for hose barbs GL14, FPM, green	040040
Seals, set. 10 pcs, for hose barbs GL14, silicone, red	040023

### Hose barbs

	Order no.	Image
Hose barbs. set. 3 pcs, bent, GL14, silicone seal Content: Hose barbs, seals.	041987	
Hose barbs, set. 4 pcs, bent GL14, silicone seal Content: Hose barbs, cap nuts, seals	037287	
Hose barbs. set. 4 pcs, bent, GL14, EPDM seal Content: Hose barbs, cap nuts, seals.	043129	
Hose barbs, set 4 pcs, bent, GL14, FPM seal Content: Hose barbs, cap nuts, seals.	040295	
Hose barbs. set. 4 pcs, straight, GL14, EPDM seal Content: Hose barbs, cap nuts, seals.	043128	
Hose barbs. set. 4 pcs, straight, GL14, FPM seal Content: Hose barbs, cap nuts, seals.	040296	
Hose barbs, set. 4 pcs, straight, GL14, silicone seal Content: Hose barbs, cap nuts, seals	037642	
Hose barbs. set. 6 pcs, bent (4), straight (2), GL14, silicone seal Content: Hose barbs, cap nuts, seals.	038000	



### Miscellaneous wearing parts

	Order no.	Image
<p>Cap nuts, set. 10 pcs, screw cap with hole GL14, seal EPDM</p> <p>Content: Cap nuts, seals</p>	041999	
<p>Cap nuts, set. 10 pcs, screw cap with hole, GL14</p>	041956	
<p>Membrane, set. 2x, for V-300 / V-600, V-100, V-7xx</p> <p>Content: 2 membranes with support rings and 1 membrane clamp.</p>	11065776	
<p>O-ring. For secondary condenser, FKM/FEP, Ø28.2/2.6 mm</p>	11057661	
<p>Screw caps, set. 5 pcs, GL14</p>	040624	
<p>Set gas ballast. Incl. gas ballast, clip, lever</p>	11062527	
<p>Screwing set, Hose barbs and seals GL14</p> <p>Content: Hose barbs bent 4 pcs, hose barbs straight 1 pc, cap nuts 4 pcs, screw caps 2 pcs, seals EPDM 3 pcs.</p>	11061921	
<p>Set wear part for V-600, incl. membranes, hoses and hose barbs</p> <p>Content: Membrane 4 pcs, support ring 4 pcs, check valves 4 pcs, FEP tubes, T-connector and hose barbs. Only for Vacuum Pump V-600.</p>	11065180	



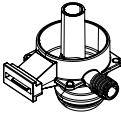
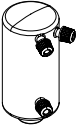

### 10.2.3 Spare parts

#### Secondary condensers

	Order no.	Image
<p>Secondary condenser C. Cold trap, P+G-LT</p> <p>Condenses remaining vapors after the vacuum pump outlet. Application temperature: -70 to 40 °C. Used with ice/dry ice. Content: Secondary cold trap condenser and cap nut GL14 (1 pcs). Compatible with V-100, V-7xx, V-300 and V-600 vacuum pumps.</p>	047191	

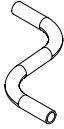

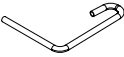

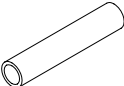

	Order no.	Image
<p>Support secondary condenser</p> <p>Compatible with V-300 / V-600</p>	11059901	
<p>Secondary condenser V. Glass condenser</p> <p>Condenses remaining vapors after the vacuum pump outlet. Used along with a recirculating chiller or tap water. Content: Secondary V condenser, cap nut GL14 (3 pcs). Compatible with V-100, V-7xx, V-300 and V-600 vacuum pumps. Does not include holder and insulator.</p>	11059902	
<p>Secondary condenser V. Glass condenser, incl. Insulator, excl. Holder</p> <p>Condenses remaining vapors after the vacuum pump outlet. Used along with a recirculating chiller or tap water. Content: Secondary V condenser, cap nut GL14 (3 pcs) and condenser insulation. Compatible with V-100, V-7xx, V-300 and V-600 vacuum pumps. Does not include the holder.</p>	11063841	

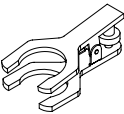
### Tubing

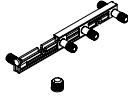
	Order no.	Image
<p>Tube. Connection part for Vacuum pump V-300 / V-600, FEP</p> <p>Used to connect two membrane heads together.</p>	11059623	
<p>Tube. Vacuum intake for Vacuum pump V-300 / V-600, FEP</p> <p>Used for connection between the first membrane head and the vacuum intake.</p>	11059624	
<p>Tubing FEP, Ø6/8 mm, transparent</p> <p>Connection tubing VacuBox.</p>	11059919	
<p>Tubing. FEP, Ø6/8 mm, transparent</p> <p>Connection tubing secondary condenser.</p>	11059904	
<p>Tubing. FEP, Ø6/8 mm, transparent, 40 mm</p> <p>Connection tubing Woulff bottle.</p>	11059909	

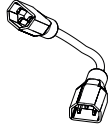
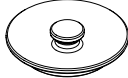
### Further spare parts

	Order no.	Image
<p>Ball joint clamp. For BJ35/20</p> <p>To fasten receiving flask on condenser/secondary condenser.</p>	003275	

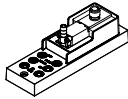
	Order no.	Image
Check valves, set. 4 pcs, incl. O-ring	11060610	
Distributor, set. V-300 / V-600 distributor and 1 screw cap GL14 Used to replace the gas ballast lever with a screw cap GL14.	11065620	
Holder. For valve unit/Woulff bottle To fasten valve unit or Woulff bottle.	11059908	
Insulator. For secondary condenser (11059900) Insulation cover of the secondary condenser prevents condensation.	11059903	
Jumper cord. 1 m, black Used for electricity supply between two units. For exampl: vacuum pump and industrial Rotavapor®.	030983	
Lid. For cold trap, Ø 68 mm	047193	
Receiving vessel. For Woulff bottle, GL40, 125 mL, P+G	047233	
Seals, set 6 pcs, for cap nut GL14, EPDM seal	11060611	
Silencer. Attached at the back of the pump. Use: Absorb the sound from the vacuum pump. Compatible with Vacuum Pumps V-700, V-710, V-100, V-300 and V-600.	11062291	
Wrench Torx, TX 25 Used at installation	040469	
VacuBox. Incl. support set Communication interface between Rotavapor® R-300 and Interface I-300/I-300 Pro or Vacuum Pump V-300/V-600 and Interface I-300/ I-300 Pro.	11060914	

### 10.3 Document: 11594022 ATEX

Instrument rating to ATEX II 3G T3 IIC X

BUCHI V-300 and V-600 vacuum pumps with the rating (see ATEX supplementary plate)



II 3G T3 IIC X

Internal atm. only

Doc.: 11594022 ATEX

The vacuum pump has an ATEX II 3G T3 IIC X rating according to the European Union ATEX Directive 214/34/EU. The rating applies exclusively to the area of the unit in contact with the fluid inside the vacuum pump. The pump is not suitable for operation in an environment with a potentially explosive atmosphere.

Equipment in this category is intended for evacuation of areas in which it is unlikely that an explosive atmosphere created by gases, vapors, mist or swirling dust will occur. But if such an atmosphere does nevertheless occur, then in all probability it will happen only rarely and for a short period of time. The V-300 and V-600 are suitable for processing fluids in explosive class IIC and fluids with a flashpoint > 200°C.

The V-300 and V-600 vacuum pumps are subject to special requirements for compliance with the specified classification:

- Drawing in fluids with an intake pressure higher than atmospheric pressure is prohibited.
- Operation at ambient temperatures > 40°C is prohibited
- Drawing in fluids with a temperature > 40°C is prohibited
- The creation of sparks by foreign particles in the vacuum system must be prevented (as described in the Operating Instructions, Section 7 "Cleaning and maintenance")
- The creation of a flammable atmosphere by an unsealed vacuum system must be prevented (as described in the Operating Instructions, Section 7 "Cleaning and maintenance").

To prevent explosive mixtures forming inside the instrument, the use of gas ballast and/or venting valves is prohibited. The specified terminal vacuum (as per Operating Instructions, Section 3.5 "Technical data") of the pump must be achieved so that possible leaks can be excluded in order to prevent explosive mixtures forming inside the pump. Thus if performing work on the vacuum pump or sensor, the leakage rate must be checked.

**NOTICE!** The operating instructions must be fully read and understood before commissioning the V-300 or V-600 vacuum pump. The required measures must be taken.

## 10.4 Health and safety approval

To guarantee the health and safety of our staff and to comply with the law and the regulations for handling hazardous materials, for the purposes of health and safety at work and safe disposal of waste, no products may be sent back to BÜCHI Labortechnik AG or repaired unless we have received the declaration below, completed and signed.

Products sent to us will not be accepted for repair until we have received this declaration.

- ▶ Copy the form overleaf and complete it.
- ▶ Make sure that you know the full details of the substances with which the device has been in contact and that all questions have been answered fully and correctly.
- ▶ Send the completed form to us in advance by post or fax. The declaration must reach us before the device.
- ▶ Enclose a copy of the declaration with the device.
- ▶ If the product is contaminated, inform the carrier (in accordance with GGVE/ GGVS/RID/ADR).

If the declaration is missing or the procedure described is not followed, the repairs will be delayed. We ask for your understanding and cooperation with regard to these measures.



## 10.5 Health and safety

### Declaration regarding the safety, hazards and safe disposal of waste

To guarantee the health and safety of our staff and to comply with the law and the regulations for handling hazardous materials, regarding health and safety at work, and to comply with safety regulations, health and safety requirements and requirements for safe disposal of waste such as chemical waste, chemical residues or solvents, the form below must be fully completed and signed whenever devices or faulty components are to be sent back to our factory.

**Products or components will not be accepted if this declaration has not been provided.**

**Device** Model: \_\_\_\_\_ Part/Device no.: \_\_\_\_\_

#### Declaration for non-hazardous materials

We hereby assure that the products returned

- have not been used in the laboratory and are new.
- have not been in contact with toxic, corrosive, biologically active, explosive, radioactive or other hazardous materials.
- are not contaminated. The solvents or residues of the substances pumped have been removed.

#### Declaration for hazardous materials

In respect of the products returned, we hereby assure that

- all substances (toxic, corrosive, biologically active, explosive, radioactive or otherwise hazardous) that have been pumped by the products or have otherwise been in contact with the products are listed below.
- the products have been cleaned, decontaminated, sterilised inside and outside and all inlets and outlets are sealed.

List of hazardous materials that have been in contact with the products:

Chemical, material	Hazard category

#### Final declaration

We hereby declare that

- we are fully conversant with the substances that have been in contact with the products and have answered all questions correctly.
- we have taken all measures necessary to prevent potential hazards in respect of the products returned.

Company name or stamp:

Place, date:

Name (block letters), position  
(block letters):

Signature:

---



---

We are represented by more than 100 distribution partners worldwide.  
Find your local representative at:

[www.buchi.com](http://www.buchi.com)

Quality in your hands

---