



1260 Infinity II Degasser  
Agilent InfinityLab LC Series  
**User Manual**



# Notices

## Document Information

Document No: SD-29000216  
Part No: G7122-90000 Rev. C  
EDITION 03/2020

## Copyright

© Agilent Technologies, Inc. 2016-2020

No part of this manual may be reproduced in any form or by any means (including electronic storage and retrieval or translation into a foreign language) without prior agreement and written consent from Agilent Technologies, Inc. as governed by United States and international copyright laws.

Agilent Technologies  
Hewlett-Packard-Strasse 8  
76337 Waldbronn

## Warranty

The material contained in this document is provided "as is," and is subject to being changed, without notice, in future editions. Further, to the maximum extent permitted by applicable law, Agilent disclaims all warranties, either express or implied, with regard to this manual and any information contained herein, including but not limited to the implied warranties of merchantability and fitness for a particular purpose. Agilent shall not be liable for errors or for incidental or consequential damages in connection with the furnishing, use, or performance of this document or of any information contained herein. Should Agilent and the user have a separate written agreement with warranty terms covering the material in this document that conflict with these terms, the warranty terms in the separate agreement shall control.

## Technology Licenses

The hardware and/or software described in this document are furnished under a license and may be used or copied only in accordance with the terms of such license.

## Restricted Rights Legend

U.S. Government Restricted Rights. Software and technical data rights granted to the federal government include only those rights customarily provided to end user customers. Agilent provides this customary commercial license in Software and technical data pursuant to FAR 12.211 (Technical Data) and 12.212 (Computer Software) and, for the Department of Defense, DFARS 252.227-7015 (Technical Data - Commercial Items) and DFARS 227.7202-3 (Rights in Commercial Computer Software or Computer Software Documentation).

## Safety Notices

### CAUTION

A **CAUTION** notice denotes a hazard. It calls attention to an operating procedure, practice, or the like that, if not correctly performed or adhered to, could result in damage to the product or loss of important data. Do not proceed beyond a **CAUTION** notice until the indicated conditions are fully understood and met.

### WARNING

A **WARNING** notice denotes a hazard. It calls attention to an operating procedure, practice, or the like that, if not correctly performed or adhered to, could result in personal injury or death. Do not proceed beyond a **WARNING** notice until the indicated conditions are fully understood and met.

# In This Guide...

This manual covers the Agilent InfinityLab LC Series 1260 Infinity II Degasser (G7122A).

## **1 Introduction**

This chapter gives an introduction to the module, the operations modes and the module control.

## **2 Site Requirements and Specifications**

This chapter provides information on environmental requirements, physical and performance specifications.

## **3 Using the Degasser**

This chapter provides information for optimized usage of the module.

## **4 Troubleshooting and Diagnostics**

Overview about the troubleshooting and diagnostic features.

## **5 Maintenance**

This chapter describes the maintenance of the module.

## **6 Parts for Maintenance and Repair**

This chapter provides information on parts for maintenance.

## **7 Identifying Cables**

This chapter provides information on cables used with the Agilent InfinityLab LC Series modules.

## **8 Hardware Information**

This chapter describes the detector in more detail on hardware and electronics.

## **9 Appendix**

This chapter provides additional information on safety, legal and web.

# Contents

<b>1</b>	<b>Introduction</b>	<b>6</b>
	Introduction to the Degasser	7
	Product Description	8
	Features	9
	Operating Principle	10
	Leak and Waste Handling	11
<b>2</b>	<b>Site Requirements and Specifications</b>	<b>15</b>
	Site Requirements	16
	Physical Specifications	19
	Performance Specifications	20
<b>3</b>	<b>Using the Degasser</b>	<b>21</b>
	Magnets	22
	Turn on/off	23
	Status Indicators	25
	When to Use a Degasser?	26
	Solvent Information	28
	Prevent Blocking of Solvent Filters	34
<b>4</b>	<b>Troubleshooting and Diagnostics</b>	<b>35</b>
	Module Status Indicator	36
	Hardware Symptoms	37

<b>5</b>	<b>Maintenance</b>	<b>40</b>
	Warnings and Cautions	41
	Simple Repairs - Maintenance	43
	Clean the Instrument	44
	Assemble the Main Cover	45
	Check and Change the Power Fuses	46
<b>6</b>	<b>Parts for Maintenance and Repair</b>	<b>48</b>
	Cover Parts	49
	Accessory Kit Contents	51
<b>7</b>	<b>Identifying Cables</b>	<b>52</b>
	Cable Overview	53
	Analog Cables	55
	Remote Cables	57
	CAN/LAN Cables	61
	RS-232 Cables	62
	USB Cables	63
<b>8</b>	<b>Hardware Information</b>	<b>64</b>
	Electrical Connections	65
	Interfaces	67
	Instrument Layout	69
<b>9</b>	<b>Appendix</b>	<b>70</b>
	General Safety Information	71
	Waste Electrical and Electronic Equipment (WEEE) Directive	77
	Radio Interference	78
	Sound Emission	79
	Agilent Technologies on Internet	80



# 1

## Introduction

Introduction to the Degasser 7

Product Description 8

Features 9

Operating Principle 10

Leak and Waste Handling 11

Waste Concept 14

This chapter gives an introduction to the module, the operations modes and the module control.

## Introduction to the Degasser

The Agilent 1260 Infinity II Degasser G7122A comprises a 4-channel vacuum container, including 4 tubular plastic membranes, and a vacuum pump. When the degasser is switched on, the control circuit turns on the vacuum pump which generates a partial vacuum in the vacuum container. The pressure is measured by a pressure sensor. The vacuum degasser maintains the low pressure by a controlled leak in the air inlet filter and a regulation of the vacuum pump using the pressure sensor.

The LC pump draws the solvents from their bottles through the special tubular plastic membranes of the vacuum container. As the solvents pass through the vacuum tubes any dissolved gas in the solvents permeates through the membranes into the vacuum container. The solvents will be almost completely degassed when leaving the outlets of the degasser.

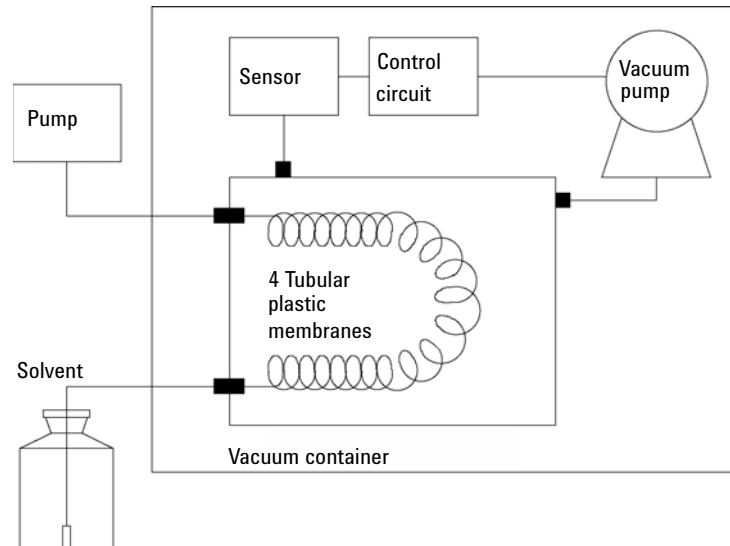
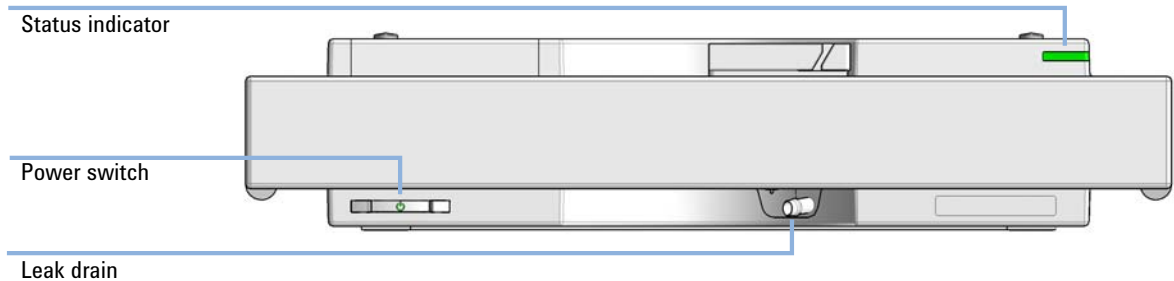

Figure 1 Overview (only one of the four solvent channels is shown)

## Product Description

The 1260 Infinity II Degasser is a standalone module for systems without internal Degasser or for usage with special applications. It reduces baseline noise and quenching effects. In fluorescence detection, lower detection limits and long-term baseline stability are achieved with the degasser. Degassing is strongly recommended for GPC/SEC applications using refractive index detection.



**Figure 2** Overview of the Degasser



## Features

- Robust design for high instrument uptime. The degassing principle is based on passing solvents through a membrane tube that is permeable to gas but not to liquid, and kept at a constant vacuum level.
- Reduced baseline noise and quenching effects through high degassing capacity. In fluorescence detection, this results in lower detection limits and long-term baseline stability.
- Strongly recommended for GPC/SEC applications using refractive index detection.

## Operating Principle

Once the degasser started, the status indicator is amber ("Not-ready") and the degasser vacuum pump tries to reach a target pressure below 100 mbar/hPa. If this limit cannot be reached within 16 minutes, an error is thrown and the status indicator switches to red ("Error mode"). As soon as the limit has been reached, which typically happens within about 8 minutes, the pump goes to a continuous regulation mode, where the pump tries to regulate to 100 mbar/hPa target pressure. If this pressure limit cannot be reached, it is increased stepwise to a maximum of 160 mbar and the status indicator switches to amber. If a stable pressure between 100 mbar and 160 mbar max. can be kept, the status indicator switches off ("Idle"). If the maximum limit of 160 mbar is exceeded, the status indicator switches to red and an error is thrown.

## Leak and Waste Handling

The Agilent InfinityLab LC Series has been designed for safe leak and waste handling. It is important that all security concepts are understood and instructions are carefully followed.

The solvent cabinet is designed to store a maximum volume of 8 L solvent. The maximum volume for an individual bottle stored in the solvent cabinet should not exceed 2 L. For details, see the usage guideline for the Agilent 1200 Infinity Series Solvent Cabinets (a printed copy of the guideline has been shipped with the solvent cabinet, electronic copies are available on the Internet).

All leak plane outlets are situated in a consistent position so that all Infinity and Infinity II modules can be stacked on top of each other. Waste tubes are guided through a channel on the right hand side of the instrument, keeping the front access clear from tubes.

The leak plane provides leak management by catching all internal liquid leaks, guiding them to the leak sensor for leak detection, and passing them on to the next module below, if the leak sensor fails. The leak sensor in the leak plane stops the running system as soon as the leak detection level is reached.

Solvent and condensate is guided through the waste channel into the waste container:

- from the detector's flow cell outlet
- from the Multisampler needle wash port
- from the Sample Cooler (condensate)
- from the Seal Wash Sensor
- from the pump's Purge Valve or Multipurpose Valve

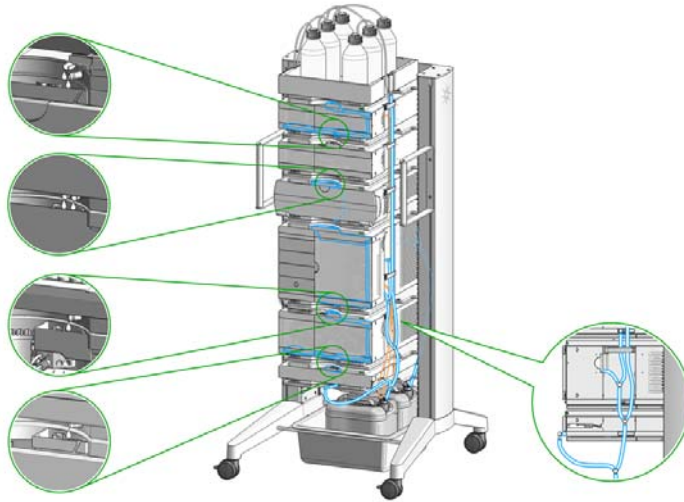

Figure 3 Infinity II Leak Waste Concept (flexible rack installation)

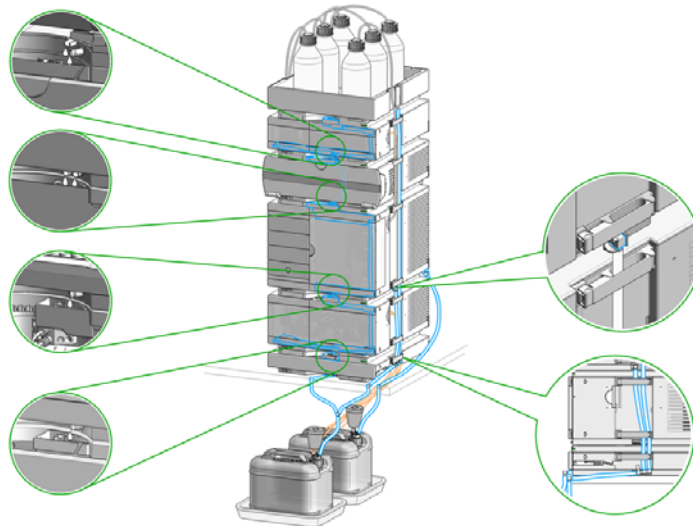
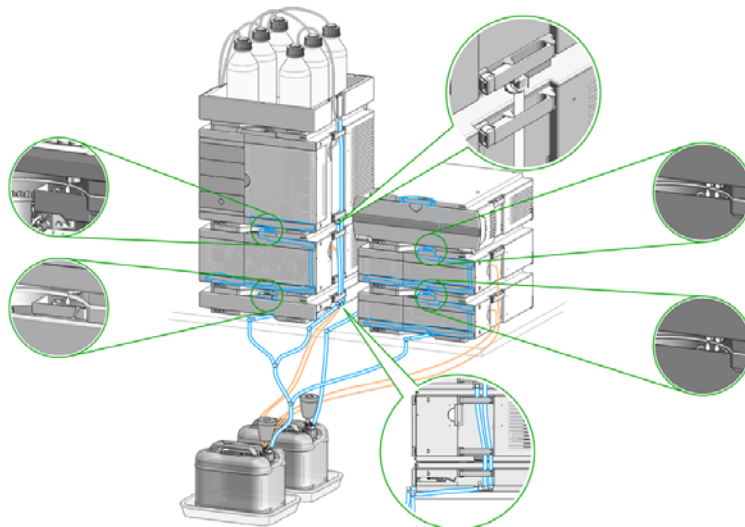

Figure 4 Infinity II Single Stack Leak Waste Concept (bench installation)



**Figure 5** Infinity II Two Stack Leak Waste Concept (bench installation)

The waste tube connected to the leak pan outlet on each of the bottom instruments guides the solvent to a suitable waste container.

## Waste Concept

- 1 Agilent recommends using the 6 L waste can with 1 Stay Safe cap GL45 with 4 ports (5043-1221) for optimal and safe waste disposal. If you decide to use your own waste solution, make sure that the tubes don't immerse in the liquid.





## 2

# Site Requirements and Specifications

Site Requirements	16
Physical Specifications	19
Performance Specifications	20

This chapter provides information on environmental requirements, physical and performance specifications.

## Site Requirements

A suitable environment is important to ensure optimal performance of the instrument.

### Power Considerations

The module power supply has wide ranging capability. It accepts any line voltage in the range described in [Table 1](#) on page 19. Consequently there is no voltage selector in the rear of the module.

**WARNING**

**Hazard of electrical shock or damage of your instrumentation can result, if the devices are connected to a line voltage higher than specified.**

- ✓ Connect your instrument to the specified line voltage only.

**WARNING**

**Electrical shock hazard**

The module is partially energized when switched off, as long as the power cord is plugged in.

The cover protects users from personal injuries, for example electrical shock.

- ✓ Do not open the cover.
- ✓ Do not operate the instrument and disconnect the power cable in case the cover has any signs of damage.
- ✓ Contact Agilent for support and request an instrument repair service.

**WARNING**

**Inaccessible power plug.**

In case of emergency it must be possible to disconnect the instrument from the power line at any time.

- ✓ Make sure the power connector of the instrument can be easily reached and unplugged.
- ✓ Provide sufficient space behind the power socket of the instrument to unplug the cable.



## Power Cords

Country-specific power cords are available for the module. The female end of all power cords is identical. It plugs into the power-input socket at the rear. The male end of each power cord is different and designed to match the wall socket of a particular country or region.

Agilent makes sure that your instrument is shipped with the power cord that is suitable for your particular country or region.

---

**WARNING****Unintended use of power cords**

**Using power cords for unintended purposes can lead to personal injury or damage of electronic equipment.**

- ✓ **Never use a power cord other than the one that Agilent shipped with this instrument.**
- ✓ **Never use the power cords that Agilent Technologies supplies with this instrument for any other equipment.**
- ✓ **Never use cables other than the ones supplied by Agilent Technologies to ensure proper functionality and compliance with safety or EMC regulations.**

---

**WARNING****Absence of ground connection**

**The absence of ground connection can lead to electric shock or short circuit.**

- ✓ **Never operate your instrumentation from a power outlet that has no ground connection.**

---

**WARNING****Electrical shock hazard**

**Solvents may damage electrical cables.**

- ✓ **Prevent electrical cables from getting in contact with solvents.**
  - ✓ **Exchange electrical cables after contact with solvents.**
-

## Bench Space

The module dimensions and weight (see [Table 1](#) on page 19) allow you to place the module on almost any desk or laboratory bench. It needs an additional 2.5 cm (1.0 inches) of space on either side and approximately 8 cm (3.1 inches) in the rear for air circulation and electric connections.

If the bench shall carry a complete HPLC system, make sure that the bench is designed to bear the weight of all modules.

The module should be operated in a horizontal position.

### NOTE

Agilent recommends that you install the HPLC instrument in the InfinityLab Flex Bench rack. This option helps to save bench space as all modules can be placed into one single stack. It also allows to easily relocate the instrument to another Lab.

## Condensation

### CAUTION

#### Condensation within the module

Condensation can damage the system electronics.

- ✓ Do not store, ship or use your module under conditions where temperature fluctuations could cause condensation within the module.
- ✓ If your module was shipped in cold weather, leave it in its box and allow it to warm slowly to room temperature to avoid condensation.

## Physical Specifications

**Table 1 Physical Specifications G1322**

Type	Specification	Comments
Weight	7.0 kg (15.4 lbs)	
Dimensions (height x width x depth)	80 x 396 x 436 mm (3.2 x 15.6 x 17.2 inches)	
Line voltage	100 – 240 V~, ± 10 %	Wide-ranging capability
Line frequency	50 or 60 Hz, ± 5 %	
Power consumption	5 W	
Ambient operating temperature	4–55 °C (39–131 °F)	
Ambient non-operating temperature	-40 – 70 °C (-40 – 158 °F)	
Humidity	< 95 % r.h. at 40 °C (104 °F)	Non-condensing
Operating altitude	Up to 3000 m (9842 ft)	
Safety standards: IEC, EN, CSA, UL	Installation category II, Pollution degree 2	For indoor use only.
ISM Classification	ISM Group 1 Class B	According to CISPR 11

## Performance Specifications

**Table 2 Performance Specifications G7122A**

Type	Specification
Maximum flow rate	10 mL/min per channel
Number of channels	4
Internal volume per channel	Typically 12 mL
Materials in contact with solvent	PTFE, PEEK
pH range	1 – 14



## 3 Using the Degasser

Magnets	22
Turn on/off	23
Status Indicators	25
When to Use a Degasser?	26
Solvent Information	28
Material Information	28
Prevent Blocking of Solvent Filters	34

This chapter provides information for optimized usage of the module.

# Magnets

1 This stack exemplarily shows the magnets' positions in the modules.

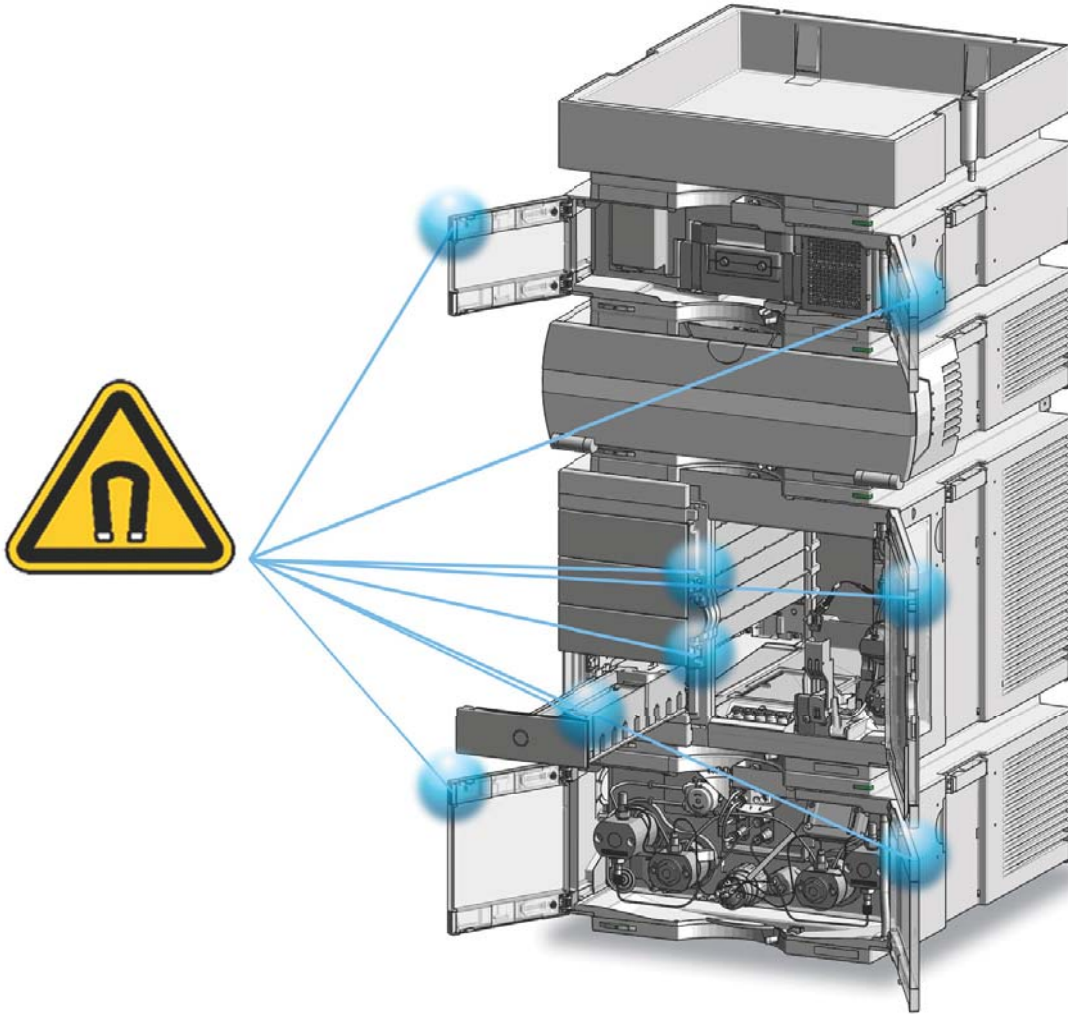

# Turn on/off

This procedure exemplarily shows an arbitrary LC stack configuration.

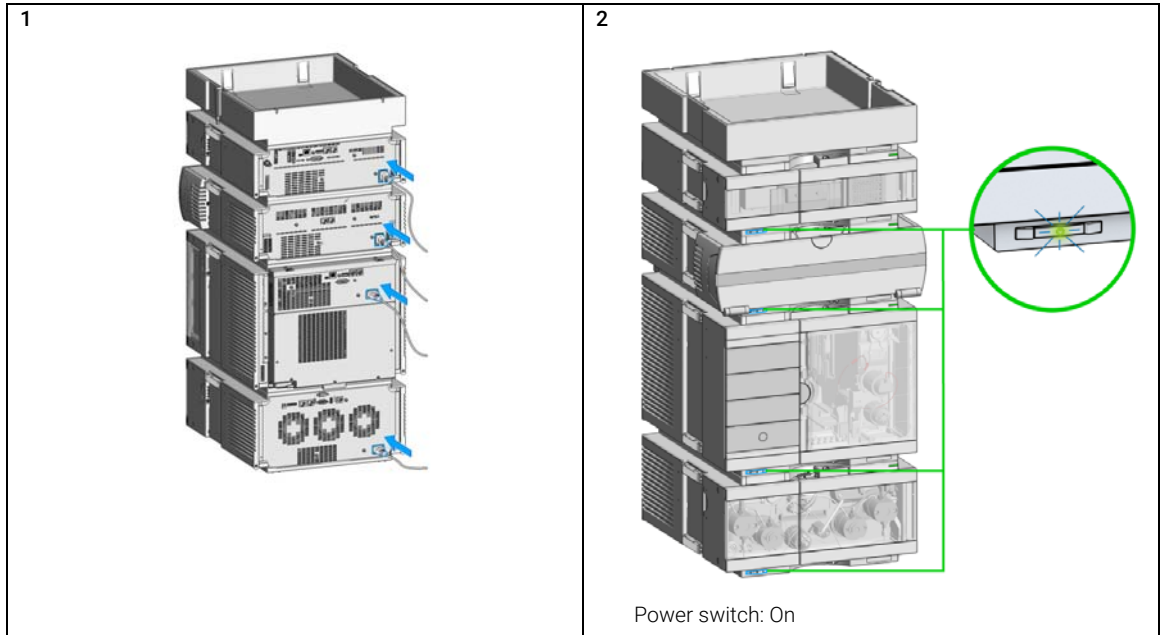

## Using the Degasser

### Turn on/off

3 Turn instrument **On/Off** with the control software.

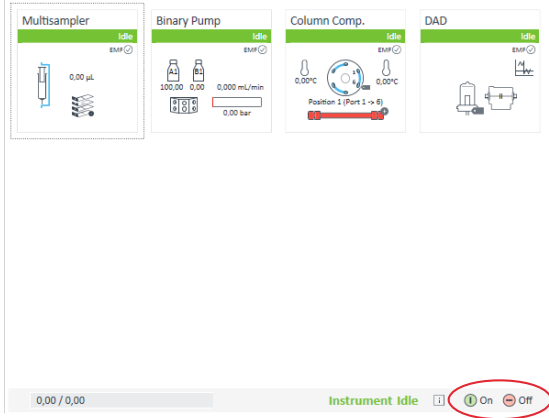

4

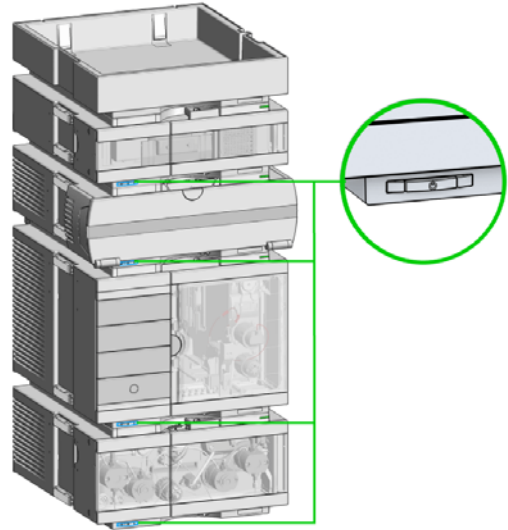

Power switch: Off

5

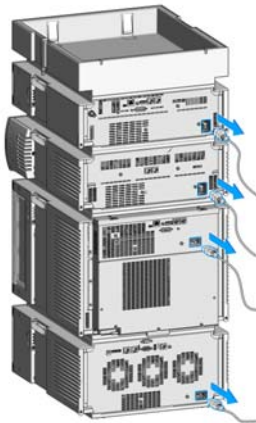



## Status Indicators

This procedure exemplarily shows an arbitrary LC stack configuration.

- 1 The module status indicator indicates one of six possible module conditions:

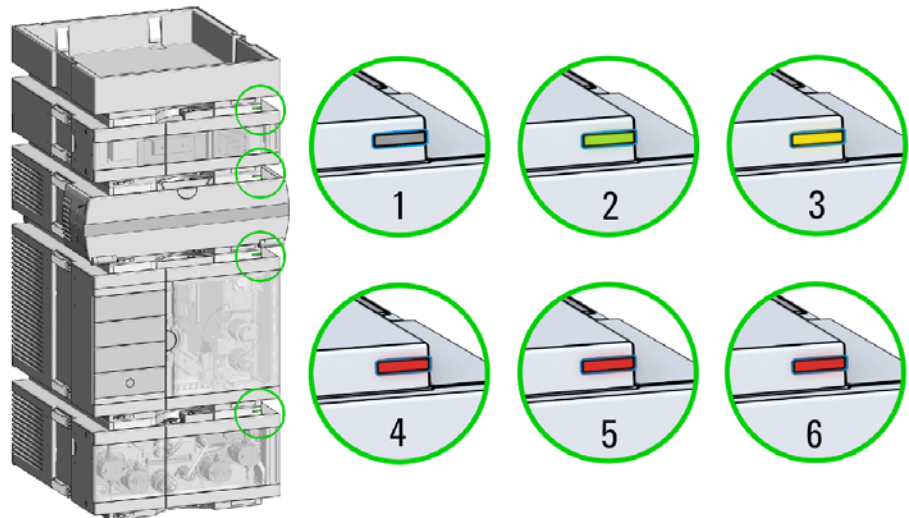

Status indicators

1. Idle
2. Run mode
3. Not-ready. Waiting for a specific pre-run condition to be reached or completed.
4. Error mode - interrupts the analysis and requires attention (for example a leak or defective internal components).
5. Resident mode (blinking) - for example during update of main firmware.
6. Bootloader mode (fast blinking). Try to re-boot the module or try a cold-start. Then try a firmware update.

## When to Use a Degasser?

### WARNING

#### *Unspecified Conditions*

**Operating the instrumentation under conditions other than its intended use might result in a potential safety hazard or might damage the instrumentation.**

- ✓ **Never operate your instrumentation under conditions other than those specified by the vendor.**

---

Pumps that mix the solvent on the low-pressure side need degassing and must be equipped with a degasser or alternative degassing systems (for example, helium). Isocratic pumps and high-pressure mixing pumps do not always require degassing. However for the following conditions the degasser is also recommended for an isocratic or a high pressure mixing pump:

- if your detector is used with maximum sensitivity in the low UV wavelength range,
- if your application requires optimum injection precision, or
- if your application requires highest retention time reproducibility (mandatory at flow rates below 0.5 mL/min),
- if your sample or detection is sensitive to dissolved oxygen in the mobile phase (degradation).

Generally a degasser should be used when negative effects due to dissolved gas in the mobile phase exceed the limits that are acceptable for the user. Negative effects that can be caused by dissolved gas are:

- Unstable flow due to unstable pumping conditions. This can result in a high ripple (unstable pressure at constant flow and with constant mobile phase composition) or high standard deviations of peak retention times and peak areas especially at low flow rates.
- Baseline noise on detectors that are sensitive to changes in the refractive index (for example, RI detector or UV detector in the low UV range, both at maximum sensitivity).
- Sample degradation.

## Using the Degasser

### When to Use a Degasser?

- Fluorescence quenching due to dissolved oxygen.
- Baseline drift in electrochemical detectors due to dissolved oxygen especially in reduction mode.

It is recommended to use the G7122A standalone degasser in applications using solvents with low boiling point (< 60 °C) as a component of the mobile phase; and when using the following solvents: hexane, tetrahydrofuran and any halogenated solvents, for example, chloroform, hexafluoroisopropanol.

## Solvent Information

Observe the following recommendations on the use of solvents.

- Follow the recommendations for avoiding the growth of algae, see the pump manuals.
- Small particles can permanently block capillaries and valves. Therefore, always filter solvents through 0.22 µm filters.
- Avoid or minimize the use of solvents that may corrode parts in the flow path. Consider specifications for the pH range given for different materials such as flow cells, valve materials etc. and recommendations in subsequent sections.

## Material Information

### Material in Flow Path

Following materials are used in the flow path of this module:

**Table 3** Material in flow path

Part	Material
Internal tubings	PTFE
Inlets	PEEK
Tubings	FEP
Fittings	ETFE

## General Information about Solvent/Material Compatibility

Materials in the flow path are carefully selected based on Agilent's experiences in developing highest quality instruments for HPLC analysis over several decades. These materials exhibit excellent robustness under typical HPLC conditions. For any special condition, please consult the material information section or contact Agilent.

### Disclaimer

Subsequent data was collected from external resources and is meant as a reference. Agilent cannot guarantee the correctness and completeness of such information. Data is based on compatibility libraries, which are not specific for estimating the long-term life time under specific but highly variable conditions of UHPLC systems, solvents, solvent mixtures and samples. Information can also not be generalized due to catalytic effects of impurities like metal ions, complexing agents, oxygen etc. Apart from pure chemical corrosion, other effects like electro corrosion, electrostatic charging (especially for non-conductive organic solvents), swelling of polymer parts etc. need to be considered. Most data available refers to room temperature (typically 20 – 25 °C, 68 – 77 °F). If corrosion is possible, it usually accelerates at higher temperatures. If in doubt, please consult technical literature on chemical compatibility of materials.

### PEEK

PEEK (Polyether-Ether Ketones) combines excellent properties regarding biocompatibility, chemical resistance, mechanical and thermal stability. PEEK is therefore the material of choice for UHPLC and biochemical instrumentation.

It is stable in the specified pH range (for the Bio-inert LC system: pH 1 – 13, see bio-inert module manuals for details), and inert to many common solvents.

There is still a number of known incompatibilities with chemicals such as chloroform, methylene chloride, THF, DMSO, strong acids (nitric acid > 10 %, sulfuric acid > 10 %, sulfonic acids, trichloroacetic acid), halogens or aqueous halogen solutions, phenol and derivatives (cresols, salicylic acid, and so on).

When used above room temperature, PEEK is sensitive to bases and various organic solvents, which can cause it to swell. Under such conditions, normal PEEK capillaries are very sensitive to high pressure. Therefore, Agilent uses stainless steel clad PEEK capillaries in bio-inert systems. The use of stainless steel clad PEEK capillaries keeps the flow path free of steel and ensures pressure stability to at least 600 bar. If in doubt, consult the available literature about the chemical compatibility of PEEK.

### Polyimide

Agilent uses semi-crystalline polyimide for rotor seals in valves and needle seats in autosamplers. One supplier of polyimide is DuPont, which brands polyimide as Vespel, which is also used by Agilent.

Polyimide is stable in a pH range between 1 and 10 and in most organic solvents. It is incompatible with concentrated mineral acids (e.g. sulphuric acid), glacial acetic acid, DMSO and THF. It is also degraded by nucleophilic substances like ammonia (e.g. ammonium salts in basic conditions) or acetates.

### Polyethylene (PE)

Agilent uses UHMW (ultra-high molecular weight)-PE/PTFE blends for yellow piston and wash seals, which are used in 1290 Infinity pumps, 1290 Infinity II pumps, the G7104C and for normal phase applications in 1260 Infinity pumps.

Polyethylene has a good stability for most common inorganic solvents including acids and bases in a pH range of 1 to 12.5. It is compatible with many organic solvents used in chromatographic systems like methanol, acetonitrile and isopropanol. It has limited stability with aliphatic, aromatic and halogenated hydrocarbons, THF, phenol and derivatives, concentrated acids and bases. For normal phase applications, the maximum pressure should be limited to 200 bar.

### Tantalum (Ta)

Tantalum is inert to most common HPLC solvents and almost all acids except fluoric acid and acids with free sulfur trioxide. It can be corroded by strong bases (e.g. hydroxide solutions > 10 %, diethylamine). It is not recommended for the use with fluoric acid and fluorides.

### Stainless Steel (SST)

Stainless steel is inert against many common solvents. It is stable in the presence of acids and bases in a pH range of 1 to 12.5. It can be corroded by acids below pH 2.3. It can also corrode in following solvents:

- Solutions of alkali halides, their respective acids (for example, lithium iodide, potassium chloride, and so on) and aqueous solutions of halogens.
- High concentrations of inorganic acids like nitric acid, sulfuric acid and organic solvents especially at higher temperatures (replace, if your chromatography method allows, by phosphoric acid or phosphate buffer which are less corrosive against stainless steel).

## Using the Degasser

### Solvent Information

- Halogenated solvents or mixtures which form radicals and/or acids, for example:  
$$2 \text{CHCl}_3 + \text{O}_2 \rightarrow 2 \text{COCl}_2 + 2 \text{HCl}$$

This reaction, in which stainless steel probably acts as a catalyst, occurs quickly with dried chloroform if the drying process removes the stabilizing alcohol.
- Chromatographic grade ethers, which can contain peroxides (for example, THF, dioxane, diisopropylether). Such ethers should be filtered through dry aluminium oxide which adsorbs the peroxides.
- Solutions of organic acids (acetic acid, formic acid, and so on) in organic solvents. For example, a 1 % solution of acetic acid in methanol will attack steel.
- Solutions containing strong complexing agents (for example, EDTA, ethylene diamine tetra-acetic acid).
- Mixtures of carbon tetrachloride with 2-propanol or THF.

#### Titanium (Ti)

Titanium is highly resistant to oxidizing acids (for example, nitric, perchloric and hypochlorous acid) over a wide range of concentrations and temperatures. This is due to a thin oxide layer on the surface, which is stabilized by oxidizing compounds. Non-oxidizing acids (for example, hydrochloric, sulfuric and phosphoric acid) can cause slight corrosion, which increases with acid concentration and temperature. For example, the corrosion rate with 3 % HCl (about pH 0.1) at room temperature is about 13  $\mu\text{m}/\text{year}$ . At room temperature, titanium is resistant to concentrations of about 5 % sulfuric acid (about pH 0.3). Addition of nitric acid to hydrochloric or sulfuric acids significantly reduces corrosion rates. Titanium is sensitive to acidic metal chlorides like  $\text{FeCl}_3$  or  $\text{CuCl}_2$ . Titanium is subject to corrosion in anhydrous methanol, which can be avoided by adding a small amount of water (about 3 %). Slight corrosion is possible with ammonia > 10 %.

#### Diamond-Like Carbon (DLC)

Diamond-Like Carbon is inert to almost all common acids, bases and solvents. There are no documented incompatibilities for HPLC applications.

Fused silica and Quartz ( $\text{SiO}_2$ )

Fused silica is used in Max Light Cartridges. Quartz is used for classical flow cell windows. It is inert against all common solvents and acids except hydrofluoric acid and acidic solvents containing fluorides. It is corroded by strong bases and should not be used above pH 12 at room temperature. The corrosion of flow cell windows can negatively affect measurement results. For a pH greater than 12, the use of flow cells with sapphire windows is recommended.

## Gold

Gold is inert to all common HPLC solvents, acids and bases within the specified pH range. It can be corroded by complexing cyanides and concentrated acids like aqua regia.

Zirconium Oxide ( $\text{ZrO}_2$ )

Zirconium Oxide is inert to almost all common acids, bases and solvents. There are no documented incompatibilities for HPLC applications.

## Platinum/Iridium

Platinum/Iridium is inert to almost all common acids, bases and solvents. There are no documented incompatibilities for HPLC applications.

## Fluorinated polymers (PTFE, PFA, FEP, FFKM, PVDF)

Fluorinated polymers like PTFE (polytetrafluorethylene), PFA (perfluoroalkoxy), and FEP (fluorinated ethylene propylene) are inert to almost all common acids, bases, and solvents. FFKM is perfluorinated rubber, which is also resistant to most chemicals. As an elastomer, it may swell in some organic solvents like halogenated hydrocarbons.

TFE/PDD copolymer tubings, which are used in all Agilent degassers except G1322A/G7122A, are not compatible with fluorinated solvents like Freon, Fluorinert, or Vertrel. They have limited life time in the presence of Hexafluoroisopropanol (HFIP). To ensure the longest possible life with HFIP, it is best to dedicate a particular chamber to this solvent, not to switch solvents, and not to let dry out the chamber. For optimizing the life of the pressure sensor, do not leave HFIP in the chamber when the unit is off.

The tubing of the leak sensor is made of PVDF (polyvinylidene fluoride), which is incompatible with the solvent DMF (dimethyl formamide).



Sapphire, Ruby and Al<sub>2</sub>O<sub>3</sub>-based ceramics

Sapphire, ruby and ceramics based on aluminum oxide Al<sub>2</sub>O<sub>3</sub> are inert to almost all common acids, bases and solvents. There are no documented incompatibilities for HPLC applications.

## Prevent Blocking of Solvent Filters

Contaminated solvents or algae growth in the solvent bottle will reduce the lifetime of the solvent filter and will influence the performance of the pump. This is especially true for aqueous solvents or phosphate buffers (pH 4 – 7). The following suggestions will prolong lifetime of the solvent filter and will maintain the performance of the pump.

- Use sterile, if possible amber solvent bottles to slow down algae growth.
- Filter solvents through filters or membranes that remove algae.
- Exchange solvents every two days or refilter.
- If the application permits add 0.0001 – 0.001 M sodium azide to the solvent.
- Place a layer of argon on top of your solvent.
- Avoid exposure of the solvent bottles to direct sunlight.

### Prevent Blocking of Solvent Filters

The solvent filters are on the low-pressure side of the pumping system. A blocked filter therefore does not affect the pressure readings of the pump. The pressure readings cannot be used to identify blocked filters. If the solvent cabinet is placed on top of the degasser the filter condition can be checked in the following way:

Remove the tubing at the inlet port of the degasser. If the filter is in good condition the solvent will freely drip out of the solvent tube (due to hydrostatic pressure). If the solvent filter is partly blocked no solvent or only very little solvent will drip out of the solvent tube.

### Cleaning the Solvent Filters

- Remove the blocked solvent filter from the bottle-head assembly and place it in a beaker with concentrated nitric acid (35 %) for one hour.
- Thoroughly flush the filter with bidistilled water (remove all nitric acid).
- Replace the filter.

**NOTE**

Never use the system without solvent filter installed.



## 4

# Troubleshooting and Diagnostics

Module Status Indicator 36

Hardware Symptoms 37

All Lamps are Off 37

If the Status Indicator is Red 37

If the Status Indicator is Yellow and the Vacuum Pump is not Running 38

Status Indicator becomes Red and Vacuum Pump was Running 39

Overview about the troubleshooting and diagnostic features.

## Module Status Indicator

### CAUTION

Red status LED indicates error

This indicates either an internal leak in the vacuum system or an electronic failure.

- ✓ To prevent any damage, switch off the vacuum degasser and remove the solvent bottles from the solvent cabinet to stop any gravity-caused flow of solvent into the vacuum chamber.
  - ✓ In case of an internal leak it is possible that solvent may enter the vacuum chamber and solvent may leak into the waste drain.
  - ✓ Apply troubleshooting information in “If the Status Indicator is Red” on page 37.
-

## Hardware Symptoms

In case of a problem with the vacuum system or the electronic control the vacuum degasser status lamp will be red. The vacuum degasser will generate an error output on the remote lines. This will shut down other system modules when connected via remote cable. The vacuum degasser itself is not able to generate any error messages in the Agilent 1260 Infinity system logbook. The following pages describe hardware symptoms which help you to isolate the cause of a hardware failure.

### All Lamps are Off

If all other modules in the system are on (power switch lamp is green) and are recognized by the connected user interface (module parameters can be set, module-specific screens appear, and so on), then do the following to determine the problem with the vacuum degasser:

- ✓ Ensure the power cable is connected to the degasser, and the power cable is connected to line power.
- ✓ Ensure the power switch on the front of the module is ON.
- ✓ Ensure the power fuses are OK.

The fuse holders are located on the rear panel of the vacuum degasser and are part of the power socket. Check the fuses (see ["Check and Change the Power Fuses"](#) on page 46), and change if necessary:

- ✓ If the previous steps did not solve the problem, contact your Agilent service representative.

### If the Status Indicator is Red

Sufficient vacuum is normally built up after the initial start-up and controlled by the pressure sensor.

If the vacuum cannot be reached, the vacuum degasser will switch to the error state. The error condition can be reset by turning the vacuum degasser off and on again.

## If the Status Indicator is Yellow and the Vacuum Pump is not Running

### NOTE

The status indicator is yellow during the startup phase of the degasser until the operating pressure is reached. This may take several minutes.

Please contact your Agilent service representative.

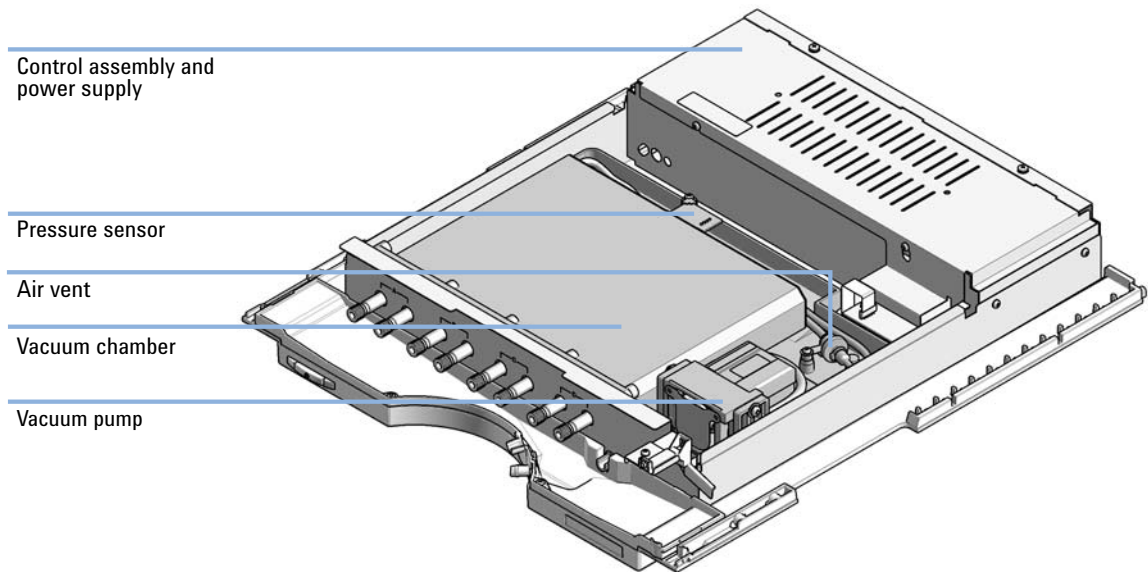

Figure 6 Overview of main assemblies

## **Status Indicator becomes Red and Vacuum Pump was Running**

Sufficient vacuum is normally built up after the initial start-up and controlled by the pressure sensor.

If the vacuum cannot be reached, the vacuum degasser will switch to the error state. The error condition can be reset by turning the vacuum degasser off and on again.

The following parts can be responsible for an insufficient vacuum:

- 1 Leaky tubing,
- 2 Leaky chambers,
- 3 Defective air vent,
- 4 Defective pump,
- 5 Defective electronics.



## 5

# Maintenance

Warnings and Cautions	41
Simple Repairs - Maintenance	43
Clean the Instrument	44
Assemble the Main Cover	45
Check and Change the Power Fuses	46

This chapter describes the maintenance of the module.



## Warnings and Cautions

### WARNING

#### *Open main cover*

The following procedures require opening the main cover of the vacuum degasser.

- ✓ To prevent personal injury, remove the power cable from the vacuum degasser before opening the cover.
  - ✓ Do not connect the power cable to the vacuum degasser while the covers are removed.
- 

### WARNING

#### Toxic, flammable and hazardous solvents, samples and reagents

The handling of solvents, samples and reagents can hold health and safety risks.

- ✓ When working with these substances observe appropriate safety procedures (for example by wearing goggles, safety gloves and protective clothing) as described in the material handling and safety data sheet supplied by the vendor, and follow good laboratory practice.
  - ✓ The volume of substances should be reduced to the minimum required for the analysis.
  - ✓ Do not operate the instrument in an explosive atmosphere.
- 

### CAUTION

Electronic boards and components are sensitive to electrostatic discharge (ESD).

ESD can damage electronic boards and components.

- ✓ Be sure to hold the board by the edges, and do not touch the electrical components. Always use ESD protection (for example, an ESD wrist strap) when handling electronic boards and components.
-

**CAUTION**

The sheet metal plates of the degasser are very thin.

Although they have been deburred, they are still quite sharp. You may cut your hands or fingers.

- ✓ Never slide your fingers along the edges of the enclosure.
- 

**WARNING**

*Instrument is partially energized when switched off*

The power supply still uses some power, even if the switch on the front panel is turned off.

- ✓ To disconnect the vacuum degasser from line, unplug the power cord.
-

## Simple Repairs - Maintenance

The degasser is designed for easy repair. The most frequent repairs such as exchanging power fuses can be performed by the user, and don't require opening the main cover of the degasser. These repairs are described in this chapter.

## Clean the Instrument

**WARNING**

Liquid dripping into the electronic compartment of your module can cause shock hazard and damage the module

- ✓ Do not use an excessively damp cloth during cleaning.
- ✓ Drain all solvent lines before opening any connections in the flow path.

---

The vacuum degasser case should be kept clean. Cleaning should be done with a soft cloth slightly dampened with water or a solution of water and a mild detergent. Do not use an excessively damp cloth that liquid can drip into the vacuum degasser.

## Assemble the Main Cover

**When** • If cover is broken.

Parts required	p/n	Description
	G7122-68713	Cover kit (includes base, top, left and right)

### CAUTION

#### Wrong assembly

In case you insert the left or right side in the opposite position, you may not be able to remove the side from the top part.

✓ Take care not to mix up left and right side.

### NOTE

The cover kit contains all parts, but it is not assembled.

**1** Place the top part on the bench and insert the left and right side into the top part.

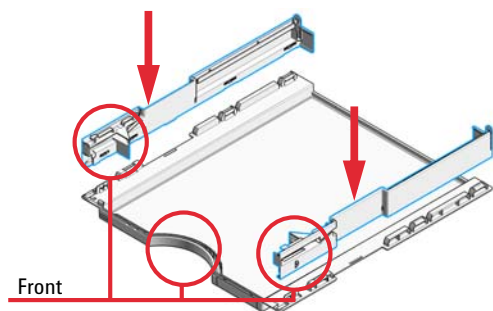

**2** Replace the cover.

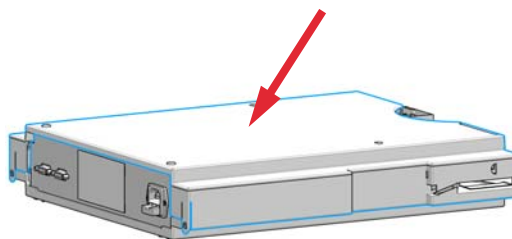

#### Next Steps:

- 3** Replace the degasser in the stack and reconnect the cables and capillaries.
- 4** Turn ON the degasser.

## Check and Change the Power Fuses

**When** • If the degasser appears dead

**Tools required** **Description**

Test meter  
(if available)

<b>Parts required</b>	<b>#</b>	<b>p/n</b>	<b>Description</b>
	1	2110-0458	Fuse: 250V, T 500 mA , compatible to all supported line voltages

### WARNING

#### Use of unsupplied cables

**Using cables not supplied by Agilent Technologies can lead to damage of the electronic components or personal injury.**

- ✓ **Never use cables other than the ones supplied by Agilent Technologies to ensure proper functionality and compliance with safety or EMC regulations.**

### NOTE

The module power supply has wide-ranging capability (see [Table 1](#) on page 19). It accepts any line voltage in these ranges. Consequently there is no voltage selector in the rear of the degasser. There are two externally accessible fuses, that protect the power supply. These fuses are identical for all accepted line voltages.

- 1** Switch OFF the power switch at the front of the instrument.
- 2** Remove the power cable from the power connector at the rear of the instrument.

- 3** Press down the clip of the fuse holder.

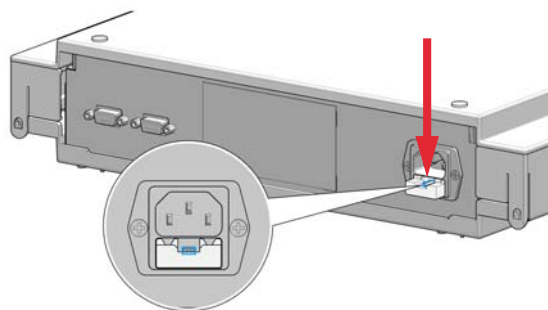

## Check and Change the Power Fuses

- 4 Pull the fuse holder out of the power socket.

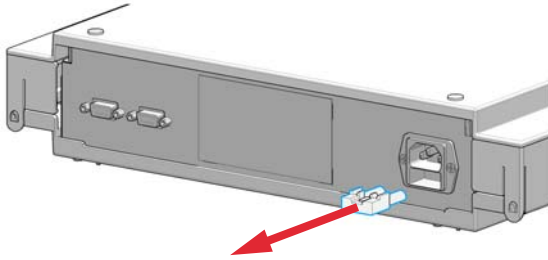

- 5 Remove the fuses from the fuse holders.

6 Ensure the fuse wires inside the fuses are not broken. If a test meter is available, check the resistance of each fuse. A good fuse shows a low resistance (approximately 0 Ohm).

7 If a fuse is defective (wire broken or high resistance), insert a new fuse.

- 8 Reinsert the fuse holders and the power cable.

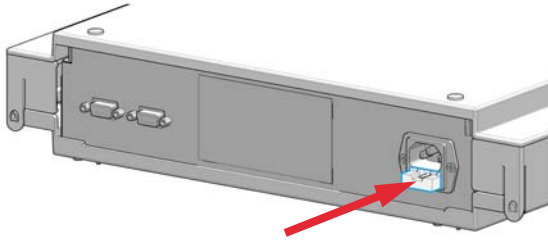

- 9 Switch ON the power switch.



## 6

# Parts for Maintenance and Repair

Cover Parts 49

Accessory Kit Contents 51

This chapter provides information on parts for maintenance.



## Cover Parts

The Cover kit (G7122-68713) contains the following parts:

Item	p/n	Description
1	5067-6219	Degasser Front Panel
2	5043-1414	Leak panel
3	5067-6582	Degasser Side Cover Kit
4	5043-1354	Name Plate 1290 Infinity 2
5	5067-5908	Top Cover Kit Infinity II
6	5043-0856	Leak Adapter
7	5043-0286	Base Cover Infinity II
	5041-8387	Tube clip not shown
	5041-8365	Blank plug for unused channels / not shown

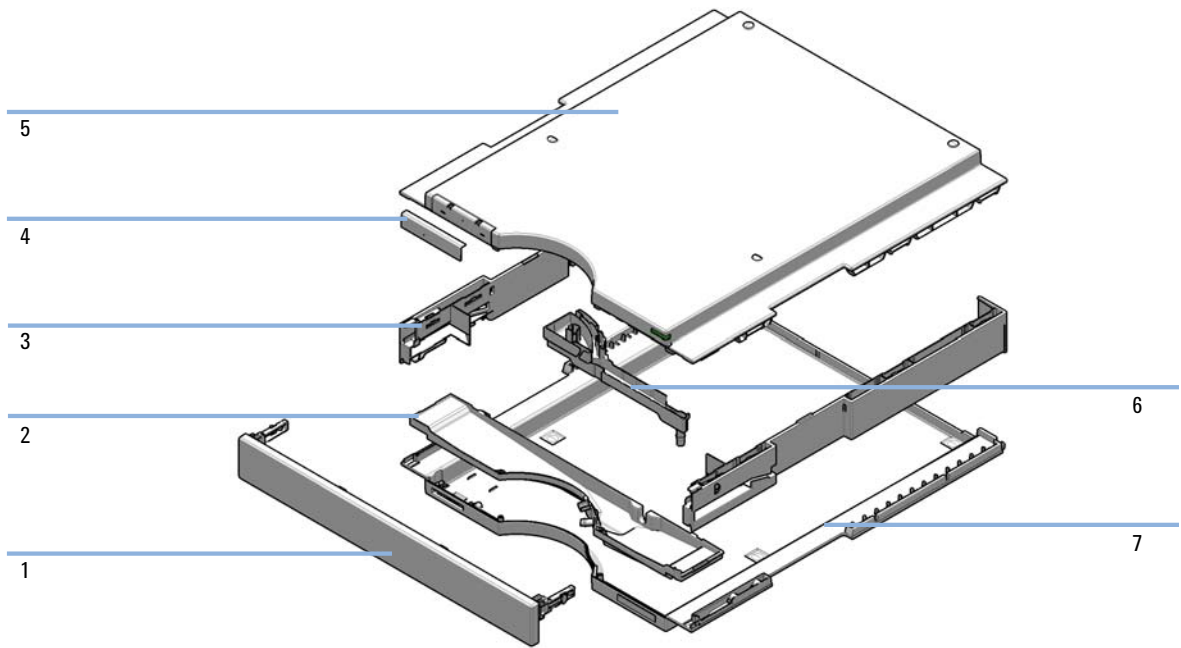

Figure 7 Cover Parts

## Accessory Kit Contents

### Accessory Kit (G7122-68705)

#	p/n	Description
8	0100-1700	FERRULE-AY-18IN
8	0100-1708	Nut 1/8 PPS
2	5041-8387	Tube clip
2	5043-1013	Tubing Clip
1	0100-1710	Mounting Tool for Tubing Connections
1	9301-1337	Syringe adapter
1	9301-0411	Syringe, Plastic
1	5974-0198	Wire Marker A
1	5974-0199	Wire Marker B
1	5974-0200	Wire Marker C
1	5974-0531	Wire Marker D
1	5974-0015	Wire Marker A1
1	5974-0016	Wire Marker A2
1	5974-0017	Wire Marker B1
1	5974-0018	Wire Marker B2
1	0890-1760	Tubing Flexible, 2 m
1	5188-8045	Remote Cable APG – ERI



# 7

## Identifying Cables

Cable Overview	53
Analog Cables	55
Remote Cables	57
CAN/LAN Cables	61
RS-232 Cables	62
USB Cables	63

This chapter provides information on cables used with the Agilent InfinityLab LC Series modules.

## Cable Overview

**NOTE**

Never use cables other than the ones supplied by Agilent Technologies to ensure proper functionality and compliance with safety or EMC regulations.

**Analog cables**

p/n	Description
35900-60750	Agilent 35900A A/D converter
01046-60105	Analog cable (BNC to general purpose, spade lugs)

**Remote cables**

p/n	Description
5188-8029	ERI to general purpose
5188-8044	Remote Cable ERI – ERI
5188-8045	Remote Cable APG – ERI
5188-8059	ERI-Extension-Cable 1.2 m
5061-3378	Remote Cable to 35900 A/D converter
01046-60201	Agilent module to general purpose
5188-8057	Fraction Collection ERI remote Y-cable

**CAN cables**

p/n	Description
5181-1516	CAN cable, Agilent module to module, 0.5 m
5181-1519	CAN cable, Agilent module to module, 1 m

**LAN cables**

p/n	Description
5023-0203	Cross-over network cable, shielded, 3 m (for point to point connection)
5023-0202	Twisted pair network cable, shielded, 7 m (for point to point connection)

**RS-232 cables  
(not for  
FUSION board)**

p/n	Description
RS232-61601	RS-232 cable, 2.5 m Instrument to PC, 9-to-9 pin (female). This cable has special pin-out, and is not compatible with connecting printers and plotters. It is also called "Null Modem Cable" with full handshaking where the wiring is made between pins 1-1, 2-3, 3-2, 4-6, 5-5, 6-4, 7-8, 8-7, 9-9.
5181-1561	RS-232 cable, 8 m

**USB cables**

p/n	Description
5188-8050	USB A M-USB Mini B 3 m (PC-Module)
5188-8049	USB A F-USB Mini B M OTG (Module to Flash Drive)

# Analog Cables

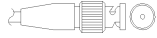

One end of these cables provides a BNC connector to be connected to Agilent modules. The other end depends on the instrument to which connection is being made.

Agilent Module to 35900 A/D converters

p/n 35900-60750	35900	Pin Agilent module	Signal Name
	1		Not connected
	2	Shield	Analog -
	3	Center	Analog +

**Identifying Cables**  
Analog Cables

Agilent Module to BNC Connector

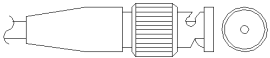
p/n 8120-1840	Pin BNC	Pin Agilent module	Signal Name
	Shield	Shield	Analog -
	Center	Center	Analog +

Agilent Module to General Purpose

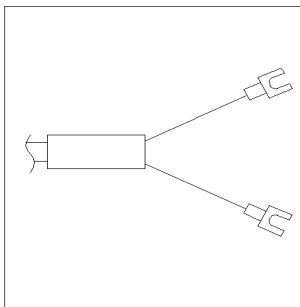
p/n 01046-60105	Pin	Pin Agilent module	Signal Name
	1		Not connected
	2	Black	Analog -
	3	Red	Analog +



## Remote Cables

ERI (Enhanced Remote Interface)

- 5188-8029 ERI to general purpose (D-Sub 15 pin male - open end)
- 5188-8044 ERI to ERI (D\_Sub 15 pin male - male)
- 5188-8059 ERI-Extension-Cable 1.2 m (D-Sub15 pin male / female)

p/n 5188-8029	pin	Color code	Enhanced Remote	Classic Remote	Active (TTL)
<p><b>D-Sub female 15way</b> user's view to connector</p>	1	white	I01	START REQUEST	Low
	2	brown	I02	STOP	Low
	3	green	I03	READY	High
	4	yellow	I04	POWER ON	High
	5	grey	I05	NOT USED	
	6	pink	I06	SHUT DOWN	Low
	7	blue	I07	START	Low
	8	red	I08	PREPARE	Low
	9	black	1wire DATA		
	10	violet	DGND		
	11	grey-pink	+5V ERI out		
	12	red-blue	PGND		
	13	white-green	PGND		
	14	brown-green	+24V ERI out		
	15	white-yellow	+24V ERI out		
	NC	yellow-brown			

## Identifying Cables

### Remote Cables

- 5188-8045 ERI to APG (Connector D\_Subminiature 15 pin (ERI), Connector D\_Subminiature 9 pin (APG))

p/n 5188-8045	Pin (ERI)	Signal	Pin (APG)	Active (TTL)
	10	GND	1	
	1	Start Request	9	Low
	2	Stop	8	Low
	3	Ready	7	High
	5	Power on	6	High
	4	Future	5	
	6	Shut Down	4	Low
	7	Start	3	Low
	8	Prepare	2	Low
	Ground	Cable Shielding	NC	

## Identifying Cables

### Remote Cables

- 5188-8057 ERI to APG and RJ45 (Connector D\_Subminiature 15 pin (ERI), Connector D\_Subminiature 9 pin (APG), Connector plug Cat5e (RJ45))

**Table 4** 5188-8057 ERI to APG and RJ45

p/n 5188-8057	Pin (ERI)	Signal	Pin (APG)	Active (TTL)	Pin (RJ45)
	10	GND	1		5
	1	Start Request	9	High	
	2	Stop	8	High	
	3	Ready	7	High	
	4	Fraction Trigger	5	High	4
	5	Power on	6	High	
	6	Shut Down	4	High	
	7	Start	3	High	
	8	Prepare	2	High	
	Ground	Cable Shielding	NC		



One end of these cables provides a Agilent Technologies APG (Analytical Products Group) remote connector to be connected to Agilent modules. The other end depends on the instrument to be connected to.

## Identifying Cables

### Remote Cables

#### Agilent Module to Agilent 35900 A/D Converters

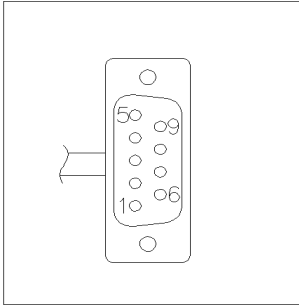
p/n 5061-3378	Pin 35900 A/D	Pin Agilent module	Signal Name	Active (TTL)
	1 - White	1 - White	Digital ground	
	2 - Brown	2 - Brown	Prepare run	Low
	3 - Gray	3 - Gray	Start	Low
	4 - Blue	4 - Blue	Shut down	Low
	5 - Pink	5 - Pink	Not connected	
	6 - Yellow	6 - Yellow	Power on	High
	7 - Red	7 - Red	Ready	High
	8 - Green	8 - Green	Stop	Low
	9 - Black	9 - Black	Start request	Low

#### Agilent Module to General Purpose

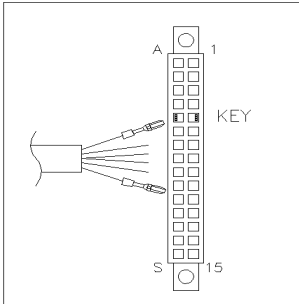
p/n 01046-60201	Wire Color	Pin Agilent module	Signal Name	Active (TTL)
	White	1	Digital ground	
	Brown	2	Prepare run	Low
	Gray	3	Start	Low
	Blue	4	Shut down	Low
	Pink	5	Not connected	
	Yellow	6	Power on	High
	Red	7	Ready	High
	Green	8	Stop	Low
	Black	9	Start request	Low

## CAN/LAN Cables

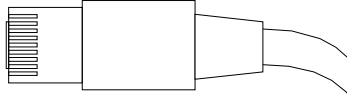

Both ends of this cable provide a modular plug to be connected to Agilent modules CAN or LAN connectors.

### CAN Cables

p/n	Description
5181-1516	CAN cable, Agilent module to module, 0.5 m
5181-1519	CAN cable, Agilent module to module, 1 m

### LAN Cables

p/n	Description
5023-0203	Cross-over network cable, shielded, 3 m (for point to point connection)
5023-0202	Twisted pair network cable, shielded, 7 m (for point to point connection)

## RS-232 Cables

<b>p/n</b>	<b>Description</b>
RS232-61601	RS-232 cable, 2.5 m Instrument to PC, 9-to-9 pin (female). This cable has special pin-out, and is not compatible with connecting printers and plotters. It is also called "Null Modem Cable" with full handshaking where the wiring is made between pins 1-1, 2-3, 3-2, 4-6, 5-5, 6-4, 7-8, 8-7, 9-9.
5181-1561	RS-232 cable, 8 m

## USB Cables

To connect a USB Flash Drive use a USB OTG cable with Mini-B plug and A socket.

p/n	Description
5188-8050	USB A M-USB Mini B 3 m (PC-Module)
5188-8049	USB A F-USB Mini B M OTG (Module to Flash Drive)



## 8 Hardware Information

Electrical Connections	65
Rear View of the Module	65
Information on Instrument Serial Number	66
Interfaces	67
Instrument Layout	69

This chapter describes the detector in more detail on hardware and electronics.



## Electrical Connections

- The CAN bus is a serial bus with high-speed data transfer. The two connectors for the CAN bus are used for internal module data transfer and synchronization.
- The ERI/REMOTE connector may be used in combination with other analytical instruments from Agilent Technologies if you want to use features such as start, stop, common shutdown, prepare, and so on.
- With the appropriate software, the LAN connector may be used to control the module from a computer through a LAN connection. This connector is activated and can be configured with the configuration switch.
- With the appropriate software, the USB connector may be used to control the module from a computer through a USB connection.
- The power input socket accepts a line voltage of 100 – 240 VAC  $\pm$  10 % with a line frequency of 50 or 60 Hz. Maximum power consumption varies by module. There is no voltage selector on your module because the power supply has wide-ranging capability. There are no externally accessible fuses because automatic electronic fuses are implemented in the power supply.

**NOTE**

Never use cables other than the ones supplied by Agilent Technologies to ensure proper functionality and compliance with safety or EMC regulations.

## Rear View of the Module

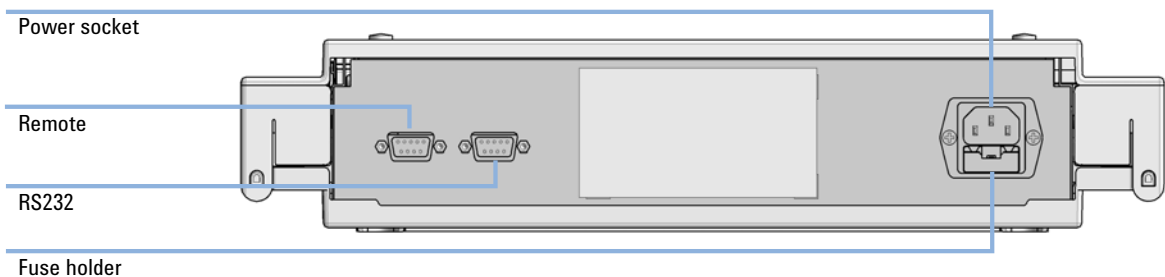

Figure 8 Rear view of the degasser

## Information on Instrument Serial Number

The serial number information on the instrument labels provide the following information:

CCXZZ00000	Format
CC	Country of manufacturing <ul style="list-style-type: none"><li>• DE = Germany</li><li>• JP = Japan</li><li>• CN = China</li></ul>
X	Alphabetic character A-Z (used by manufacturing)
ZZ	Alpha-numeric code 0-9, A-Z, where each combination unambiguously denotes a module (there can be more than one code for the same module)
00000	Serial number

## Interfaces

The Agilent InfinityLab LC Series modules provide the following interfaces:

**Table 5** Agilent InfinityLab LC Series Interfaces

Module	CAN	USB	LAN (on-board)	RS-232	Analog	APG (A) / ERI (E)	Special
<b>Pumps</b>							
G7104A/C	2	No	Yes	Yes	1	A	
G7110B	2	Yes	Yes	No	No	E	
G7111A/B, G5654A	2	Yes	Yes	No	No	E	
G7112B	2	Yes	Yes	No	No	E	
G7120A	2	No	Yes	Yes	1	A	
G7161A/B	2	Yes	Yes	No	No	E	
<b>Samplers</b>							
G7129A/B/C	2	Yes	Yes	No	No	E	
G7167B/C, G5667A	2	Yes	Yes	No	No	E	
G7157A	2	Yes	Yes	No	No	E	
<b>Detectors</b>							
G7114A/B	2	Yes	Yes	No	1	E	
G7115A	2	Yes	Yes	No	1	E	
G7117A/B/C	2	Yes	Yes	No	1	E	
G7121A/B	2	Yes	Yes	No	1	E	
G7162A/B	2	Yes	Yes	No	1	E	
G7165A	2	Yes	Yes	No	1	E	

Table 5 Agilent InfinityLab LC Series Interfaces

Module	CAN	USB	LAN (on-board)	RS-232	Analog	APG (A) / ERI (E)	Special
<b>Fraction Collectors</b>							
G7158B	2	Yes	Yes	No	No	E	
G7159B	2	Yes	Yes	No	No	E	
G7166A	2	No	No	No	No	No	Requires a host module with on-board LAN with minimum FW B.06.40 or C.06.40, or with additional G1369C LAN Card
G1364E/F, G5664B	2	Yes	Yes	No	No	E	THERMOSTAT for G1330B
<b>Others</b>							
G7116A/B	2	No	No	No	No	No	Requires a HOST module via CAN
G7122A	No	No	No	Yes	No	A	
G7170B	2	No	No	No	No	No	Requires a host module with on-board LAN with minimum FW B.06.40 or C.06.40, or with additional G1369C LAN Card

**NOTE**

The detector (DAD/MWD/FLD/VWD/RID) is the preferred access point for control via LAN. The inter-module communication is done via CAN.

- CAN connectors as interface to other modules
- LAN connector as interface to the control software
- RS-232C as interface to a computer
- USB (Universal Series Bus) as interface to a computer
- REMOTE connector as interface to other Agilent products
- Analog output connector(s) for signal output

## Instrument Layout

The industrial design of the module incorporates several innovative features. It uses Agilent's E-PAC concept for the packaging of electronics and mechanical assemblies. This concept is based upon the use of expanded polypropylene (EPP) layers of foam plastic spacers in which the mechanical and electronic boards components of the module are placed. This pack is then housed in a metal inner cabinet which is enclosed by a plastic external cabinet. The advantages of this packaging technology are:

- virtual elimination of fixing screws, bolts or ties, reducing the number of components and increasing the speed of assembly/disassembly,
- the plastic layers have air channels molded into them so that cooling air can be guided exactly to the required locations,
- the plastic layers help cushion the electronic and mechanical parts from physical shock, and
- the metal inner cabinet shields the internal electronics from electromagnetic interference and also helps to reduce or eliminate radio frequency emissions from the instrument itself.

# 9

## Appendix

General Safety Information	71
General Safety Information	71
Safety Standards	71
General	71
Before Applying Power	72
Ground the Instrument	72
Do Not Operate in an Explosive Atmosphere	73
Do Not Remove the Instrument Cover	73
Do Not Modify the Instrument	73
In Case of Damage	73
Solvents	74
Safety Symbols	75
Waste Electrical and Electronic Equipment (WEEE) Directive	77
Radio Interference	78
Sound Emission	79
Agilent Technologies on Internet	80

This chapter provides additional information on safety, legal and web.

## General Safety Information

### General Safety Information

The following general safety precautions must be observed during all phases of operation, service, and repair of this instrument. Failure to comply with these precautions or with specific warnings elsewhere in this manual violates safety standards of design, manufacture, and intended use of the instrument. Agilent Technologies assumes no liability for the customer's failure to comply with these requirements.

#### **WARNING**

**Ensure the proper usage of the equipment.**

**The protection provided by the equipment may be impaired.**

- ✓ **The operator of this instrument is advised to use the equipment in a manner as specified in this manual.**

### Safety Standards

This is a Safety Class I instrument (provided with terminal for protective earthing) and has been manufactured and tested according to international safety standards.

### General

Do not use this product in any manner not specified by the manufacturer. The protective features of this product may be impaired if it is used in a manner not specified in the operation instructions.

## Before Applying Power

**WARNING**

Wrong voltage range, frequency or cabling  
Personal injury or damage to the instrument

- ✓ Verify that the voltage range and frequency of your power distribution matches to the power specification of the individual instrument.
- ✓ Never use cables other than the ones supplied by Agilent Technologies to ensure proper functionality and compliance with safety or EMC regulations.
- ✓ Make all connections to the unit before applying power.

**NOTE**

Note the instrument's external markings described under "Safety Symbols" on page 75.

## Ground the Instrument

**WARNING**

Missing electrical ground  
Electrical shock

- ✓ If your product is provided with a grounding type power plug, the instrument chassis and cover must be connected to an electrical ground to minimize shock hazard.
- ✓ The ground pin must be firmly connected to an electrical ground (safety ground) terminal at the power outlet. Any interruption of the protective (grounding) conductor or disconnection of the protective earth terminal will cause a potential shock hazard that could result in personal injury.



## Do Not Operate in an Explosive Atmosphere

**WARNING**

Presence of flammable gases or fumes

Explosion hazard

- ✓ Do not operate the instrument in the presence of flammable gases or fumes.
- 

## Do Not Remove the Instrument Cover

**WARNING**

Instrument covers removed

Electrical shock

- ✓ Do Not Remove the Instrument Cover
  - ✓ Only Agilent authorized personnel are allowed to remove instrument covers. Always disconnect the power cables and any external circuits before removing the instrument cover.
- 

## Do Not Modify the Instrument

Do not install substitute parts or perform any unauthorized modification to the product. Return the product to an Agilent Sales and Service Office for service and repair to ensure that safety features are maintained.

## In Case of Damage

**WARNING**

Damage to the module

Personal injury (for example electrical shock, intoxication)

- ✓ Instruments that appear damaged or defective should be made inoperative and secured against unintended operation until they can be repaired by qualified service personnel.
-

## Solvents

**WARNING**

Toxic, flammable and hazardous solvents, samples and reagents

The handling of solvents, samples and reagents can hold health and safety risks.

- ✓ When working with these substances observe appropriate safety procedures (for example by wearing goggles, safety gloves and protective clothing) as described in the material handling and safety data sheet supplied by the vendor, and follow good laboratory practice.
- ✓ Do not use solvents with an auto-ignition temperature below 200 °C (392 °F). Do not use solvents with a boiling point below 56 °C (133 °F).
- ✓ Avoid high vapor concentrations. Keep the solvent temperature at least 40 K below the boiling point of the solvent used. This includes the solvent temperature in the sample compartment. For the solvents methanol and ethanol keep the solvent temperature at least 25 K below the boiling point.
- ✓ Do not operate the instrument in an explosive atmosphere.
- ✓ Do not use solvents of ignition Class IIC according IEC 60079-20-1 (for example, carbon disulfide).
- ✓ Reduce the volume of substances to the minimum required for the analysis.
- ✓ Never exceed the maximum permissible volume of solvents (8 L) in the solvent cabinet. Do not use bottles that exceed the maximum permissible volume as specified in the usage guideline for solvent cabinet.
- ✓ Ground the waste container.
- ✓ Regularly check the filling level of the waste container. The residual free volume in the waste container must be large enough to collect the waste liquid.
- ✓ To achieve maximal safety, regularly check the tubing for correct installation.

---

**NOTE**

For details, see the usage guideline for the solvent cabinet. A printed copy of the guideline has been shipped with the solvent cabinet, electronic copies are available in the Agilent Information Center or via the Internet.

---

## Safety Symbols

Table 6 Symbols













	The apparatus is marked with this symbol when the user shall refer to the instruction manual in order to protect risk of harm to the operator and to protect the apparatus against damage.
	Indicates dangerous voltages.
	Indicates a protected ground terminal.
	The apparatus is marked with this symbol when hot surfaces are available and the user should not touch it when heated up.
	Sample Cooler unit is designed as vapor-compression refrigeration system. Contains fluorinated greenhouse gas (refrigerant) according to the Kyoto protocol. For specifications of refrigerant, charge capacity, carbon dioxide equivalent (CDE), and global warming potential (GWP) see instrument label.
	Flammable Material For Sample Thermostat which uses flammable refrigerant consult Agilent Information Center / User Manual before attempting to install or service this equipment. All safety precautions must be followed.
	Confirms that a manufactured product complies with all applicable European Community directives. The European Declaration of Conformity is available at: <a href="http://regulations.corporate.agilent.com/DoC/search.htm">http://regulations.corporate.agilent.com/DoC/search.htm</a>
	Manufacturing date.
	Power symbol indicates On/Off. The apparatus is not completely disconnected from the mains supply when the power switch is in the Off position
	Pacemaker Magnets could affect the functioning of pacemakers and implanted heart defibrillators. A pacemaker could switch into test mode and cause illness. A heart defibrillator may stop working. If you wear these devices keep at least 55 mm distance to magnets. Warn others who wear these devices from getting too close to magnets.

Table 6 Symbols

	<p>Magnetic field</p> <p>Magnets produce a far-reaching, strong magnetic field. They could damage TVs and laptops, computer hard drives, credit and ATM cards, data storage media, mechanical watches, hearing aids and speakers. Keep magnets at least 25 mm away from devices and objects that could be damaged by strong magnetic fields.</p>
	<p>Indicates a pinching or crushing hazard</p>
	<p>Indicates a piercing or cutting hazard.</p>

## WARNING

### A WARNING

alerts you to situations that could cause physical injury or death.

- ✓ Do not proceed beyond a warning until you have fully understood and met the indicated conditions.

## CAUTION

### A CAUTION

alerts you to situations that could cause loss of data, or damage of equipment.

- ✓ Do not proceed beyond a caution until you have fully understood and met the indicated conditions.

## Waste Electrical and Electronic Equipment (WEEE) Directive

This product complies with the European WEEE Directive marking requirements. The affixed label indicates that you must not discard this electrical/electronic product in domestic household waste.

**NOTE**

Do not dispose of in domestic household waste

To return unwanted products, contact your local Agilent office, or see <http://www.agilent.com> for more information.

## Radio Interference

Cables supplied by Agilent Technologies are screened to provide optimized protection against radio interference. All cables are in compliance with safety or EMC regulations.

### Test and Measurement

If test and measurement equipment is operated with unscreened cables, or used for measurements on open set-ups, the user has to assure that under operating conditions the radio interference limits are still met within the premises.

## Sound Emission

### Manufacturer's Declaration

This statement is provided to comply with the requirements of the German Sound Emission Directive of 18 January 1991.

This product has a sound pressure emission (at the operator position) < 70 dB.

- Sound Pressure  $L_p < 70$  dB (A)
- At Operator Position
- Normal Operation
- According to ISO 7779:1988/EN 27779/1991 (Type Test)

## Agilent Technologies on Internet

For the latest information on products and services visit our worldwide web site on the Internet at:

<http://www.agilent.com>



## In This Book

This manual contains service information about the Agilent 1260 Infinity II Degasser. The manual describes the following:

- introduction,
- site requirements and specifications,
- using the degasser,
- troubleshooting and diagnostics,
- maintenance,
- parts for maintenance,
- identifying cables,
- appendix.

[www.agilent.com](http://www.agilent.com)

© Agilent Technologies Inc. 2016-2020

Published in Germany  
03/2020



Part No: G7122-90000 Rev. C  
Document No: SD-29000216

